

Customer :
 Project Name :
 Project No. :
 Revision No. :

SPECIFICATION for INDUCTION MOTOR



0		For Bidding			
No.	DATE	DESCRIPTION	PREPARED BY	CHECKED BY	APPROVED BY



AC INDUCTION MOTOR DATA SHEET

Catalog No.	HES1.5-18-145TCRD	Item No.		Rev. No.	[]	
Project Name		Project No.		Quantity	sets	
GENERAL SPECIFICATION			PERFORMANCE DATA			
Frame Size	145TC	Rated Output	1.1 kW 1.5 HP			
Type	PJP	Number of Poles	4			
Enclosure(Protection)	Totally Enclosed / IP55	Rotor Type	Squirrel Cage			
Method of Cooling	IC411(FC)	Starting Method*	D.O.L			
Rated Frequency	60 Hz	Rated Voltage	575 V	460 V	230 V	
Number of Phases	3	Current	Full Load	1.77 A	2.22 A	
Insulation Class	F		Locked-rotor**	900 %	900 %	900 %
Temp. Rise at full load (by resistance method)		Efficiency				
at 1.0 S.F	80 deg. C	50% Load		83.5 %		
Motor Location	<input type="checkbox"/> Indoor <input type="checkbox"/> Outdoor	75% Load		85.5 %		
Altitude	Less than 1,000 meter	100% Load		86.5 %		
Relative Humidity	Less than 80 %	Power Factor(p.u)				
Ambient Temp.	40 deg. C (Max.)	50% Load		0.570		
Duty Type	Continuous (S1)	75% Load		0.670		
Service Factor	1.15	100% Load		0.720		
Mounting	B5	Speed at Full Load		1750 r.p.m		
Bearing	Type	Anti-Friction				
	DE/N-DE	6205ZZC3 / 6204ZZC3				
	Lubricant	Grease(Polyrex-EM)				
External Thrust	Not applicable					
Coupling Method	<input checked="" type="checkbox"/> Direct <input type="checkbox"/> V-belt	Torque				
Shaft Extension	Single	Full Load		4.4 lb.ft		
Terminal Box	Main	Locked-rotor**		260 %		
	Aux.	Breakdown**		290 %		
Location	Refer to Outline Drawing	Moment of Inertia (J)				
Application		Load(Max.)		11.865 lb.ft2		
Area classification	Hazardous	Motor		0.076 lb.ft2		
Type of Ex-Protection	Class I&II, Division 2	Sound Pressure Level (No-load & mean value at 1m from motor)				
Applicable Standard	NEMA MG1, CSA C390	56 dB(A)				
ACCESSORIES			SUBMITTAL DRAWING			
			Outline Dimension Drawing		Motor Weight(Approx.)	
			B5		LM-T2145C5PLV23	60 lb.
			REMARK			
SPARE PARTS			1. Premium efficiency according to NEMA MG1			
			2. Inverter Duty @ 1.0 Service Factor & F Temperature rise			
			- 10:1 VT (20:1 VT at 50% load)			
			- 10:1 CT			
			- CHP up to 1.5 times base speed, NEMA MG1 Part31			
			3. CSA Certification			
			- Class I, Division 2, Group A, B, C & D			
			- Class II, Division 2 Group E, F & G (Group E : up to 320Fr.)			
			4. Service Factor 1.15 and Temperature rise B are applicable under the condition of sine wave power.			
			5. Service Factor 1.25 is applicable to motors of 100HP or less with temperature rise F & Non-Hazardous.			
		Date	DSND	CHKD	CHKD	APPD
		2024-09-10	S.H. Lee	I.K. Kim	R.G. Kim	S.W. Kim

[Note] Others not mentioned in this data sheet shall be in accordance with maker standard.
 Above technical data are only design values and shall be guaranteed with tolerance of applicable standard.
 Inspection and performance test shall be done according to maker standard, if not mentioned.
 * In case of Inverter-Fed Motor, performance data is based on sine wave tests. It may be different from test data of Inverter combined motor.
 ** Data is based on rated voltage & frequency and is expressed as a percentage of full-load value.

	1	2	3	4			
	REV	DATE	CONTENTS	REVD BY	CHKD BY	CHKD BY	APPD BY

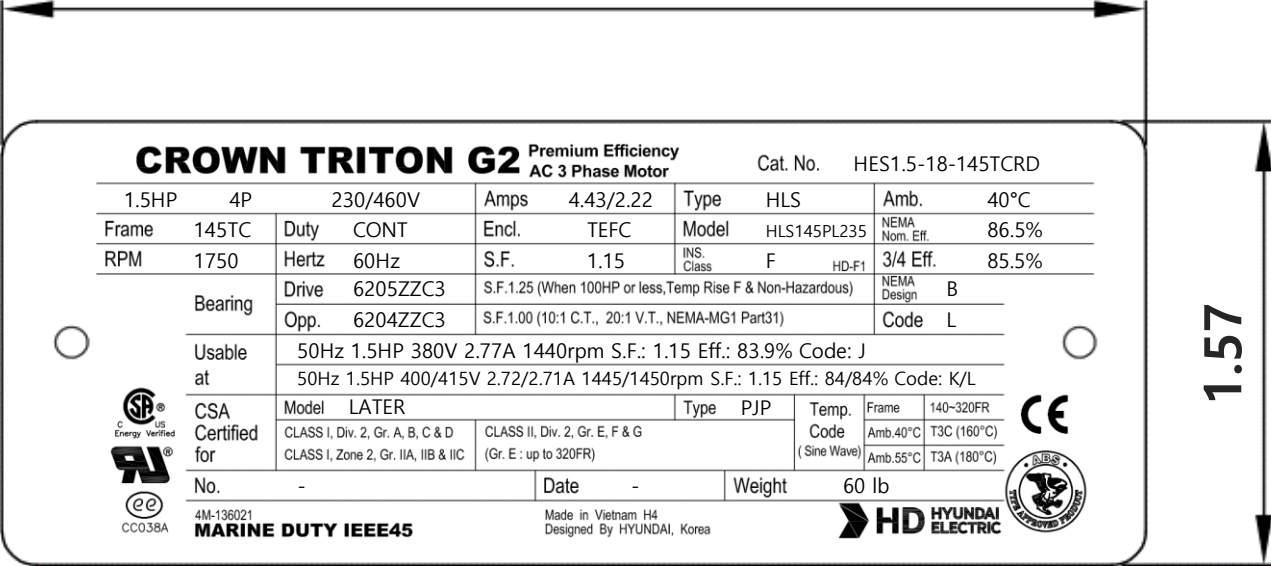

3.94



1.57



CROWN TRITON G2 Premium Efficiency AC 3 Phase Motor Cat. No. HES1.5-18-145TCRD

1.5HP	4P	230/460V	Amps	4.43/2.22	Type	HLS	Amb.	40°C
Frame	145TC	Duty	CONT	Encl.	TEFC	Model	HLS145PL235	NEMA Nom. Eff. 86.5%
RPM	1750	Hertz	60Hz	S.F.	1.15	INS Class	F HD-F1	3/4 Eff. 85.5%
Bearing	Drive	6205ZZC3	S.F.1.25 (When 100HP or less, Temp Rise F & Non-Hazardous)				NEMA Design	B
	Opp.	6204ZZC3	S.F.1.00 (10:1 C.T., 20:1 V.T., NEMA-MG1 Part31)				Code	L
Usable at	50Hz 1.5HP 380V 2.77A 1440rpm S.F.: 1.15 Eff.: 83.9% Code: J							
	50Hz 1.5HP 400/415V 2.72/2.71A 1445/1450rpm S.F.: 1.15 Eff.: 84/84% Code: K/L							
CSA Certified for	Model	LATER	Type	PJP	Temp. Code	Frame	140-320FR	
	CLASS I, Div. 2, Gr. A, B, C & D CLASS I, Zone 2, Gr. IIA, IIB & IIC		CLASS II, Div. 2, Gr. E, F & G (Gr. E: up to 320FR)		(Sine Wave)	Amb.40°C T3C (160°C) Amb.55°C T3A (180°C)		
No.	-		Date	-		Weight	60 lb	

4M-136021
MARINE DUTY IEEE45

Made in Vietnam H4
Designed By HYUNDAI, Korea





APPD BY	S.Y.KIM	UNIT	INCH	SUBJECT	CSA Class I, Division2 Severe Duty (HES, 143-215)	DWG SIZE
CHKD BY	I.K.KIM	SCALE	NONE	TITLE	NAMEPLATE DRAWING	A4 (1:1)
CHKD BY	R.G.KIM	PROJEC'N	3rd Angle			
DSND BY	S.H.LEE	DATE	2024.06.07			
				REF. NO	4M-136021	Sheet No. of
				DWG NO	NP-HES1.5-18-145TCRD	Revision No. 0

Type :	PJP
Full Load Torque :	4.4 lb.ft
Load moment of Inertia (J) :	11.865 lb.ft2
Motor moment of Inertia (J) :	0.076 lb.ft2

1.1kW 1.5HP	4 P	60 Hz
Speed at Full Load :		1750 RPM
Rated Voltage	575V	460V 230V
Full Load Current	1.8A	2.2A 4.4A

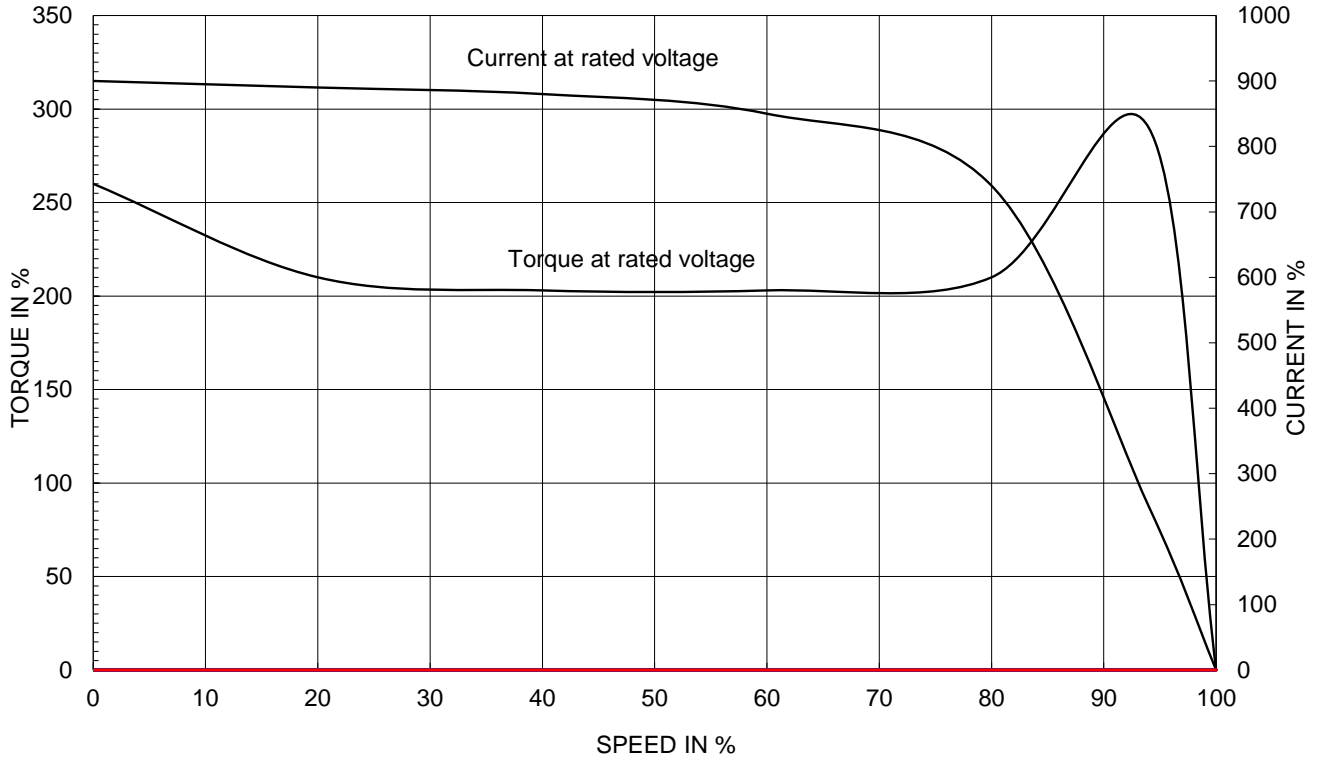
SPEED VS TORQUE & CURRENT CURVE



OUTPUT VS EFF., P.F & CURRENT CURVE

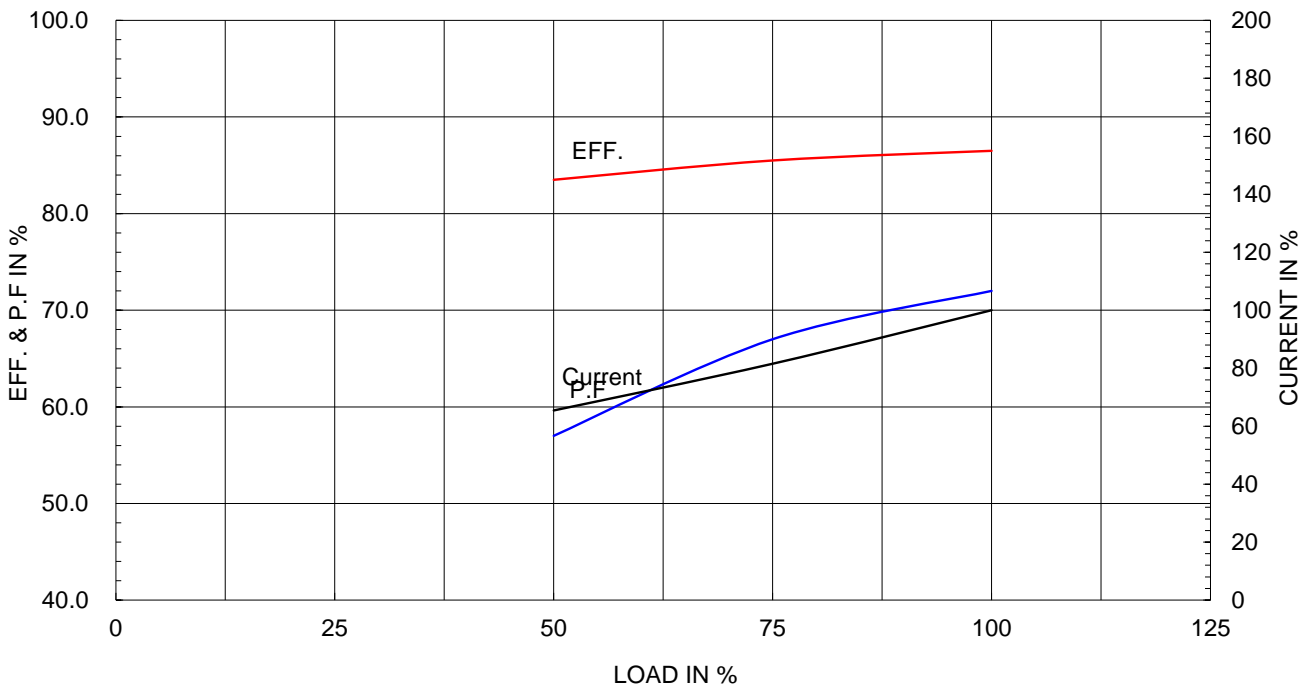

본 도면은 HD현대일렉트릭(주) 재산이며 허가없이 복사할 수 없음 (취급유의)

THIS DRAWING IS PROPRIETARY TO HYUNDAI ELECTRIC. NO PART OF THIS DRAWING MAYBE REPRODUCED WITHOUT THE PERMISSION OF HYUNDAI ELECTRIC.

▽	50S	REV	DATE	CONTENTS	REVD BY	CHKD BY	CHKD BY	APPD BY
▽▽	12.5S							
▽▽▽	3.2S							
▽▽▽▽	0.4S							

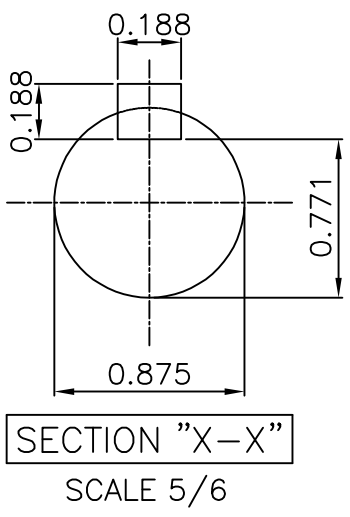
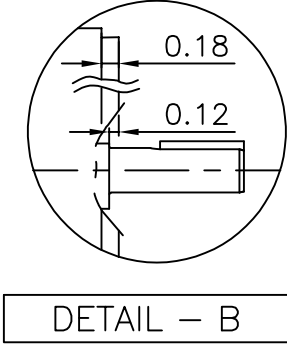
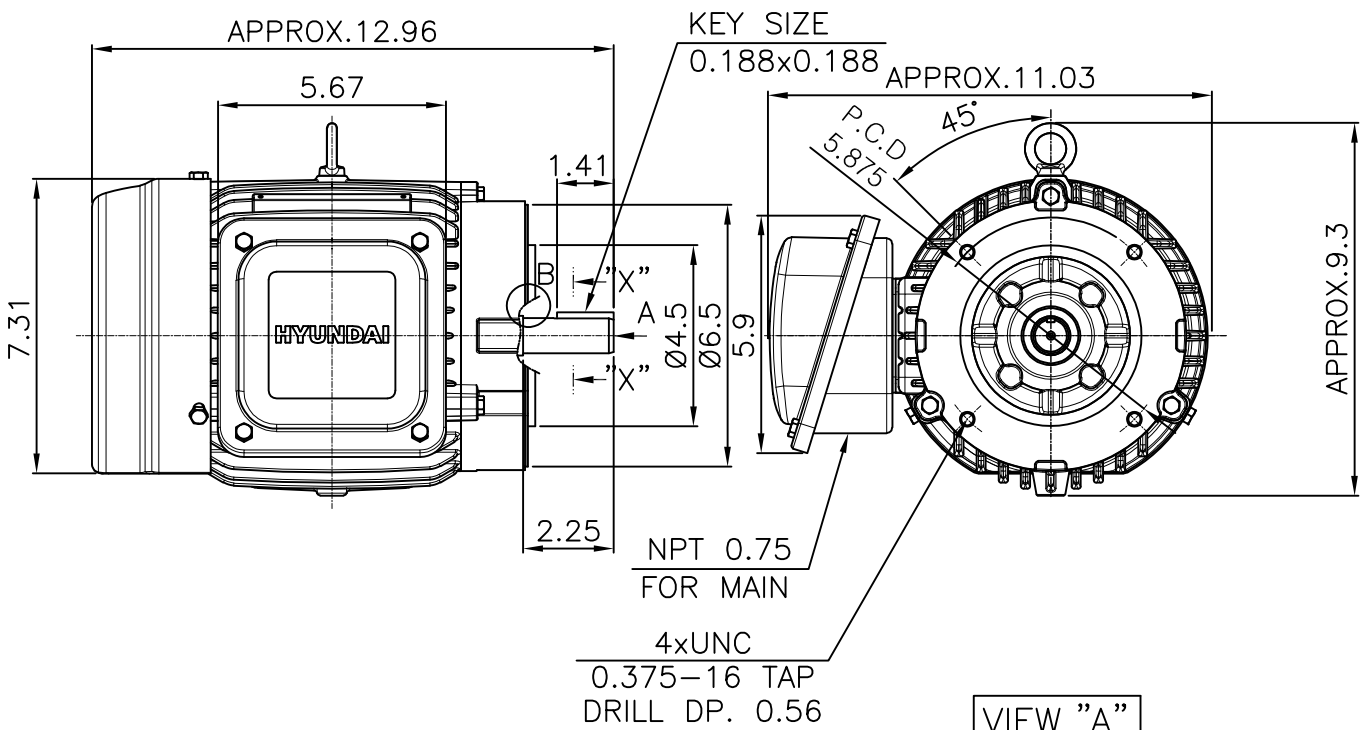

- NOTE**
[TOLERANCE]
- CENTER HEIGHT : +0.00inch - 0.03inch
 - SHAFT DIAMETER : +0.000inch - 0.0005inch
 - KEYWAY DEPTH : +0.000inch - 0.015inch

APPD BY	S.Y.KIM	UNIT	inch	SUBJECT	NEMA 145TC	DWG SIZE	A4 (1:5)
CHKD BY	R.G.KIM	SCALE	1/5	TITLE	OUTLINE	REF. NO	Sheet No. of
CHKD BY		PROJEC'N	3rd Angle				
DSND BY	주유림	DATE	2021-04-28				
				DWG NO	LM-T2145C5PLV23	REF. NO	.
						Revision No.	0



**Cls. I&II, Div. 2
IEEE 841**

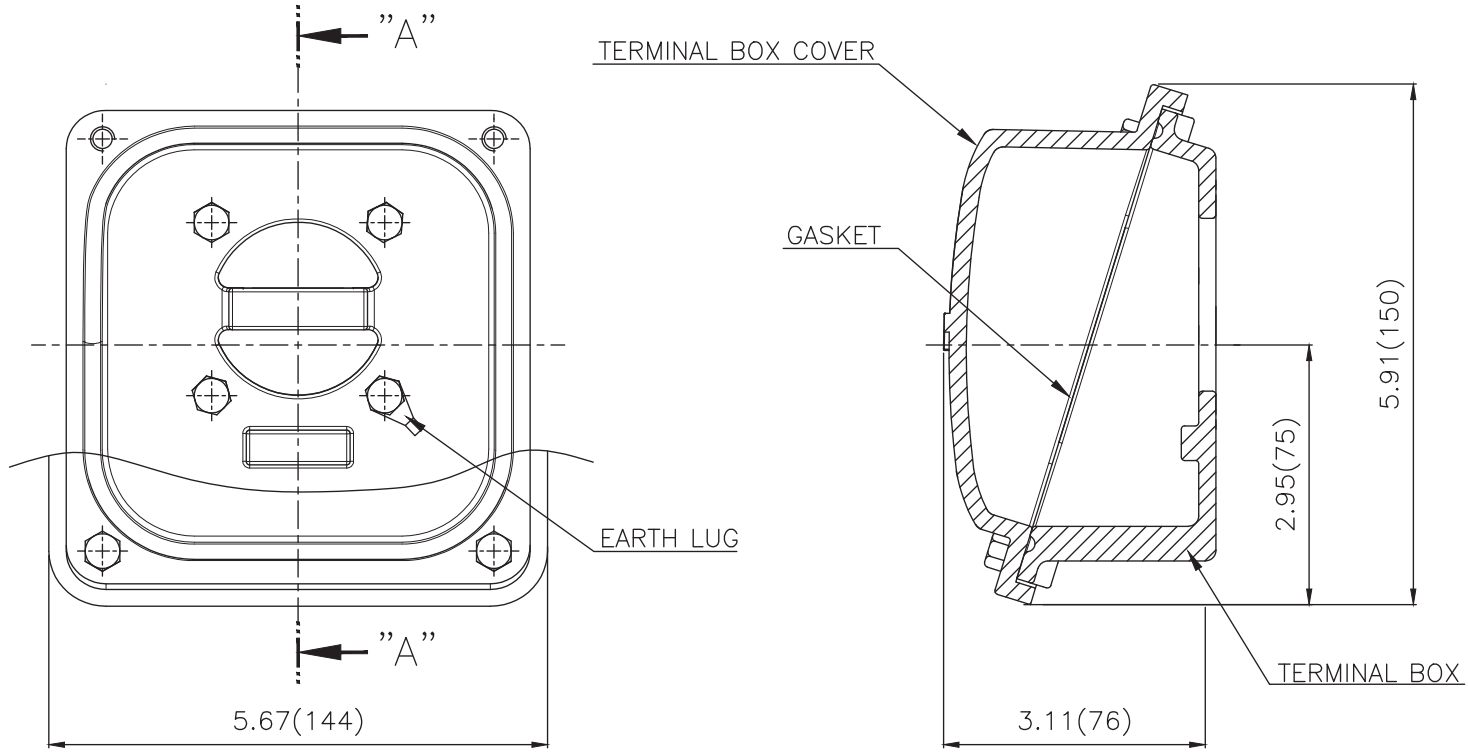

SEC. "A"-"A"

▽	50S
▽▽	12.5S
▽▽▽	3.2S
▽▽▽▽	0.4S

REV	DATE	CONTENTS	REVD BY	CHKD BY	CHKD BY	APPD BY

일반가공공차		일반제관공차	
1-4	±0.1	6-30	±0.5
4-18	±0.2	30-120	±0.8
18-63	±0.3	120-315	±1.2
63-250	±0.5	315-1000	±2.0
250-	±0.8	1000-	±3.0

Q'TY	DESCRIPTION	MATERIAL	DIMENSION	WEIGHT	PART NO.	REMARK	NO.
APPD BY	S.Y.KIM	UNIT	inch(mm)	SUBJECT	FR. 140-180 (CAST IRON)	DWG SIZE	A3 (1:1.5)
CHKD BY		SCALE	1/1.5	TITLE			
CHKD BY	R.G.KIM	PROJEC'N	3rd Angle	TERMINAL BOX ASS'Y			
DSND BY	배승희	DATE	2023-10-19	REF. NO		Sheet No.	of
				DWG NO	3M-248456	Revision No.	0

