

Customer :
Project Name :
Project No. :
Revision No. :

SPECIFICATION for INDUCTION MOTOR



0		For Bidding			
No.	DATE	DESCRIPTION	PREPARED BY	CHECKED BY	APPROVED BY



AC INDUCTION MOTOR DATA SHEET

Explosion Proof type

Catalog No.	IXHH11.5-18-145TC	Item No.		Rev. No.	[]
Project Name		Project No.		Quantity	sets

GENERAL SPECIFICATION			PERFORMANCE DATA			
Frame Size	145TC		Rated Output	1.1 kW		1.5 HP
Type	XJP		Number of Poles	4		
Enclosure(Protection)	Totally Enclosed	/ IP55	Rotor Type	Squirrel Cage		
Method of Cooling	IC411(FC)		Starting Method*	D.O.L		
Rated Frequency	60 Hz		Rated Voltage	575 V	460 V	230 V
Number of Phases	3		Current	Full Load	1.77 A	2.22 A
Insulation Class	F			Locked-rotor**	900 %	900 %
Temp. Rise at full load (by resistance method)			Efficiency			
at 1.0 S.F	80 deg. C		50% Load		83.5 %	
Motor Location	<input type="checkbox"/> Indoor <input type="checkbox"/> Outdoor		75% Load		85.5 %	
Altitude	Less than 1,000 meter		100% Load		86.5 %	
Relative Humidity	Less than 80 %		Power Factor(p.u)			
Ambient Temp.	40 deg. C (Max.)		50% Load		0.570	
Duty Type	Continuous (S1)		75% Load		0.670	
Service Factor	1.15		100% Load		0.720	
Mounting	B35		Speed at Full Load	1750 r.p.m		
Bearing	Type	Anti-Friction	Torque			
	DE/N-DE	6205ZZC3 / 6204ZZC3	Full Load	4.4 lb.ft		
	Lubricant	Grease(Polyrex-EM)	Locked-rotor**	260 %		
External Thrust	Not applicable		Breakdown**	290 %		
Coupling Method	<input checked="" type="checkbox"/> Direct <input type="checkbox"/> V-belt		Moment of Inertia (J)			
Shaft Extension	Single		Load(Max.)	24.278 lb.ft2		
Terminal Box	Main	Cast Iron	Motor	0.076 lb.ft2		
	Aux.	No	Sound Pressure Level (No-load & mean value at 1m from motor)			
	Location	Refer to Outline Drawing	64 dB(A)			
Application			Vibration			
Area classification	Hazardous		0.0 mm/sec (peak)			
Type of Ex-Protection	Class I&II, Division 1		Permissible number of consecutive starts	Cold	0 times	
Applicable Standard	NEMA MG1, CSA C390, UL674		Hot	0 times		
			Paint	Munsell No.	4.0PB5.4/5.5(VL-451)	

ACCESSORIES

*. W.T.D.(Thermostat, 145°C) : 1EA/Ph.

SPARE PARTS

SUBMITTAL DRAWING

Outline Dimension Drawing		Motor Weight(Approx.)	
B35	LM-U0145C4TL001	66 lb.	

REMARK

- Premium efficiency according to NEMA MG1
- Inverter Duty @ 1.0 Service Factor & Ambient max 45°C
 - . CT 10.5Hz to 60Hz (10:1 CT at 1hour Duty)
 - . 10:1 VT (20:1 VT at 50% load)
 - . CHP up to 1.5 times base speed, NEMA MG1 Part31
- Class I, Division 1, Group C&D
 - . Temp.Code(Sine wave) : T2C at 40°C Amb./T2B at 55°C Amb. T4 with Winding Temperature Detector
- Class II, Division 1, Group F&G
 - . Temp.Code(Sine wave) : T3B

Date	DSND	CHKD	CHKD	APPD
2024-08-08	S.H. Lee	I.K. Kim	R.G. Kim	S.W. Kim

[Note] Others not mentioned in this data sheet shall be in accordance with maker standard.
 Above technical data are only design values and shall be guaranteed with tolerance of applicable standard.
 Inspection and performance test shall be done according to maker standard, if not mentioned.
 * In case of Inverter-Fed Motor, performance data is based on sine wave tests. It may be different from test data of Inverter combined motor.
 ** Data is based on rated voltage & frequency and is expressed as a percentage of full-load value.

1	2	3	4
REV	DATE	CONTENTS	REVD BY

4.02

CROWN TRITON **Explosion Proof**   

Premium Efficiency AC 3 Phase Motor

1.5HP	4P	230/460V	Cat. No.	IXHHI1.5-18-145TC		
Model	LATER		INS. Class	F	HD-F1	Amps 4.43/2.22
Type	XJP	Duty	CONT	Code	L	Hertz 60Hz
Frame	145TC	Encl.	TEFC	RPM	1750	Amb. 40°C
<input type="checkbox"/>	Drive	6205ZZC3	S.F.	1.15	on sine wave power	NEMA Design B
	Opp.	6204ZZC3	S.F.	1.00	on PWM or IGBT power	
Usable at	50Hz 1HP 380V 2.2A 1460rpm S.F.: 1.0 Eff.: 79.6% Code: L					
	50Hz 1HP 400/415V 2.2/2.3A 1465/1465rpm S.F.: 1.0 Eff.: 79.6/79.6% Code: L/L					
UL Certified for	Class I, Div.1, Gr. C&D / Class I, Zone1, Gr. IIA & IIB			Temp. Code	T2C at 40°C Amb. / T2B at 55°C Amb.	
	10:1VT(20:1 at 50% load) CT 10.5Hz to base Hz(10:1 1hour duty at lowest RPM)			(sine wave)		
	CHP upto 1.5 time base speed,NEMA MG1 part 31.Amb max 45°C for inverter duty.					
No.	-	Date	-	Weight	66 lb	



1.81

APPD BY	S.Y.KIM	UNIT	INCH	SUBJECT	UL Class I, Division1 (IXHHI)	DWG SIZE
CHKD BY	I.K.KIM	SCALE	NONE			A4 (1:1)
CHKD BY	R.G.KIM	PROJEC'N	3rd Angle	TITLE NAMEPLATE DRAWING		
DSND BY	S.H.LEE	DATE	2024.06.07			
				REF. NO	NP249A7177V	Sheet No. of
				DWG NO	NP-IXHHI1.5-18-145TC	Revision No. 0

Type :	XJP
Full Load Torque :	4.4 lb.ft
Load moment of Inertia (J) :	24.278 lb.ft ²
Motor moment of Inertia (J) :	0.076 lb.ft ²

1.1kW	1.5HP	4 P	60 Hz
Speed at Full Load :			1750 RPM
Rated Voltage	575V	460V	230V
Full Load Current	1.8A	2.2A	4.4A

SPEED VS TORQUE & CURRENT CURVE

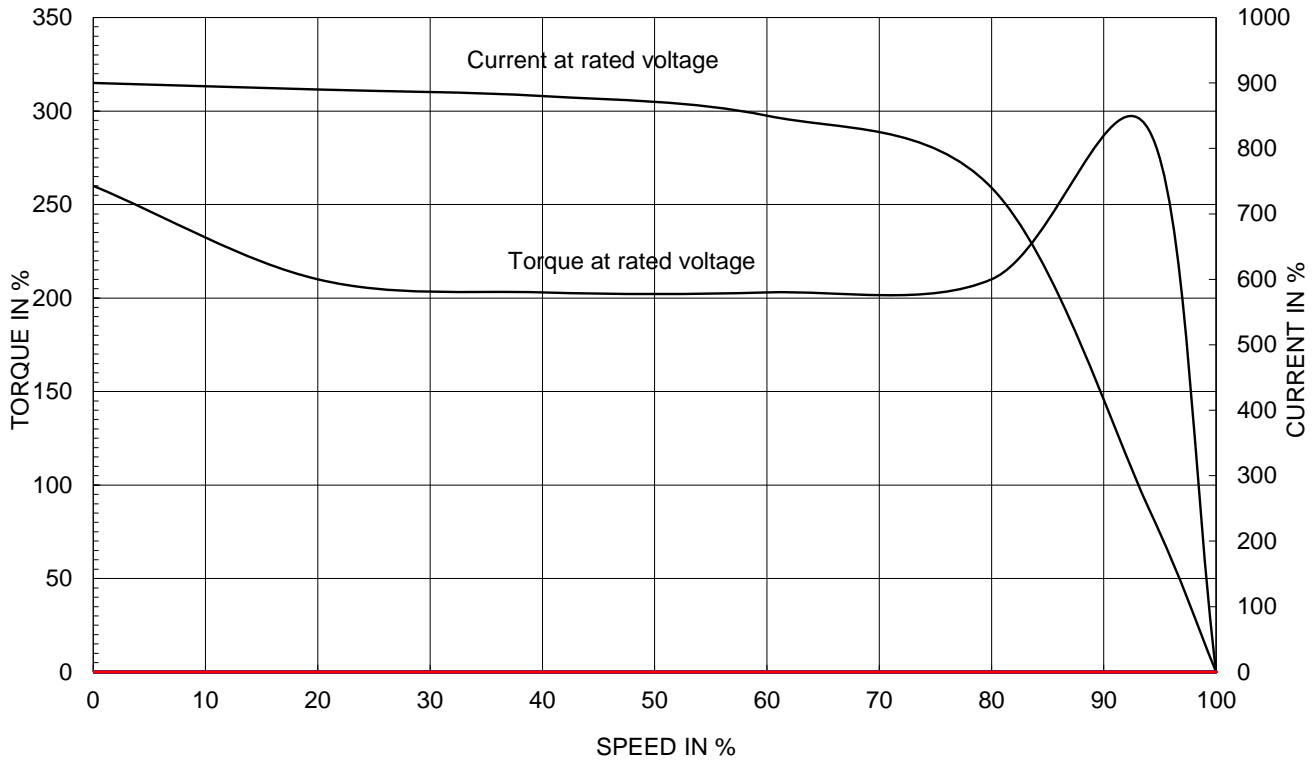

OUTPUT VS EFF., P.F & CURRENT CURVE

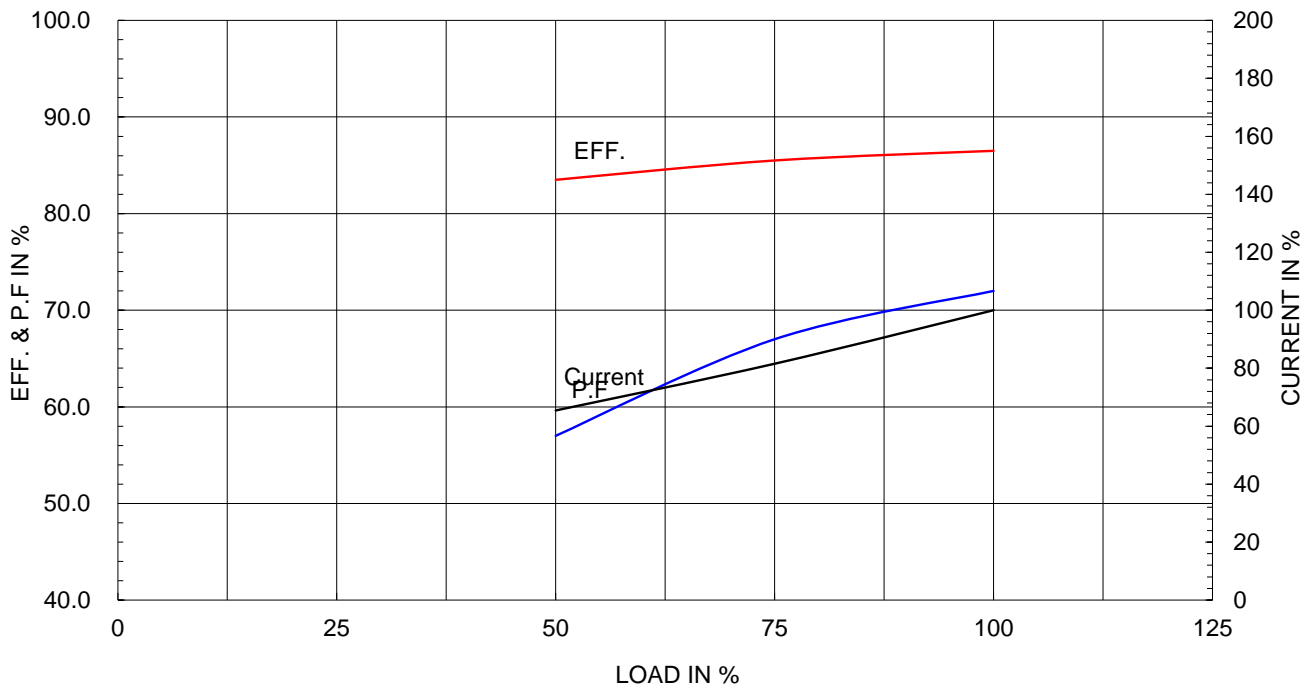

본 도면은 HD현대일렉트릭(주) 재산이며 허가없이 복사할 수 없음 (취급주의)

THIS DRAWING IS PROPRIETARY TO HYUNDAI ELECTRIC. NO PART OF THIS DRAWING MAYBE REPRODUCED WITHOUT THE PERMISSION OF HYUNDAI ELECTRIC.

1	2	3	4
▽	50S	REV	DATE
▽▽	12.5S		
▽▽▽	3.2S		
▽▽▽▽	0.4S		

Class I Division 1

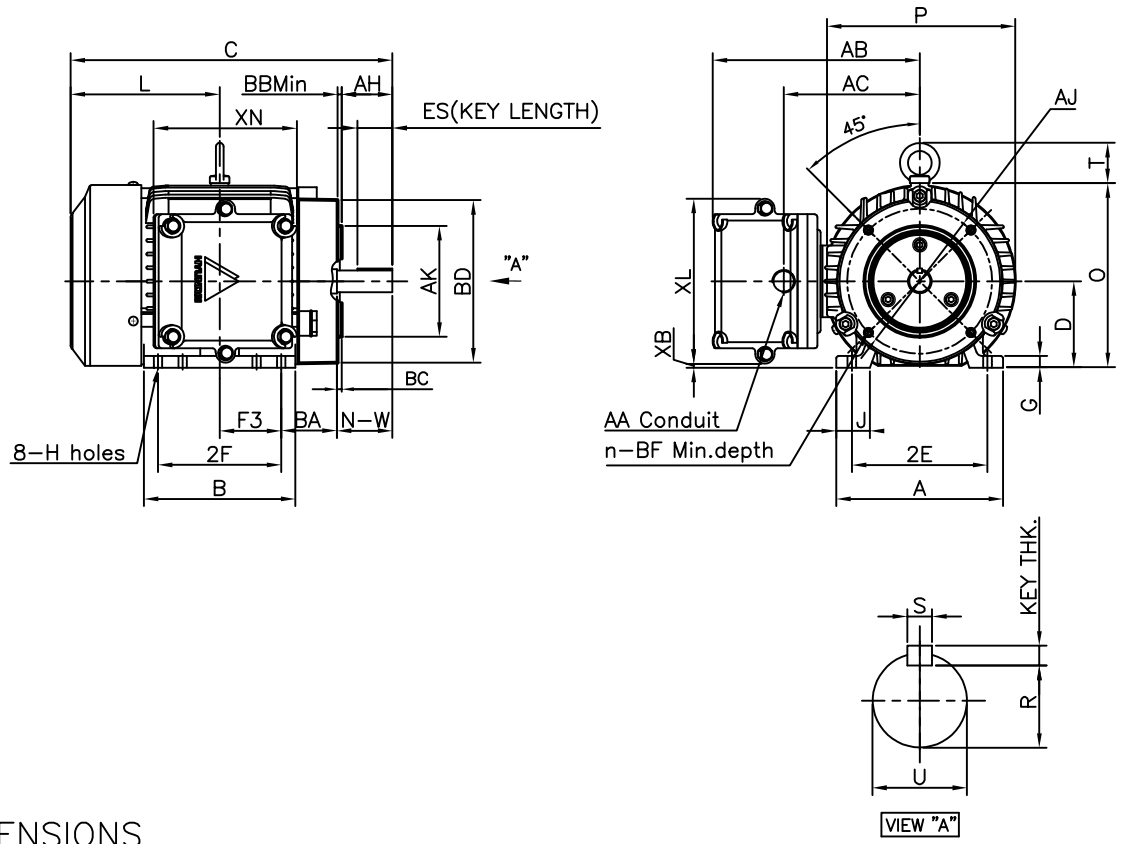

DIMENSIONS

MOUNTING									CONDUIT BOX						APPROX. WGT.(LB)
A	B	2E	-	2F	F3	G	J	H	AA	AB	AC	XB	XL	XN	
6.78	6.15	5.50	-	5.00	2.50	0.45	1.36	0.34	0.75	8.54	5.59	0.15	6.70	5.98	66

OVERALL							SHAFT				KEY	BEARING		
BA	C	D	L	O	P	T	U	N-W	KEYWAY			THK.	DRIVE END	OPP. DRIVE END
									R	ES	S			
2.25	13.05	3.50	6.05	7.46	7.64	1.63	0.875	2.25	0.771	1.41	0.188	0.188	6205ZZ	6204ZZ

C-FACE								
AJ	AK	BBmin	BC	BD	BF	BF Def.	n	AH
5.875	4.50	0.16	+0.12	6.50	3/8-16	0.56	4	2.12

NOTE

- 1.Dimension "D" tolerance : +0.00inch ~ -0.03inch (143TC-365TC) : +0.000inch ~ -0.06inch (404TC-449TC)
- 2.Dimension "U" tolerance : +0.000inch ~ -0.0005inch (143TC-215TC) : +0.000inch ~ -0.001inch (254TC-449TC)
- 3.Dimension "R" tolerance : +0.000inch ~ - 0.015inch
- 4.Dimension "AK" tolerance : +0.000inch ~ -0.003inch (143TC-286TC) : +0.000inch ~ -0.005inch (324TC-449TC)

APPD BY	S.Y.KIM	UNIT	inch	SUBJECT	NEMA 145TC(KIT)	DWG SIZE
CHKD BY	R.G.KIM	SCALE	1/8	TITLE	OUTLINE	A4 (1:8)
CHKD BY		PROJEC'N	3rd Angle			
DSND BY	J.H.JEON	DATE	2021-06-08			



REF. NO		Sheet No.	of
DWG NO	LM-U0145C4TL001	Revision No.	0



Cls. I Div. 1

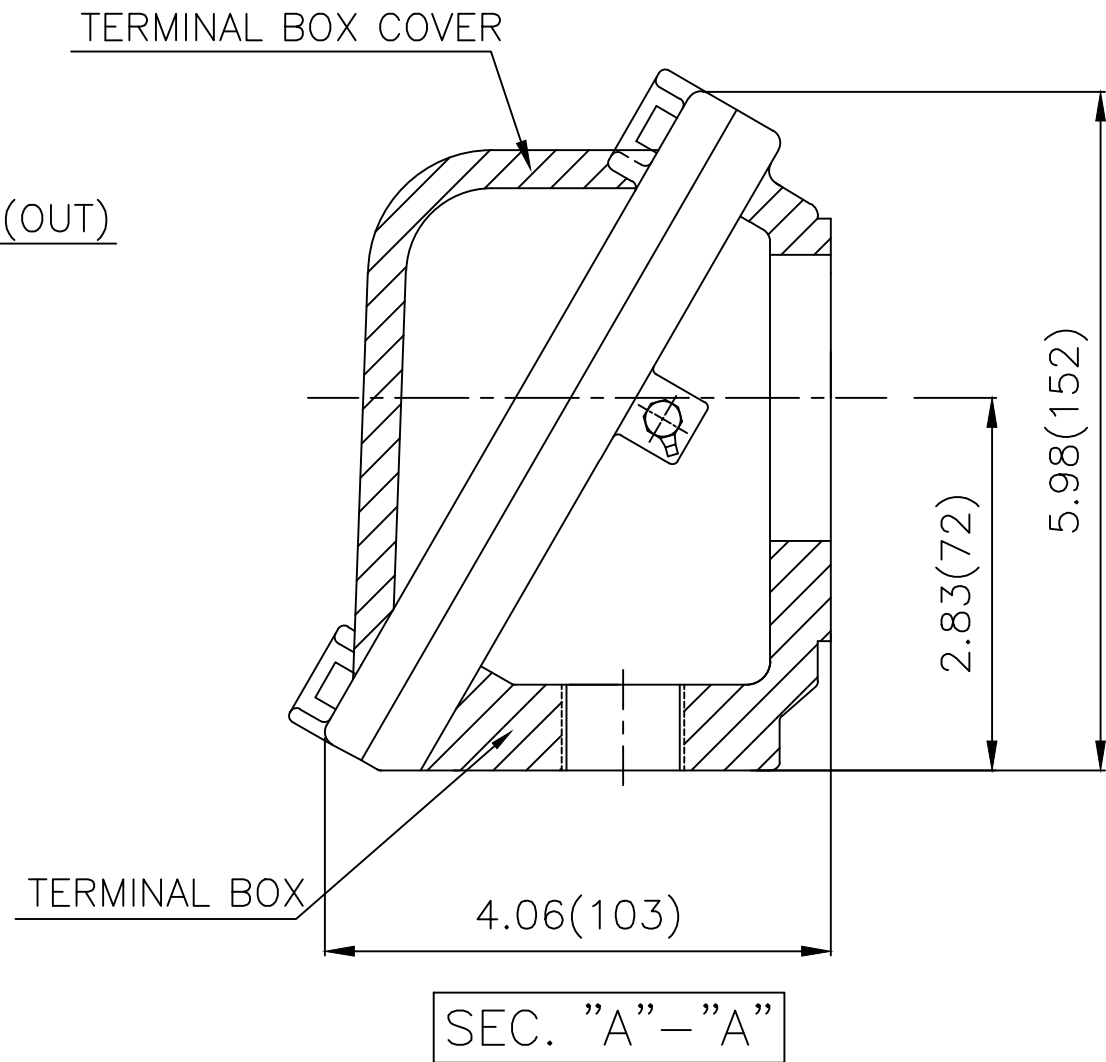
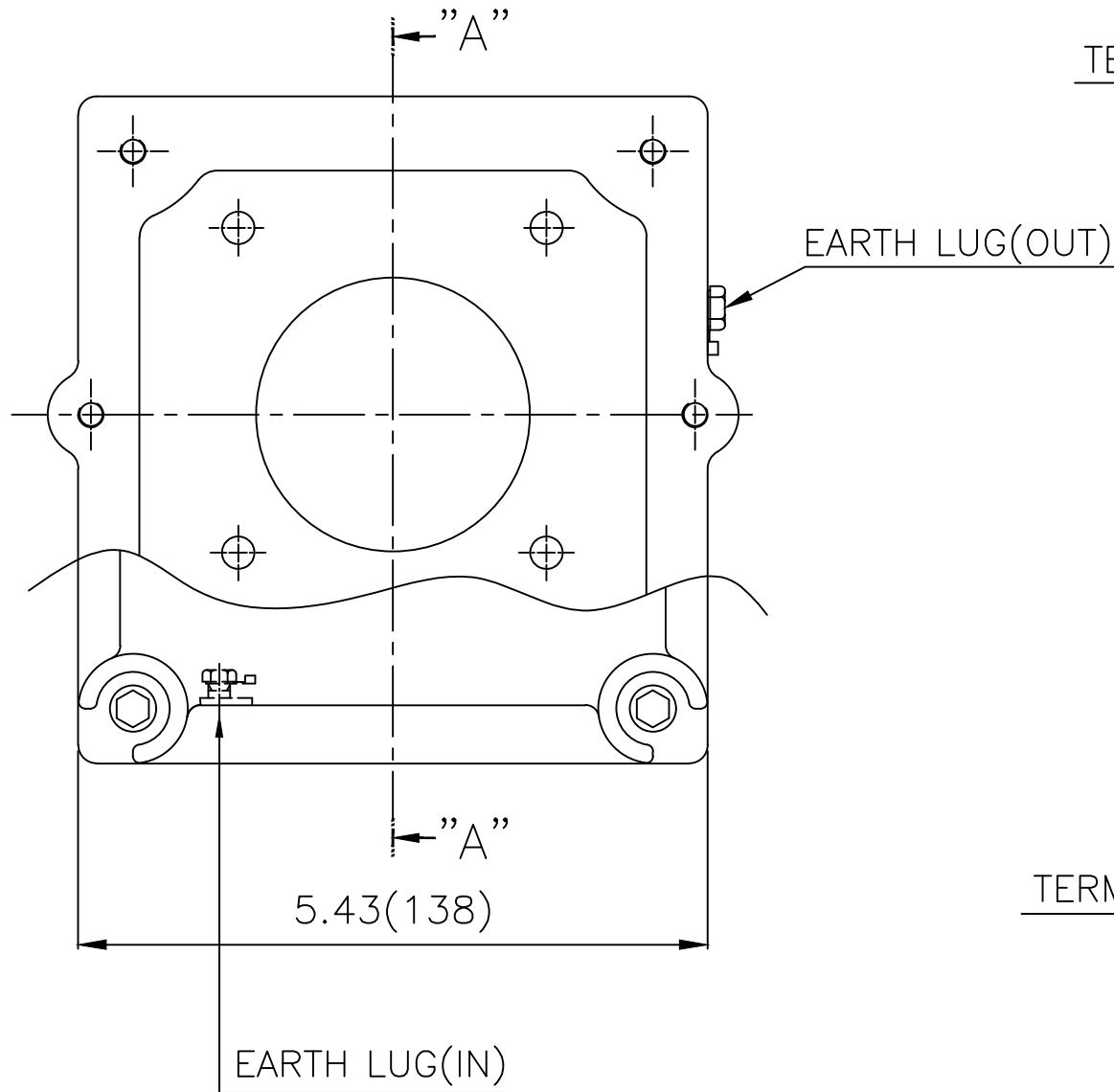

▽	50S
▽▽	12.5S
▽▽▽	3.2S
▽▽▽▽	0.4S

REV	DATE	CONTENTS	REVD BY	CHKD BY	CHKD BY	APPD BY

일반가공공차		일반제관공차	
1-4	±0.1	6-30	±0.5
4-18	±0.2	30-120	±0.8
18-63	±0.3	120-315	±1.2
63-250	±0.5	315-1000	±2.0
250-	±0.8	1000-	±3.0

Q'TY	DESCRIPTION	MATERIAL	DIMENSION	WEIGHT	PART NO.	REMARK	NO.
APPD BY	S.Y.KIM	UNIT	lφφh(mm)	SUBJECT	NEMA FR. 180~210(CAST IRON)	DWG SIZE	A3 (1:1.5)
CHKD BY	R.G.KIM	SCALE	1/1.5	TITLE	MAIN TERMINAL BOX ASS'Y		
CHKD BY		PROJEC'N	3rd Angle	REF. NO		Sheet No.	of
DSND BY	김은진	DATE	2023-10-24	DWG NO	3M-248496	Revision No.	0

