

Customer :  
 Project Name :  
 Project No. :  
 Revision No. :

# SPECIFICATION for INDUCTION MOTOR



0		For Bidding			
No.	DATE	DESCRIPTION	PREPARED BY	CHECKED BY	APPROVED BY



# AC INDUCTION MOTOR DATA SHEET

## IEEE841 TYPE

Catalog No.	IEEE500-36-5010SC-IBBRSRSHSP	Item No.	Rev. No. [      ]
Project Name		Project No.	Quantity                      sets

GENERAL SPECIFICATION		PERFORMANCE DATA			
Frame Size	5010SC	Rated Output	375 kW                      500 HP		
Type	PJP	Number of Poles	2		
Enclosure(Protection)	Totally Enclosed / IP55	Rotor Type	Squirrel Cage		
Method of Cooling	IC411(FC)	Starting Method*	D.O.L		
Rated Frequency	60 Hz	Rated Voltage	575 V	460 V	230 V
Number of Phases	3	Current	Full Load	436.7 A	545.9 A
Insulation Class	F		Locked-rotor**	725 %	725 %
Temp. Rise at full load (by resistance method)		Efficiency			
at 1.0 S.F	80 deg. C	50% Load		92.8 %	
Motor Location	<input type="checkbox"/> Indoor <input type="checkbox"/> Outdoor	75% Load		94.8 %	
Altitude	Less than 1,000 meter	100% Load		95.8 %	
Relative Humidity	Less than 80 %	Power Factor(p.u)			
Ambient Temp.	40 deg. C (Max.)	50% Load		0.750	
Duty Type	Continuous ( S1 )	75% Load		0.850	
Service Factor	1.15	100% Load		0.900	
Mounting	B35	Speed at Full Load	3570 r.p.m		
Bearing	Type	Anti-Friction	Torque		
	DE/N-DE	6315C3 / 6315C3-INS.	Full Load	740.0 lb.ft	
	Lubricant	Grease(Polyrex-EM)	Locked-rotor**	145 %	
External Thrust	Not applicable	Breakdown**	240 %		
Coupling Method	<input checked="" type="checkbox"/> Direct <input type="checkbox"/> V-belt	Moment of Inertia (J)			
Shaft Extension	Single	Load(Max.)	381.000 lb.ft2		
Terminal	Main	Motor	76.418 lb.ft2		
Box	Aux.	Sound Pressure Level (No-load & mean value at 1m from motor)			
	Location	Refer to Outline Drawing			
Application		Vibration	3.8 mm/sec (peak)		
Area classification	Hazardous	Permissible number of consecutive starts	Cold	2 times	
Type of Ex-Protection	Class I&II, Division 2		Hot	1 time	
Applicable Standard	IEEE841, NEMA MG1, CSA C390	Paint	Munsell No.	7.5BG6/1.5	

ACCESSORIES
*. B.T.D.(Pt 100 Ω at 0°C,Single) : 2EA/Motor
*. W.T.D.(Pt 100 Ω at 0°C) : 2EA/Ph.
*. Space Heater : 1EA/Motor

SPARE PARTS
1. Spare Axial Fan (C.W Direction)

SUBMITTAL DRAWING		
Outline Dimension Drawing	Motor Weight(Approx.)	
B35	LM-I0511C4C7001	4940 lb.

**REMARK**

1. Premium efficiency according to NEMA MG1
2. Inverter Duty @ 1.0 Service Factor & F Temperature rise
  - . 10:1 VT (20:1 VT at 50% load)
  - . 10:1 CT
  - . CHp up to 1.5 times base speed, NEMA MG1 Part31
3. NDE side : Insulated bearing
4. CSA Certification
  - . Class I, Division 2, Group A, B, C & D; Temp code : T3
  - . Class II, Division 2 Group F & G; Temp code : T3
5. Shaft material : AISI4140
6. Uni-directional CCW viewed from drive end.

Date	DSND	CHKD	CHKD	APPD
2024-09-22	E.J.LEE	I.K. Kim	R.G. Kim	S.W. Kim

[Note] Others not mentioned in this data sheet shall be in accordance with maker standard.  
 Above technical data are only design values and shall be guaranteed with tolerance of applicable standard.  
 Inspection and performance test shall be done according to maker standard, if not mentioned.  
 \* In case of Inverter-Fed Motor, performance data is based on sine wave tests. It may be different from test data of Inverter combined motor.  
 \*\* Data is based on rated voltage & frequency and is expressed as a percentage of full-load value.

1	2	3	4
REV	DATE	CONTENTS	REVD BY CHKD BY CHKD BY APPD BY

4.72

**CROWN TRITON**  
Premium Efficiency AC 3 Phase Motor

500HP 2P 460V		Cat. No. IEEE500-36-5010SC-IBBRSRSHSP	
Model	LATER	INS. Class	F
Type	PJP	Duty	CONT
Frame	5010SC	Encl.	TEFC
Bearing	Drive	6315C3	S.F.1.00 (10:1 C.T., 20:1 V.T., NEMA-MG1 Part31)
	Opp.	6315C3-INS.	
Usable at	50Hz 420HP 380V 555.08A 2970rpm S.F.: 1.0 Eff.: 95.8% Code: G		
	50Hz 420HP 400/415V 533.25/513.93A 2972/2975rpm S.F.: 1.0 Eff.: 95.8/95.81% Code: H/J		
CSA Certified for	CLASS I, Div. 2, Gr. A, B, C & D	CLASS II, Div. 2, Gr. F & G	Temp. Code
	CLASS I, Zone 2, Gr. IIA, IIB, & IIC		(sine wave)
			Frame
No.	-	Date	-
		Weight	4940 lb

**IEEE Std 841-2021**  
4M-136054

**MARINE DUTY IEEE45**  
Made in Korea H1

2.36

APPD BY	S.Y.KIM	UNIT	INCH	SUBJECT	CSA Class I, Division2 IEEE841 (XL)	DWG SIZE
CHKD BY	I.K.KIM	SCALE	NONE			A4 ( 1:1 )
CHKD BY	R.G.KIM	PROJEC'N	3rd Angle	<div style="font-size: 24px; font-weight: bold;">NAMEPLATE DRAWING</div>		
DSND BY	S.H.LEE	DATE	2024.06.07			
				REF. NO	<b>4M-136054</b>	Sheet No. of
				DWG NO	NP-IEEE500-36-5010SC-IBBRSRSHSP	Revision No. <b>0</b>

Type :	PJP
Full Load Torque :	740.0 lb.ft
Load moment of Inertia (J) :	381.000 lb.ft2
Motor moment of Inertia (J) :	76.418 lb.ft2

375kW	500HP	2 P	60 Hz
Speed at Full Load :			3570 RPM
Rated Voltage	575V	460V	230V
Full Load Current	436.7A	545.9A	1091.8A

SPEED VS TORQUE & CURRENT CURVE

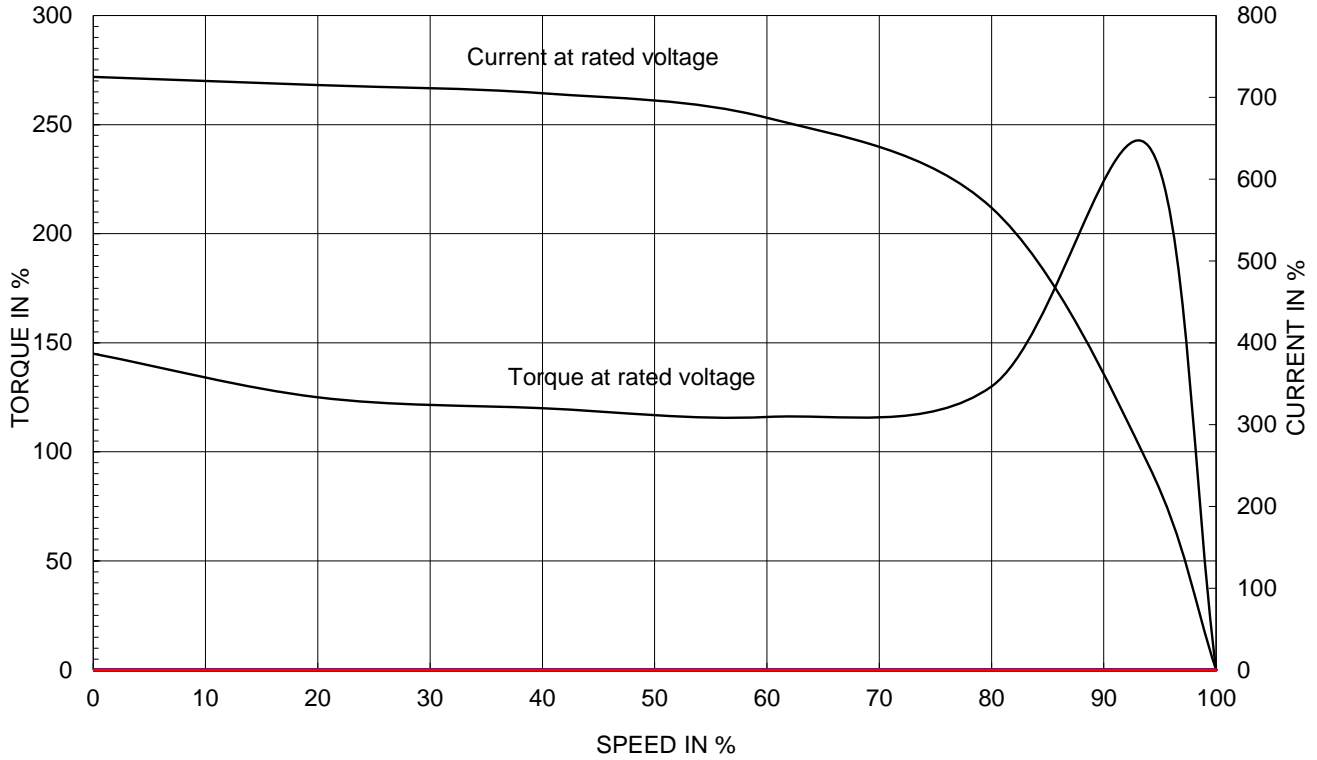

OUTPUT VS EFF., P.F & CURRENT CURVE

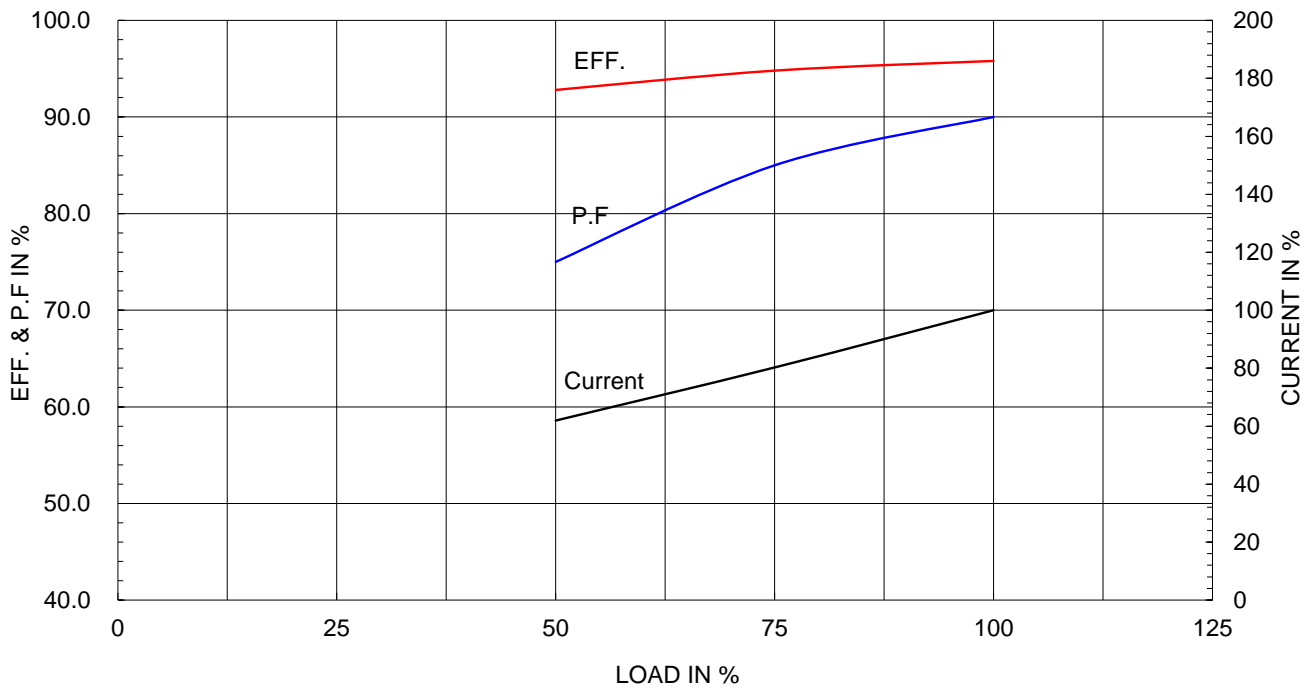

▽	50S	REV	DATE	CONTENTS	REVD BY	CHKD BY	CHKD BY	APPD BY
▽▽	12.5S							
▽▽▽	3.2S							
▽▽▽▽	0.4S							

**IEEE841**

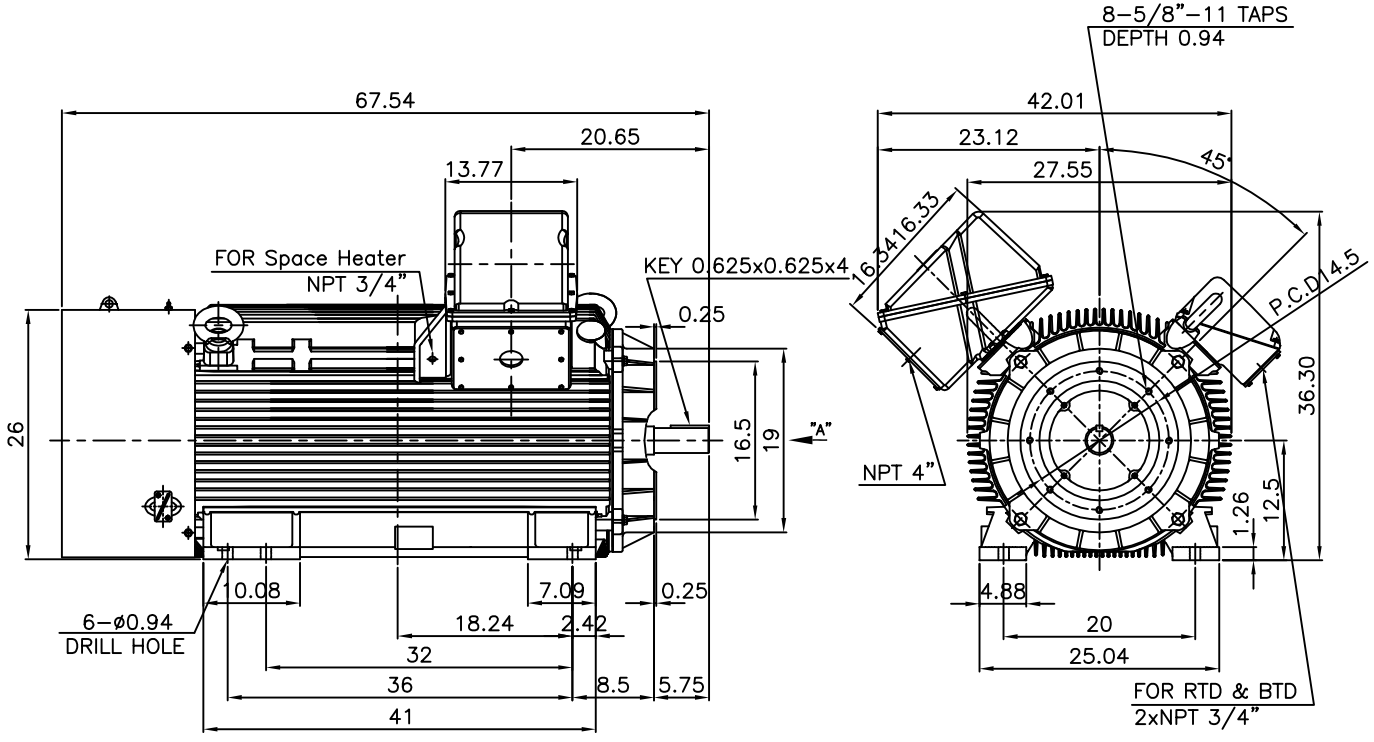

**NOTE**

1.TOLERANCE :

CENTER HEIGHT	12.5	+0.000	-0.060
RABBET DIAMETER	∅16.5	+0.000	-0.005
SHAFT DIAMETER	∅2.625	+0.000	-0.001
KEYWAY WIDTH	0.625	+0.002	-0.000

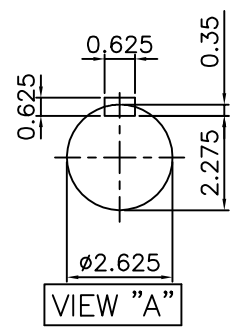

APPD BY	S.Y.KIM	UNIT	INCH	SUBJECT	Fr.5010/5011SC	DWG SIZE	A4 (1:20)
CHKD BY	O.J.KIM	SCALE	1/20	TITLE	OUTLINE	REF. NO	Sheet No. of
CHKD BY	R.G.KIM	PROJEC'N	3각법(3rd Angle)				
DSND BY	H.K.LEE	DATE	2021-04-27	DWG NO	LM-I0511C4C7001	Revision No.	0



REF. NO: Sheet No. of  
 DWG NO: LM-I0511C4C7001 Revision No. 0

**Cls. I&II, Div. 2  
IEEE 841**

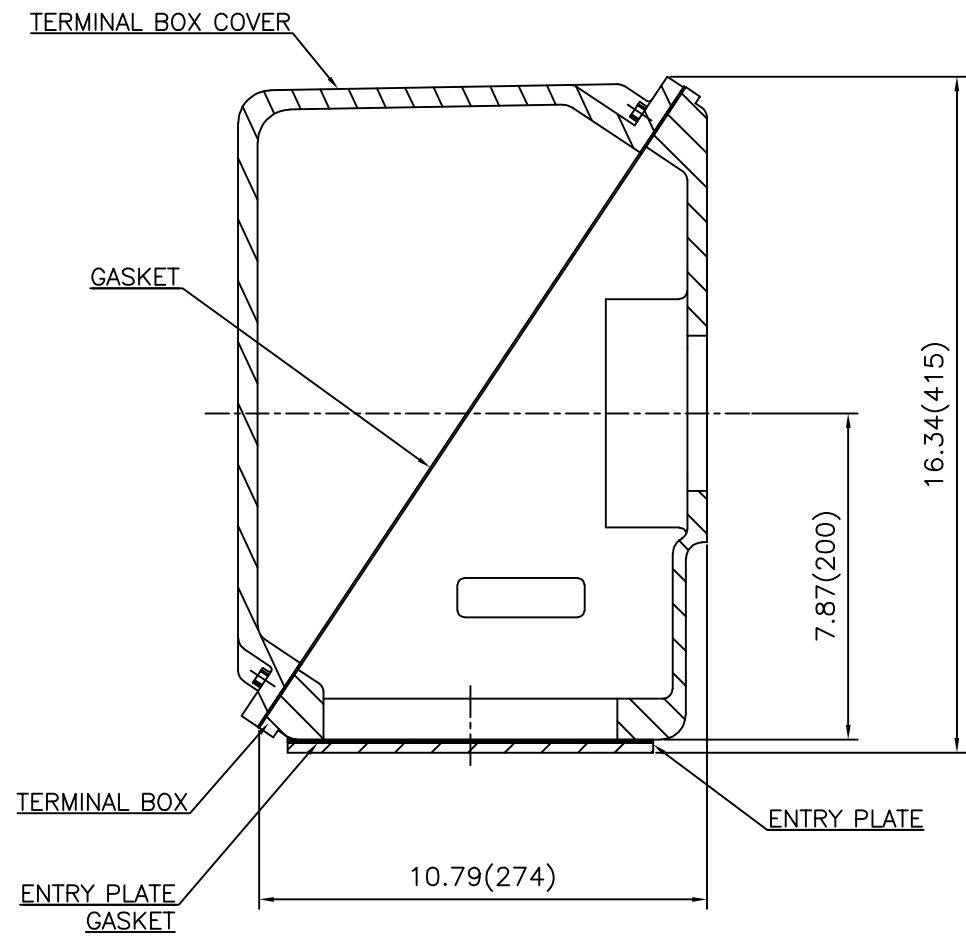
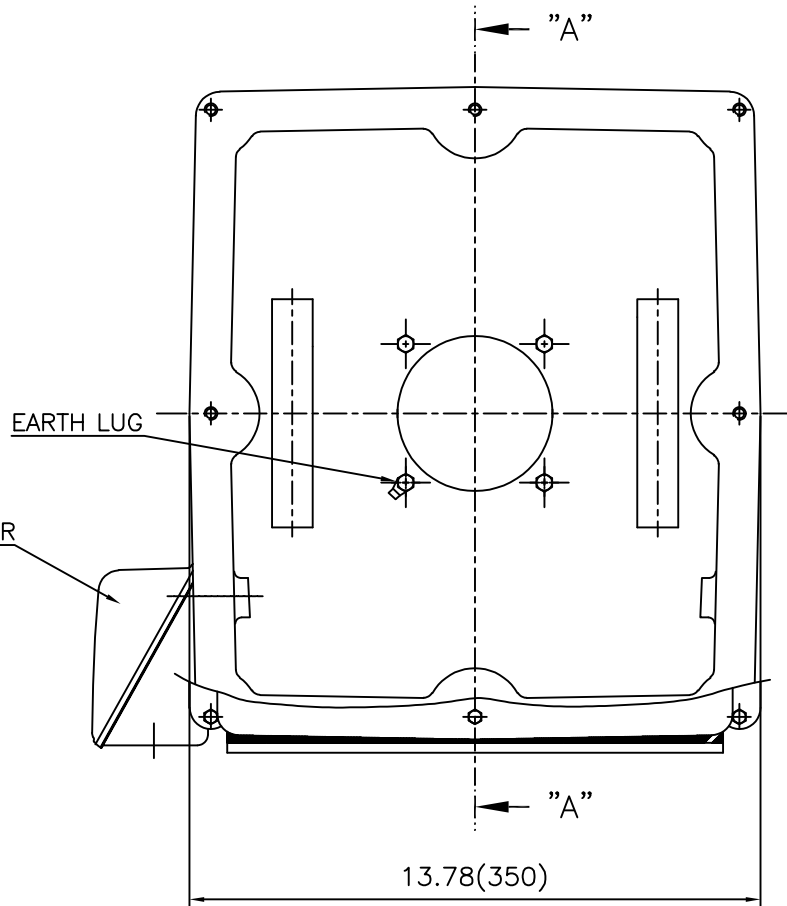

SEC. "A" - "A"

REV	DATE	CONTENTS	REVD BY	CHKD BY	CHKD BY	APPD BY

APPD BY	S.Y.KIM	UNIT	inch(mm)	SUBJECT	FR. L440 (CAST IRON)	DWG SIZE
CHKD BY		SCALE	1/3.5	TITLE	MAIN TERMINAL BOX ASS'Y	A3 (1:3.5)
CHKD BY	R.G.KIM	PROJEC'N	3rd Angle			
DSND BY	최승희	DATE	2023-10-19	REF. NO		Sheet No. of
				DWG NO	3M-248452	Revision No. 0

# Cls. I&II, Div. 2 IEEE 841

본 도면은 HD현대일렉트릭(주) 재산이며  
허가없이 복사할 수 없음 (취급주의)

THIS DRAWING IS PROPRIETARY TO HYUNDAI ELECTRIC. NO PART OF THIS DRAWING  
MAY BE REPRODUCED WITHOUT THE PERMISSION OF HYUNDAI ELECTRIC.



REV	DATE	CONTENTS	REVD BY	CHKD BY	CHKD BY	APPD BY

APPD BY	S.Y.KIM	UNIT	inch(mm)	SUBJECT	FR.360 (CAST IRON)	DWG SIZE	A3 (1:2.2)
CHKD BY		SCALE	1/1	TITLE	AUX. TERMINAL BOX ASS'Y	REF. NO	Sheet No. of
CHKD BY	R.G.KIM	PROJEC'N	3rd Angle	DSND BY		네슬렉	DATE
				DWG NO	3M-165277	Revision No. 0	

**Cls. I&II, Div. 2  
IEEE 841**



REV	DATE	CONTENTS	REVD BY	CHKD BY	CHKD BY	APPD BY

APPD BY	S.Y.KIM	UNIT	inch(mm)	SUBJECT	FR.180 (CAST IRON)	DWG SIZE
CHKD BY		SCALE	1/1	TITLE	SUB. TERMINAL BOX ASS'Y	A3 (1:1.1)
CHKD BY	R.G.KIM	PROJEC'N	3rd Angle			
DSND BY	배승희	DATE	2024-01-18			
				REF. NO		Sheet No. of
				DWG NO	3M-165278	Revision No. 0