

Customer :
 Project Name :
 Project No. :
 Revision No. :

SPECIFICATION for INDUCTION MOTOR



0		For Bidding			
No.	DATE	DESCRIPTION	PREPARED BY	CHECKED BY	APPROVED BY



AC INDUCTION MOTOR DATA SHEET

Catalog No.	HSDE250-12-L449TC-IBBRSRSH	Item No.		Rev. No.	[]
Project Name		Project No.		Quantity	sets

GENERAL SPECIFICATION			PERFORMANCE DATA		
Frame Size	L449TC		Rated Output	190 kW 250 HP	
Type	PJP		Number of Poles	6	
Enclosure(Protection)	Totally Enclosed	/ IP55	Rotor Type	Squirrel Cage	
Method of Cooling	IC411(FC)		Starting Method*	D.O.L	
Rated Frequency	60 Hz		Rated Voltage	575 V	460 V 230 V
Number of Phases	3		Current	Full Load	237.1 A 296.3 A 592.7 A
Insulation Class	F			Locked-rotor**	680 % 680 % 680 %
Temp. Rise at full load (by resistance method)			Efficiency		
at 1.0 S.F	80 deg. C		50% Load 92.8 %		
Motor Location	<input type="checkbox"/> Indoor <input type="checkbox"/> Outdoor		75% Load 94.8 %		
Altitude	Less than 1,000 meter		100% Load 95.8 %		
Relative Humidity	Less than 80 %		Power Factor(p.u)		
Ambient Temp.	40 deg. C (Max.)		50% Load 0.690		
Duty Type	Continuous (S1)		75% Load 0.790		
Service Factor	1.15		100% Load 0.840		
Mounting	B35		Speed at Full Load	1185 r.p.m	
Bearing	Type	Anti-Friction	Torque		
	DE/N-DE	6322C3 / 6318C3-INS.	Full Load	1,129.6 lb.ft	
	Lubricant	Grease(Polyrex-EM)	Locked-rotor**	135 %	
External Thrust	Not applicable		Breakdown**	200 %	
Coupling Method	<input checked="" type="checkbox"/> Direct <input type="checkbox"/> V-belt		Moment of Inertia (J)		
Shaft Extension	Single		Load(Max.)	2,740.000 lb.ft2	
Terminal Box	Main	Cast Iron	Motor	158.295 lb.ft2	
	Aux.	Yes	Sound Pressure Level (No-load & mean value at 1m from motor)		
	Location	Refer to Outline Drawing	80 dB(A)		
Application			Vibration 3.8 mm/sec (peak)		
Area classification	Hazardous		Permissible number of consecutive starts	Cold 2 times	
Type of Ex-Protection	Class I&II, Division 2			Hot 1 time	
Applicable Standard	NEMA MG1, CSA C390		Paint	Munsell No.	4.0PB5.4/5.5(VL-451)

ACCESSORIES
*. B.T.D.(Pt 100 Ω at 0°C,Single) : 2EA/Motor
*. W.T.D.(Pt 100 Ω at 0°C) : 2EA/Ph.
*. Space Heater : 1EA/Motor

SPARE PARTS

SUBMITTAL DRAWING		
Outline Dimension Drawing	Motor Weight(Approx.)	
B35	LM-T044XC4U7001	2990 lb.

REMARK
1. Premium efficiency according to NEMA MG1
2. Inverter Duty @ 1.0 Service Factor & F Temperature rise
- 10:1 VT (20:1 VT at 50% load)
- 10:1 CT
- CHp up to 1.5 times base speed, NEMA MG1 Part31
3. NDE side : Insulated bearing
4. CSA Certification
- Class I, Division 2, Group A, B, C & D; Temp code : T3
- Class II, Division 2 Group F & G; Temp code : T3
5. Shaft material : AISI4140

Date	DSND	CHKD	CHKD	APPD
2024-09-10	S.H. Lee	I.K. Kim	R.G. Kim	S.W. Kim

[Note] Others not mentioned in this data sheet shall be in accordance with maker standard.
 Above technical data are only design values and shall be guaranteed with tolerance of applicable standard.
 Inspection and performance test shall be done according to maker standard, if not mentioned.
 * In case of Inverter-Fed Motor, performance data is based on sine wave tests. It may be different from test data of Inverter combined motor.
 ** Data is based on rated voltage & frequency and is expressed as a percentage of full-load value.

본 도면은 HD현대일렉트릭(주) 재산이며
허가없이 복사할 수 없음 (취급주의)

THIS DRAWING IS PROPRIETARY TO HYUNDAI ELECTRIC. NO PART OF THIS DRAWING
MAYBE REPRODUCED WITHOUT THE PERMISSION OF HYUNDAI ELECTRIC.

1	2	3	4
REV	DATE	CONTENTS	REVD BY CHKD BY CHKD BY APPD BY

4.72

CROWN TRITON
Premium Efficiency AC 3 Phase Motor

250HP	6P	460V	Cat. No. HSDE250-12-L449TC-IBBRSRSH
Model	LATER	INS. Class	F
Type	PJP	Duty	CONT
Code	H	Amb.	40°C
Hertz	60Hz		
Frame	L449TC	Encl.	TEFC
S.F.	1.15	RPM	1185
NEMA Nom. Eff.	95.8%		
Bearing	Drive	6322C3	S.F.1.00 (10:1 C.T., 20:1 V.T., NEMA-MG1 Part31)
	Opp.	6318C3-INS.	
Usable at	50Hz 200HP 380V 283.8A 985rpm S.F.: 1.0 Eff.: 95.6% Code: H		
	50Hz 200HP 400/415V 283.09/287.22A 986/987rpm S.F.: 1.0 Eff.: 95.6/95.6% Code: J/J		
CSA Certified for	CLASS I, Div. 2, Gr. A, B, C & D		Temp. Code (sine wave)
	CLASS I, Zone 2, Gr. IIA, IIB, & IIC		
	CLASS II, Div. 2, Gr. F & G		
Frame	L440FR - 500FR		
Amb. 40°C	T3 (200°C)		
Amb. 55°C	T3 (200°C)		
No.	-	Date	-
Weight	2990 lb		

4M-136053
MARINE DUTY IEEE45

Made in Korea H1

2.36

APPD BY	S.Y.KIM	UNIT	INCH	SUBJECT	CSA Class I, Division2 Severe Duty (HSDE ,L449-500)	DWG SIZE
CHKD BY	I.K.KIM	SCALE	NONE	<p>TITLE</p> <p>NAMEPLATE DRAWING</p>		A4 (1:1)
CHKD BY	R.G.KIM	PROJEC'N	3rd Angle			
DSND BY	S.H.LEE	DATE	2024.06.07			
						REF. NO
				DWG NO	NP-HSDE250-12-L449TC-IBBRSRSH	Revision No. 0

1
2
3
4

Type :	PJP
Full Load Torque :	1129.6 lb.ft
Load moment of Inertia (J) :	2740.000 lb.ft ²
Motor moment of Inertia (J) :	158.295 lb.ft ²

190kW 250HP	6 P	60 Hz
Speed at Full Load :		1185 RPM
Rated Voltage	575V	460V 230V
Full Load Current	237.1A	296.3A 592.7A

SPEED VS TORQUE & CURRENT CURVE

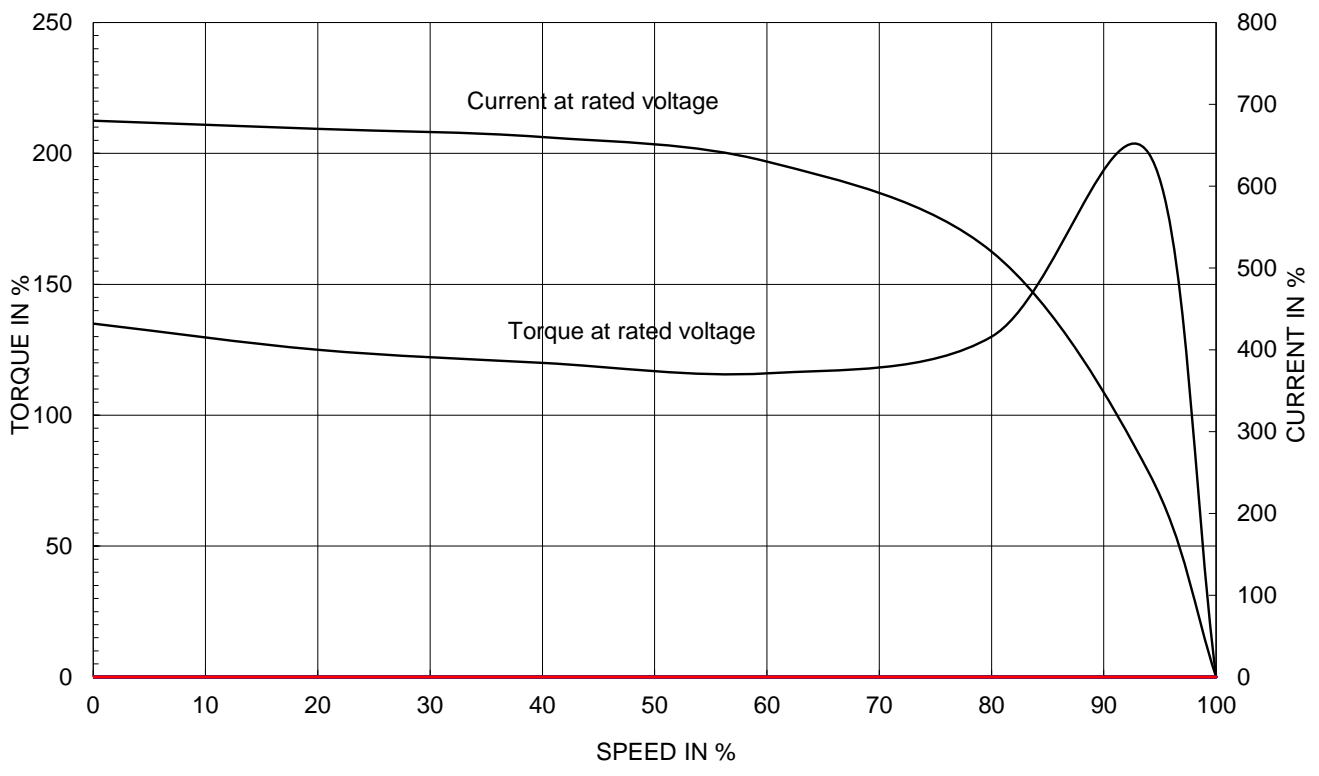

OUTPUT VS EFF., P.F & CURRENT CURVE

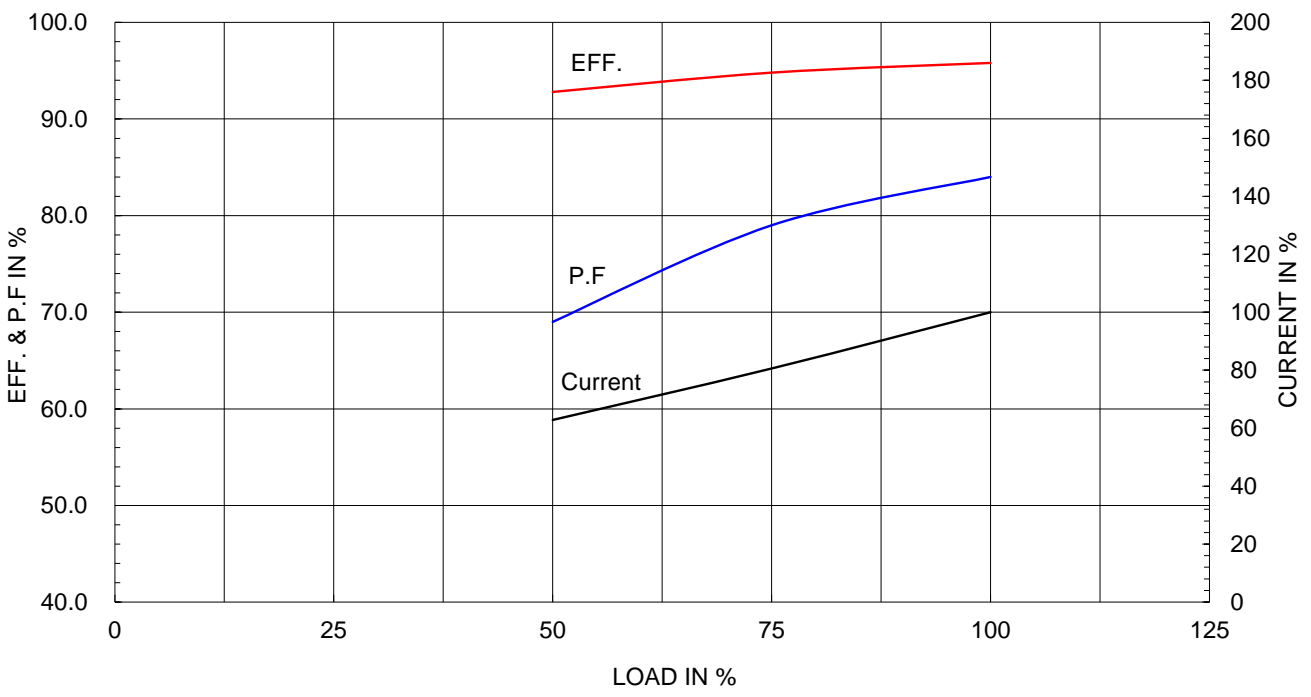

본 도면은 HD현대일렉트릭(주) 재산이며 허가없이 복사할 수 없음 (취급유의)

THIS DRAWING IS PROPRIETARY TO HYUNDAI ELECTRIC. NO PART OF THIS DRAWING MAYBE REPRODUCED WITHOUT THE PERMISSION OF HYUNDAI ELECTRIC.

▽	50S	REV	DATE	CONTENTS	REVD BY	CHKD BY	CHKD BY	APPD BY
▽▽	12.5S							
▽▽▽	3.2S							
▽▽▽▽	0.4S							

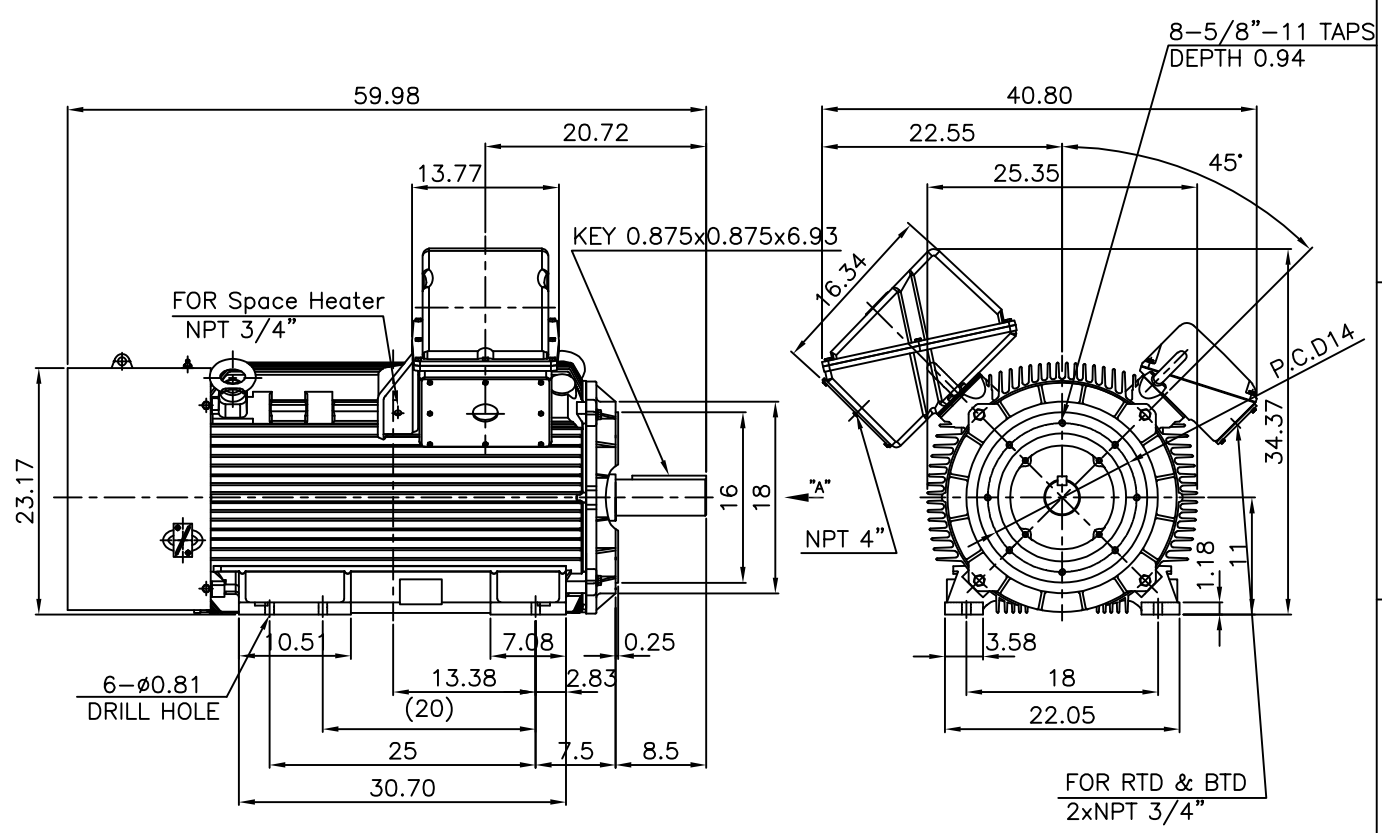

NOTE

1.TOLERANCE :

CENTER HEIGHT	11	+0.000	-0.060
RABBET DIAMETER	ø16	0	-0.005
SHAFT DIAMETER	ø3.375	+0.000	-0.001
KEYWAY WIDTH	0.875	+0.003	-0.000

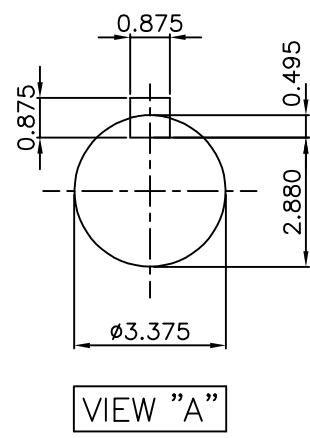

APPD BY	S.Y.KIM	UNIT	INCH	SUBJECT	Fr.L449TC	DWG SIZE	A4 (1:18)
CHKD BY	O.J.KIM	SCALE	1/18	TITLE	OUTLINE		
CHKD BY	R.G.KIM	PROJEC'N	3각법(3rd Angle)	REF. NO		Sheet No.	of
DSND BY	H.K.LEE	DATE	2021-04-27	DWG NO	LM-T044XC4U7001	Revision No.	0

**Cls. I&II, Div. 2
IEEE 841**

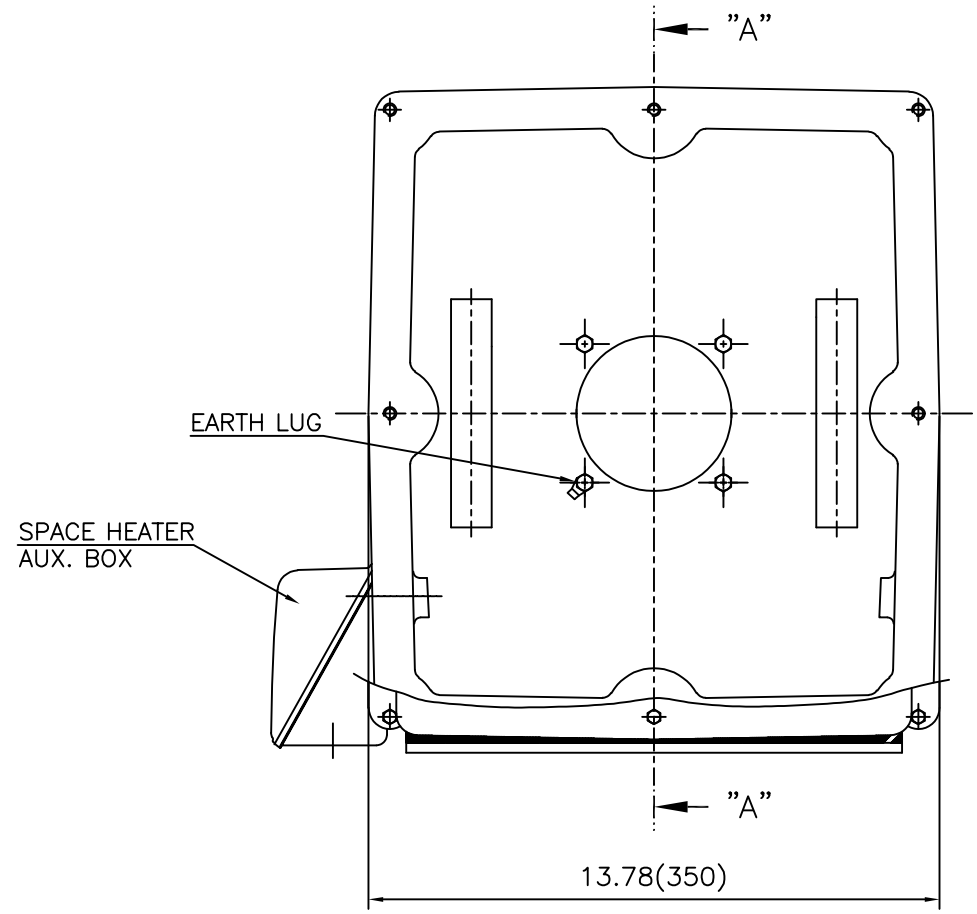

SEC. "A" - "A"

REV	DATE	CONTENTS	REVD BY	CHKD BY	CHKD BY	APPD BY

APPD BY	S.Y.KIM	UNIT	inch(mm)	SUBJECT	FR. L440 (CAST IRON)	DWG SIZE
CHKD BY		SCALE	1/3.5	TITLE	MAIN TERMINAL BOX ASS'Y	A3 (1:3.5)
CHKD BY	R.G.KIM	PROJEC'N	3rd Angle			
DSND BY	최승희	DATE	2023-10-19			
				REF. NO		Sheet No. of
				DWG NO	3M-248452	Revision No. 0

Cls. I&II, Div. 2 IEEE 841

본 도면은 HD현대일렉트릭(주) 재산이며
허가없이 복사할 수 없음 (취급주의)

THIS DRAWING IS PROPRIETARY TO HYUNDAI ELECTRIC. NO PART OF THIS DRAWING
MAY BE REPRODUCED WITHOUT THE PERMISSION OF HYUNDAI ELECTRIC.

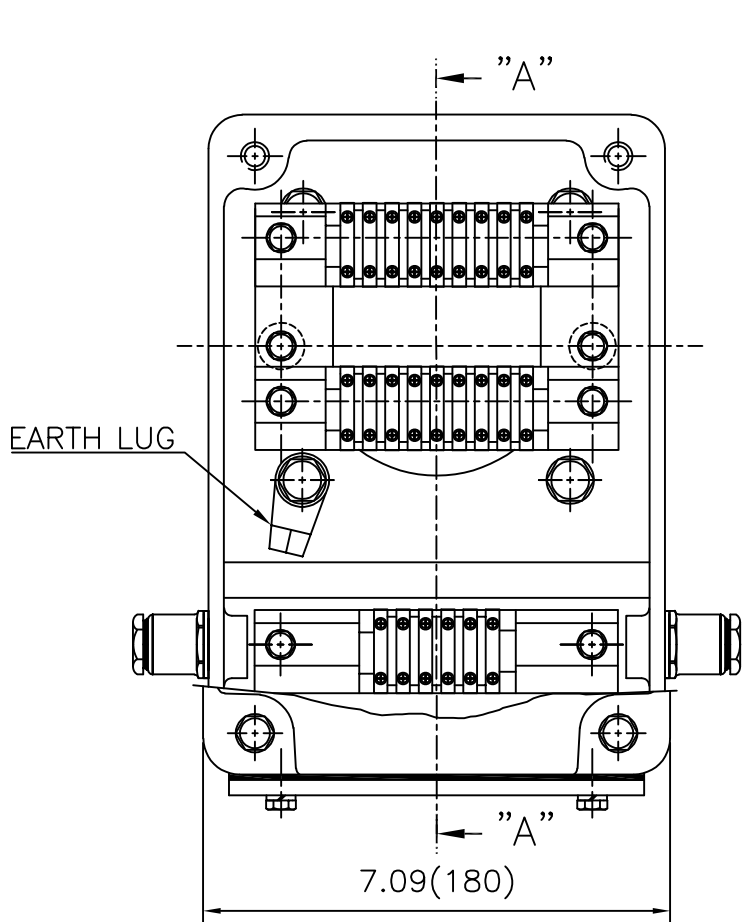

REV	DATE	CONTENTS	REVD BY	CHKD BY	CHKD BY	APPD BY

APPD BY	S.Y.KIM	UNIT	inch(mm)	SUBJECT	FR.360 (CAST IRON)	DWG SIZE	A3 (1:2.2)
CHKD BY		SCALE	1/1	TITLE	AUX. TERMINAL BOX ASS'Y		
CHKD BY	R.G.KIM	PROJEC'N	3rd Angle	REF. NO		Sheet No.	of
DSND BY	박승희	DATE	2024-01-18	DWG NO	3M-165277	Revision No.	0

HD HYUNDAI ELECTRIC

**Cls. I&II, Div. 2
IEEE 841**

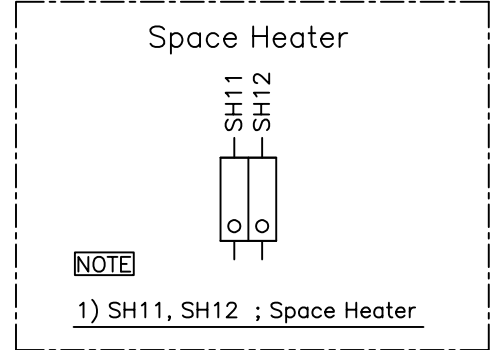
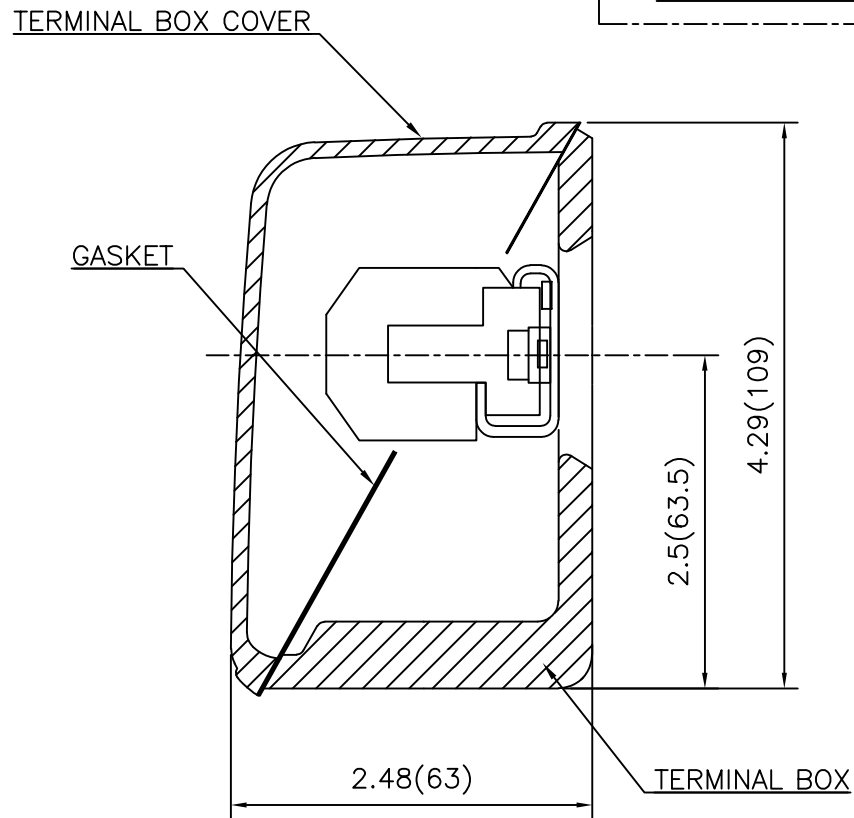

REV	DATE	CONTENTS	REVD BY	CHKD BY	CHKD BY	APPD BY

APPD BY	S.Y.KIM	UNIT	inch(mm)	SUBJECT	FR.180 (CAST IRON)	DWG SIZE
CHKD BY		SCALE	1/1	TITLE	SUB. TERMINAL BOX ASS'Y	A3 (1:1.1)
CHKD BY	R.G.KIM	PROJEC'N	3rd Angle			
DSND BY	배승희	DATE	2024-01-18			
				REF. NO		Sheet No. of
				DWG NO	3M-165277	Revision No. 0