

Customer :
 Project Name :
 Project No. :
 Revision No. :

SPECIFICATION for INDUCTION MOTOR



0		For Bidding			
No.	DATE	DESCRIPTION	PREPARED BY	CHECKED BY	APPROVED BY



AC INDUCTION MOTOR DATA SHEET

IEEE841 TYPE

Catalog No.	IEEE900-36-5812S-IBBRSRSHSP-F	Item No.		Rev. No.	[]
Project Name		Project No.		Quantity	sets

GENERAL SPECIFICATION			PERFORMANCE DATA			
Frame Size	5812S		Rated Output	671 kW 900 HP		
Type	HNE6		Number of Poles	2		
Enclosure(Protection)	Totally Enclosed	/ IP55	Rotor Type	Squirrel Cage		
Method of Cooling	IC411(FC)		Starting Method*	D.O.L		
Rated Frequency	60 Hz		Rated Voltage	575 V	460 V	230 V
Number of Phases	3		Current	Full Load	790.2 A	987.8 A 1,975.5 A
Insulation Class	F			Locked-rotor**	700 %	700 % 700 %
Temp. Rise at full load (by resistance method)			Efficiency			
at 1.0 S.F	95 deg. C		50% Load		92.8 %	
Motor Location	<input type="checkbox"/> Indoor <input type="checkbox"/> Outdoor		75% Load		94.8 %	
Altitude	Less than 1,000 meter		100% Load		95.8 %	
Relative Humidity	Less than 80 %		Power Factor(p.u)			
Ambient Temp.	40 deg. C (Max.)		50% Load		0.740	
Duty Type	Continuous (S1)		75% Load		0.840	
Service Factor	1.15		100% Load		0.890	
Mounting	B3		Speed at Full Load	3570 r.p.m		
Bearing	Type	Anti-Friction	Torque			
	DE/N-DE	6316C3 / 6316C3-INS.	Full Load	1,324.1 lb.ft		
	Lubricant	Grease(Polyrex-EM)	Locked-rotor**	150 %		
External Thrust	Not applicable		Breakdown**	250 %		
Coupling Method	<input checked="" type="checkbox"/> Direct <input type="checkbox"/> V-belt		Moment of Inertia (J)			
Shaft Extension	Single		Load(Max.)	628.154 lb.ft2		
Terminal Box	Main	Steel	Motor	123.500 lb.ft2		
	Aux.	Yes	Sound Pressure Level (No-load & mean value at 1m from motor)			
Location	Refer to Outline Drawing				89 dB(A)	
Application			Vibration			
Area classification	Hazardous				3.8 mm/sec (peak)	
Type of Ex-Protection	Class I, Division 2		Permissible number of consecutive starts		Cold 2 times Hot 1 time	
Applicable Standard	IEEE841, NEMA MG1, CSA C390		Paint	Munsell No.	7.5BG6/1.5	

ACCESSORIES
*. B.T.D.(Pt 100 Ω at 0°C,Single) : 2EA/Motor
*. W.T.D.(Pt 100 Ω at 0°C) : 2EA/Ph.
*. Space Heater : 1EA/Motor

SPARE PARTS
1. Spare Axial Fan (C.W Direction)

SUBMITTAL DRAWING			
Outline Dimension Drawing		Motor Weight(Approx.)	
B3	LM-I5812B3C7001	7130 lb.	

REMARK
1. Premium efficiency according to NEMA MG1
2. Inverter Duty @ 1.0 Service Factor & F Temperature rise -. 10:1 VT -. 2:1 CT
3. NDE side : Insulated bearing
4. CSA Certification -. Class I, Division 2, Group A, B, C & D; Temp code : T3A
5. Shaft material : AISI4140
6. Uni-directional CCW viewed from drive end.

Date	DSND	CHKD	CHKD	APPD
2024-09-22	E.J.LEE	I.K. Kim	R.G. Kim	S.W. Kim

[Note] Others not mentioned in this data sheet shall be in accordance with maker standard.
 Above technical data are only design values and shall be guaranteed with tolerance of applicable standard.
 Inspection and performance test shall be done according to maker standard, if not mentioned.
 * In case of Inverter-Fed Motor, performance data is based on sine wave tests. It may be different from test data of Inverter combined motor.
 ** Data is based on rated voltage & frequency and is expressed as a percentage of full-load value.

본 도면은 HD현대일렉트릭(주) 재산이며
허가없이 복사할 수 없음 (취급주의)

THIS DRAWING IS PROPRIETARY TO HYUNDAI ELECTRIC. NO PART OF THIS DRAWING
MAYBE REPRODUCED WITHOUT THE PERMISSION OF HYUNDAI ELECTRIC.

	REV	DATE	CONTENTS

4.72

CROWN TRITON

Premium Efficiency AC 3 Phase Motor

900HP 2P 460V	Cat. No. IEEE900-36-5812S-IBBRSRSHSP-F
Model LATER	INS. Class F Amps 987.8
Type HNE6 Duty CONT	Code G Amb. 40°C Hertz 60Hz
Frame 5812S Encl. TEFC	S.F. 1.15 RPM 3570 NEMA Norm. Eff. 95.8%
Bearing	Drive 6316C3 S.F.1.00 (2:1 C.T., 10:1 V.T., NEMA-MG1 Part31) 3/4 Eff. 94.8%
	Opp. 6316C3-INS. NEMA Design B Torque
Usable at	50Hz 750HP 380V 997.9A 2970rpm S.F.: 1.0 Eff.: 95.8% Code: G
	50Hz 750HP 400/415V 969.8/945.52A 2972/2975rpm S.F.: 1.0 Eff.: 95.8/95.81% Code: H/H
CSA Certified for	CLASS I, Div. 2, Gr. A, B, C & D Temp. Code (sine wave) Frame 580FR
	Maximum Amb. 50°C T3A (180°C)
No. -	Date - Weight 7130 lb

IEEE Std 841-2021 4M-136445

Made in Korea H1

APPD BY	S.Y.KIM	UNIT	INCH
CHKD BY	I.K.KIM	SCALE	NONE
CHKD BY	R.G.KIM	PROJEC'N	3rd Angle
DSND BY	S.H.LEE	DATE	2024.06.07

SUBJECT	CSA Class I, Division2 IEEE841 (XL)	DWG SIZE	A4 (1:1)
TITLE	NAMEPLATE DRAWING		
REF. NO	4M-136445	Sheet No.	of
DWG NO	NP-IEEE900-36-5812S-IBBRSRSHSP-F	Revision No.	0



PERFORMANCE CURVE

CURVE NO.

PC-IEEE900-36-5812S-IBBRSRSHSP-F

Type :	HNE6
Full Load Torque :	1324.1 lb.ft
Load moment of Inertia (J) :	628.154 lb.ft2
Motor moment of Inertia (J) :	123.500 lb.ft2

671kW 900HP	2 P	60 Hz
Speed at Full Load :		3570 RPM
Rated Voltage	575V	460V 230V
Full Load Current	790.2A	987.8A 1975.5A

SPEED VS TORQUE & CURRENT CURVE

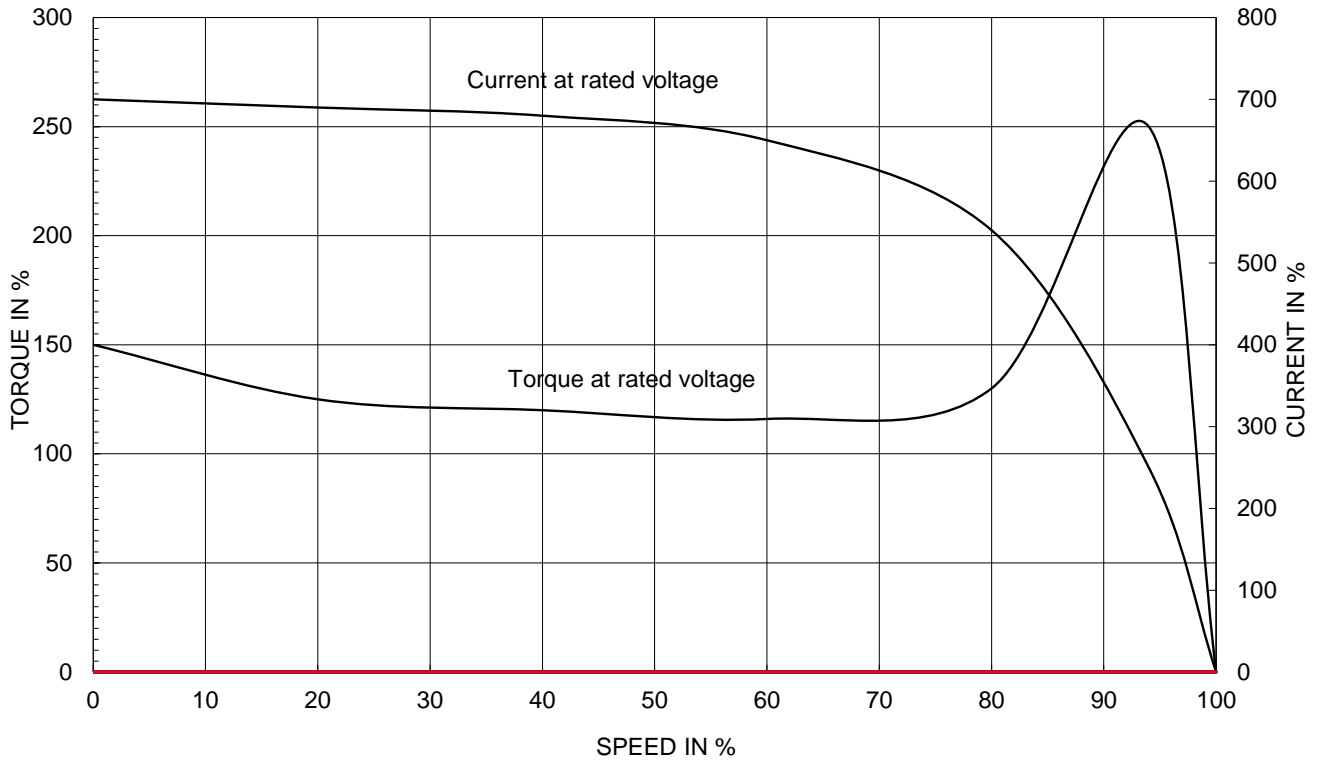

OUTPUT VS EFF., P.F & CURRENT CURVE

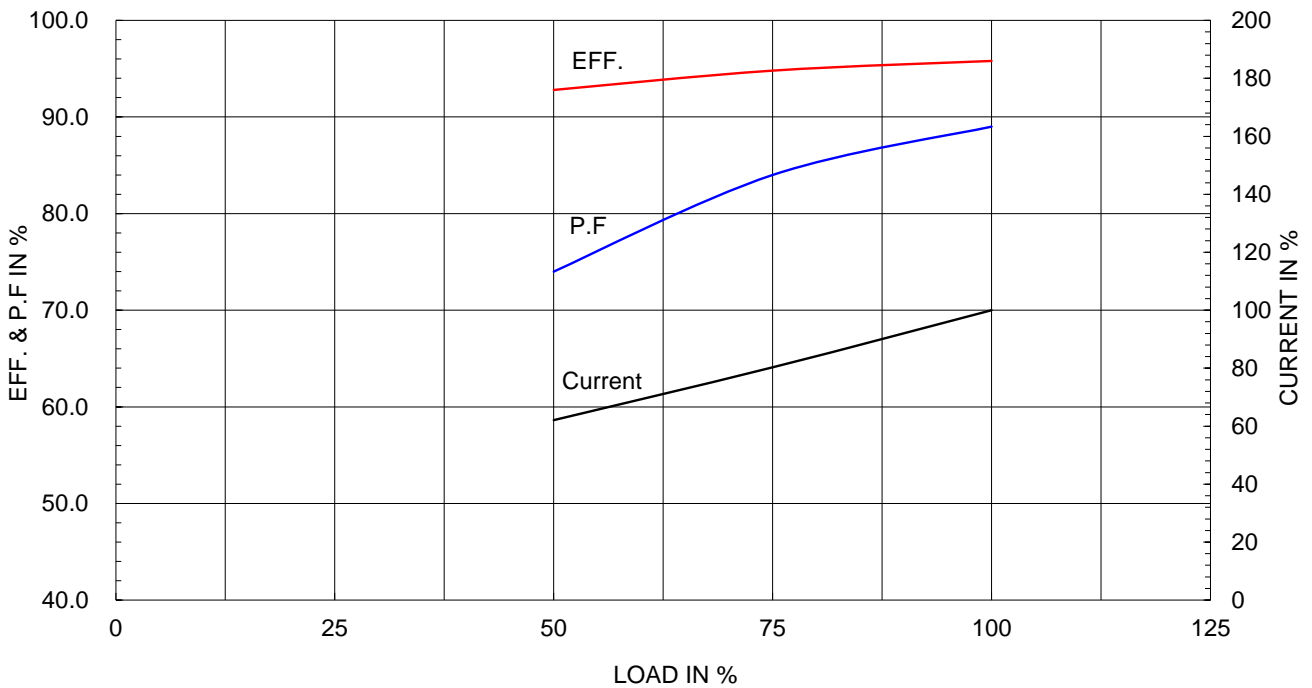

THIS DRAWING IS PROPRIETARY TO HYUNDAI ELECTRIC. NO PART OF THIS DRAWING MAY BE REPRODUCED WITHOUT THE PERMISSION OF HYUNDAI ELECTRIC.

본 도면은 HD현대일렉트릭(주) 재산이며 허가없이 복사할 수 없음 (취급주의)

IEEE841

APPROX.82.04"(2084)

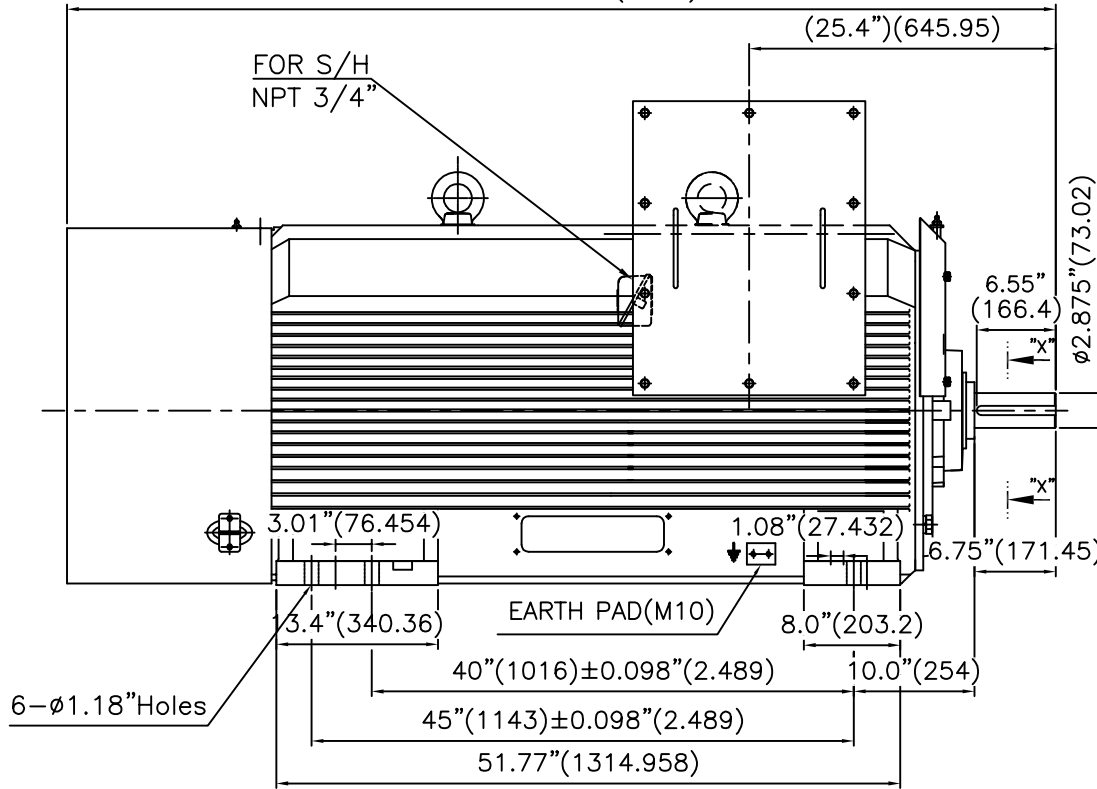

TECHNICAL INFORMATION

1) BEARING & LUBRICANT LIST

BEARING	Drive End	Non-Drive End
Bearing Type	6316C3	6316C3
Lubricant Type	GREASE	GREASE
Grease Type	Mobil(Polyrex-EM)	Mobil(Polyrex-EM)
Initial Charge Quantity	200 g	200 g
Mark-Up	Quantity	33 g
	Interval	2 MONTHS

2) TOLERANCE :

CENTER HEIGHT	14.5	+0.000	-0.060
SHAFT DIAMETER	2.875	+0.000	-0.001
KEYWAY WIDTH	0.75	+0.003	-0.000

APPROX.51.87"(1318)

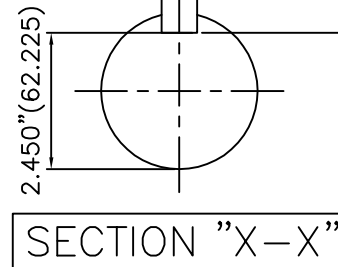
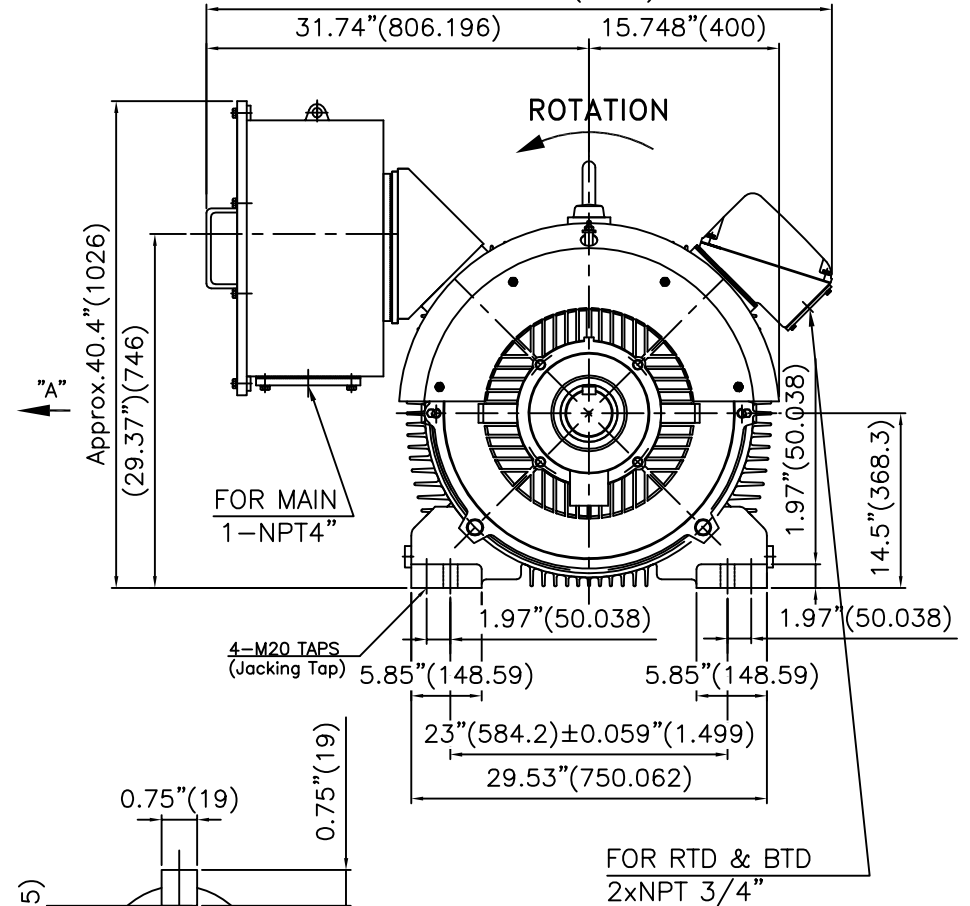

VIEW "A"

Q'TY	DESCRIPTION	MATERIAL	DIMENSION	WEIGHT	PART NO.	REMARK
APPD BY	S.K.HAN	UNIT	INCH(MM)	SUBJECT	Fr.5812-2P	
CHKD BY	S.Y.KIM	SCALE	1/12	TITLE	OUTLINE	
CHKD BY	R.G.KIM	PROJEC'N	3각법 (3rd Angle)	REF. NO		Sheet No. of
DSND BY	M.S.HA	DATE	2019.05.16	DWG NO	LM-I5812B3C7001	Revision No.

REV	DATE	CONTENTS	REVD BY	CHKD BY	CHKD BY	APPD BY
1						
2						
3						
4						



**Cls. I&II, Div. 2
IEEE 841**

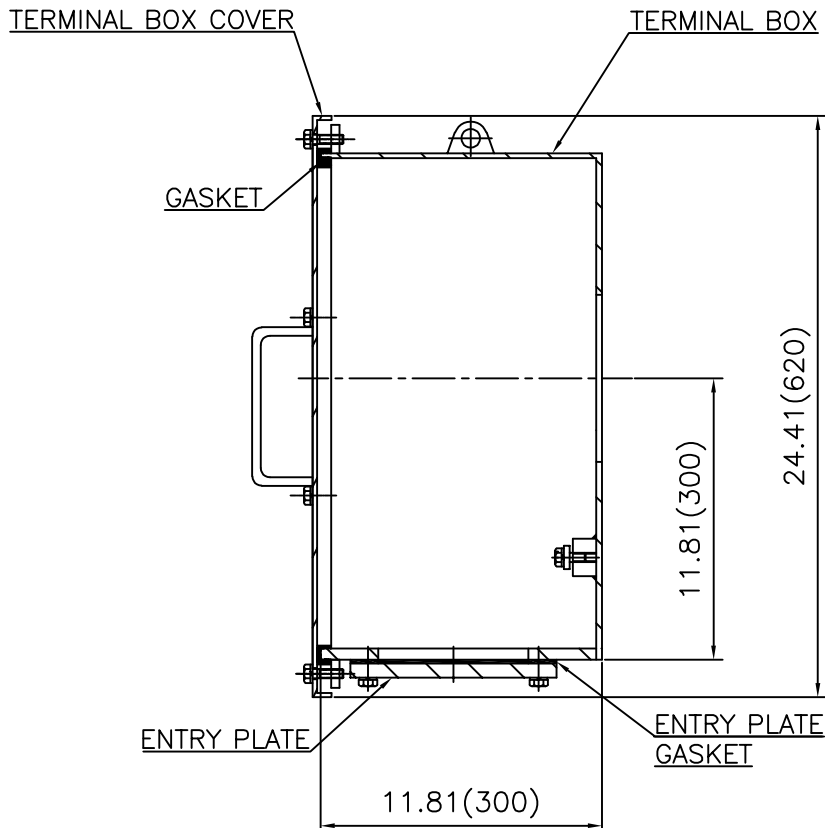
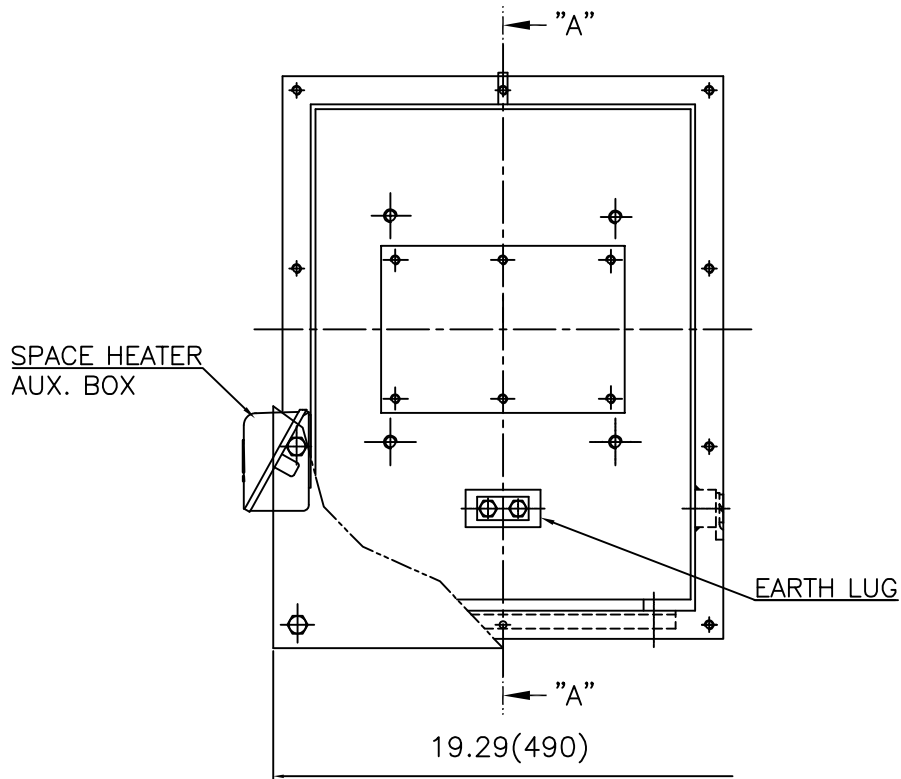

SEC. "A" - "A"

REV	DATE	CONTENTS	REVD BY	CHKD BY	CHKD BY	APPD BY
1						
2						
3						
4						

APPD BY	S.Y.KIM	UNIT	inch(mm)	SUBJECT	FR.580 (STEEL)	DWG SIZE	A3 (1:6)
CHKD BY		SCALE	1/6	TITLE	MAIN TERMINAL BOX ASS'Y		
CHKD BY	R.G.KIM	PROJEC'N	3rd Angle	REF. NO		Sheet No.	of
DSND BY	배승희	DATE	2023-10-25	DWG NO	3M-248512	Revision No.	0



**Cls. I&II, Div. 2
IEEE 841**

본 도면은 HD현대일렉트릭(주) 재산이며
허가없이 복사할 수 없음 (취급주의)

THIS DRAWING IS PROPRIETARY TO HYUNDAI ELECTRIC. NO PART OF THIS DRAWING
MAY BE REPRODUCED WITHOUT THE PERMISSION OF HYUNDAI ELECTRIC.



REV	DATE	CONTENTS	REVD BY	CHKD BY	CHKD BY	APPD BY

APPD BY	S.Y.KIM	UNIT	inch(mm)	SUBJECT	FR.360 (CAST IRON)	DWG SIZE	A3 (1:2.2)
CHKD BY		SCALE	1/1	TITLE	AUX. TERMINAL BOX ASS'Y	REF. NO	Sheet No. of
CHKD BY	R.G.KIM	PROJEC'N	3rd Angle	DSND BY		네슬렉	DATE
				DWG NO	3M-165277	Revision No. 0	

**Cls. I&II, Div. 2
IEEE 841**

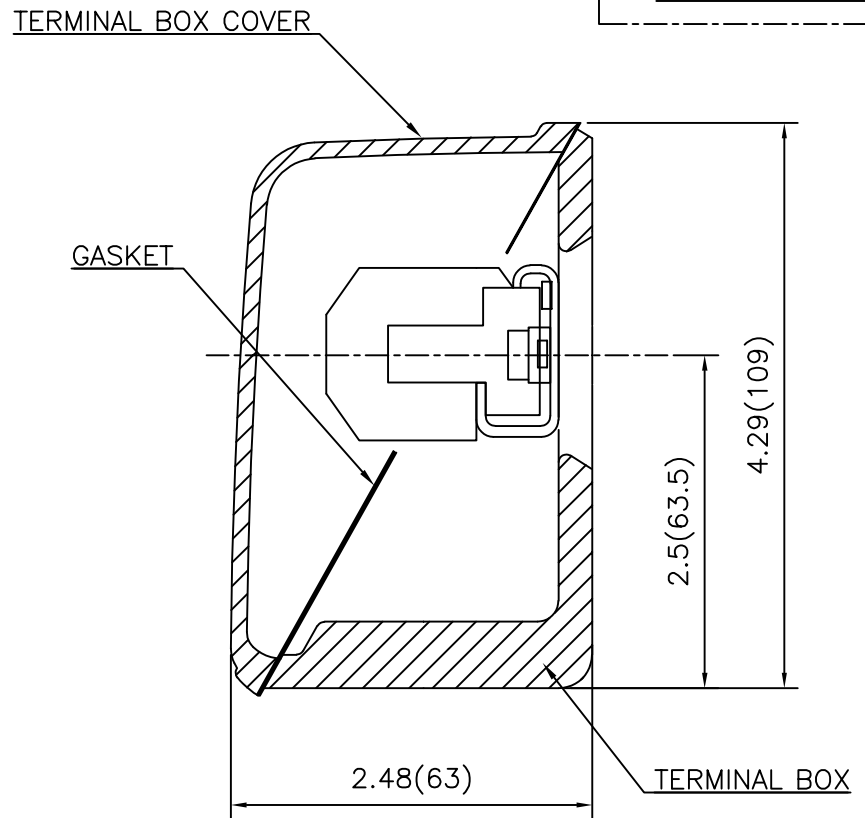
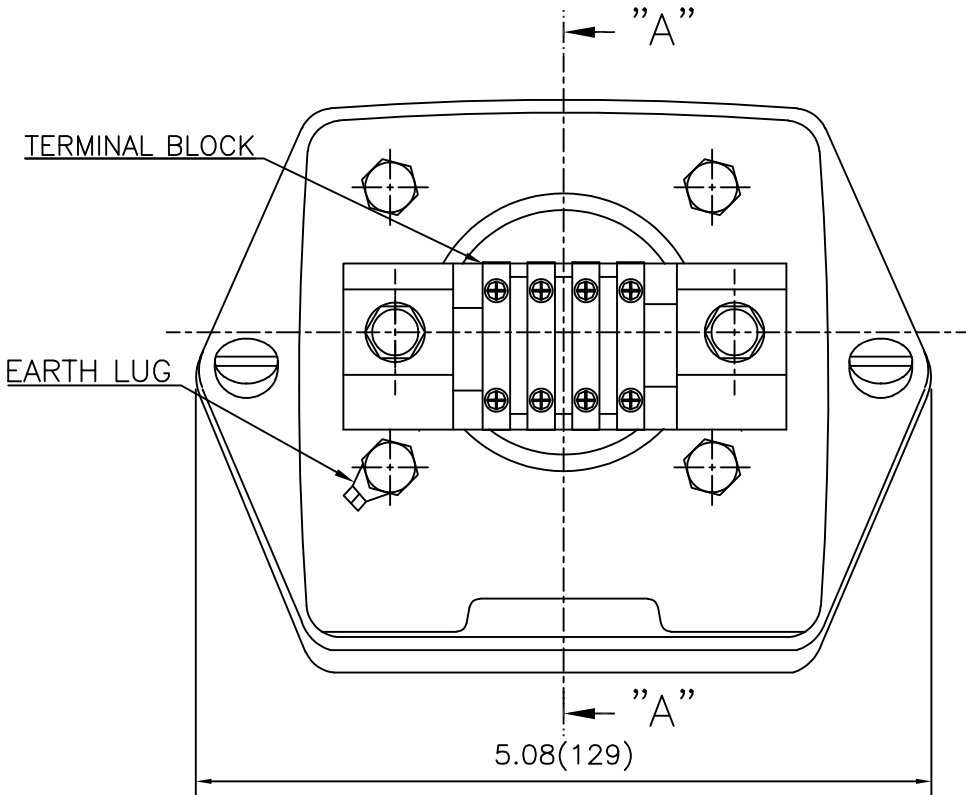

SEC. "A" - "A"

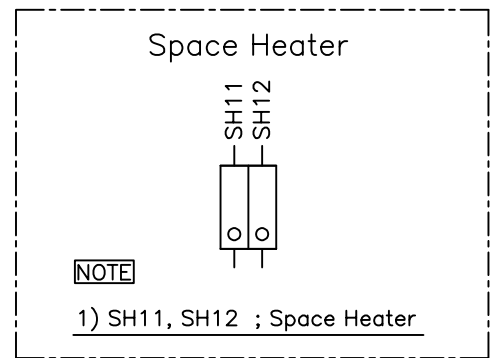

REV	DATE	CONTENTS	REVD BY	CHKD BY	CHKD BY	APPD BY

APPD BY	S.Y.KIM	UNIT	inch(mm)	SUBJECT	FR.180 (CAST IRON)	DWG SIZE
CHKD BY		SCALE	1/1	TITLE	SUB. TERMINAL BOX ASS'Y	A3 (1:1.1)
CHKD BY	R.G.KIM	PROJEC'N	3rd Angle			
DSND BY	배승희	DATE	2024-01-18			
				REF. NO		Sheet No. of
				DWG NO	3M-165278	Revision No. 0