

Customer :
Project Name :
Project No. :
Revision No. :

SPECIFICATION for INDUCTION MOTOR



0		For Bidding			
No.	DATE	DESCRIPTION	PREPARED BY	CHECKED BY	APPROVED BY



AC INDUCTION MOTOR DATA SHEET

Explosion Proof type

Catalog No.	IXHHI15-18-254T	Item No.		Rev. No.	[]
Project Name		Project No.		Quantity	sets

GENERAL SPECIFICATION			PERFORMANCE DATA			
Frame Size	254T		Rated Output	11 kW		15 HP
Type	XJP		Number of Poles	4		
Enclosure(Protection)	Totally Enclosed	/ IP55	Rotor Type	Squirrel Cage		
Method of Cooling	IC411(FC)		Starting Method*	D.O.L		
Rated Frequency	60 Hz		Rated Voltage	575 V	460 V	230 V
Number of Phases	3		Current	Full Load	14.6 A	18.2 A
Insulation Class	F			Locked-rotor**	750 %	750 %
Temp. Rise at full load (by resistance method)			Efficiency			
at 1.0 S.F	80 deg. C		50% Load		89.4 %	
Motor Location	<input type="checkbox"/> Indoor <input type="checkbox"/> Outdoor		75% Load		91.4 %	
Altitude	Less than 1,000 meter		100% Load		92.4 %	
Relative Humidity	Less than 80 %		Power Factor(p.u)			
Ambient Temp.	40 deg. C (Max.)		50% Load		0.670	
Duty Type	Continuous (S1)		75% Load		0.770	
Service Factor	1.15		100% Load		0.820	
Mounting	B3		Speed at Full Load	1775 r.p.m		
Bearing	Type	Anti-Friction	Torque			
	DE/N-DE	6309ZC3 / 6309ZC3	Full Load	43.7 lb.ft		
	Lubricant	Grease(Polyrex-EM)	Locked-rotor**	200 %		
External Thrust	Not applicable		Breakdown**	240 %		
Coupling Method	<input checked="" type="checkbox"/> Direct <input type="checkbox"/> V-belt		Moment of Inertia (J)			
Shaft Extension	Single		Load(Max.)	88.098 lb.ft2		
Terminal Box	Main	Cast Iron	Motor	2.136 lb.ft2		
	Aux.	No	Sound Pressure Level (No-load & mean value at 1m from motor)			
Location	Refer to Outline Drawing				74 dB(A)	
Application			Vibration			
Area classification	Hazardous				0.0 mm/sec (peak)	
Type of Ex-Protection	Class I&II, Division 1		Permissible number of consecutive starts	Cold	0 times	
Applicable Standard	NEMA MG1, CSA C390, UL674		Hot	0 times		
			Paint	Munsell No.	4.0PB5.4/5.5(VL-451)	

ACCESSORIES

*. W.T.D.(Thermostat, 145°C) : 1EA/Ph.

SPARE PARTS

SUBMITTAL DRAWING

Outline Dimension Drawing		Motor Weight(Approx.)	
B3	LM-U0254B3TL001	310 lb.	

REMARK

- Premium efficiency according to NEMA MG1
- Inverter Duty @ 1.0 Service Factor & Ambient max 45°C
 - 4:1 CT (10:1 CT at 1hour Duty)
 - 10:1 VT (20:1 VT at 50% load)
 - CHP up to 1.5 times base speed, NEMA MG1 Part31
- Class I, Division 1, Group C&D
 - Temp.Code(Sine wave) : T2D at 40°C Amb./T2C at 55°C Amb. T4 with Winding Temperature Detector
- Class II, Division 1, Group F&G
 - Temp.Code(Sine wave) : T3B

Date	DSND	CHKD	CHKD	APPD
2024-08-08	S.H. Lee	I.K. Kim	R.G. Kim	S.W. Kim

[Note] Others not mentioned in this data sheet shall be in accordance with maker standard.
 Above technical data are only design values and shall be guaranteed with tolerance of applicable standard.
 Inspection and performance test shall be done according to maker standard, if not mentioned.
 * In case of Inverter-Fed Motor, performance data is based on sine wave tests. It may be different from test data of Inverter combined motor.
 ** Data is based on rated voltage & frequency and is expressed as a percentage of full-load value.

1	2	3	4
REV	DATE	CONTENTS	REVD BY

4.72

CROWN TRITON
Premium Efficiency AC 3 Phase Motor

Explosion Proof









15HP	4P	230/460V	Cat. No. IXHHI15-18-254T	Amps	36.4/18.2
Model	LATER		INS. Class F HD-F1	Hertz	60Hz
Type	XJP	Duty	CONT	Code	J
Frame	254T	Encl.	TEFC	S.F. 1.15	on sine wave power
Bearing	Drive	6309ZC3	S.F. 1.00	on PWM or IGBT power	NEMA Design
	Opp.	6309ZC3	RPM	1775	Amb.
Usable at	50Hz 10HP 380V 18A 1475rpm S.F.: 1.0 Eff.: 88.7% Code: L				
	50Hz 10HP 400/415V 17.9/18.1A 1480/1480rpm S.F.: 1.0 Eff.: 88.7/88.7% Code: L/L				
UL Certified for	Class I, Div. 1, Group C&D / Class I, Zone 1, Group II A & II B			Temp. Code	T2D at 40°C Amb. / T2C at 55°C Amb.
	10:1VT(20:1 at 50% load) 4:1CT(10:1 1hour duty at lowest RPM)				T4 With Thermostat
No.	-		Date	-	
			Weight	310 lb	

4M-136066
(NEMA 250~280Fr.)

Made in Korea H1



2.36

APPD BY	S.Y.KIM	UNIT	INCH	SUBJECT	UL Class I, Division1 (IXHHI)	DWG SIZE
CHKD BY	I.K.KIM	SCALE	NONE			A4 (1:1)
CHKD BY	R.G.KIM	PROJEC'N	3rd Angle	TITLE NAMEPLATE DRAWING		
DSND BY	S.H.LEE	DATE	2024.06.07			
				REF. NO	4M-136066	Sheet No. of
				DWG NO	NP-IXHHI15-18-254T	Revision No. 0



PERFORMANCE CURVE

CURVE NO.

PC-IXHHI15-18-254T

Type :	XJP
Full Load Torque :	43.7 lb.ft
Load moment of Inertia (J) :	88.098 lb.ft2
Motor moment of Inertia (J) :	2.136 lb.ft2

11kW 15HP	4 P	60 Hz
Speed at Full Load :		1775 RPM
Rated Voltage	575V	460V 230V
Full Load Current	14.6A	18.2A 36.4A

SPEED VS TORQUE & CURRENT CURVE

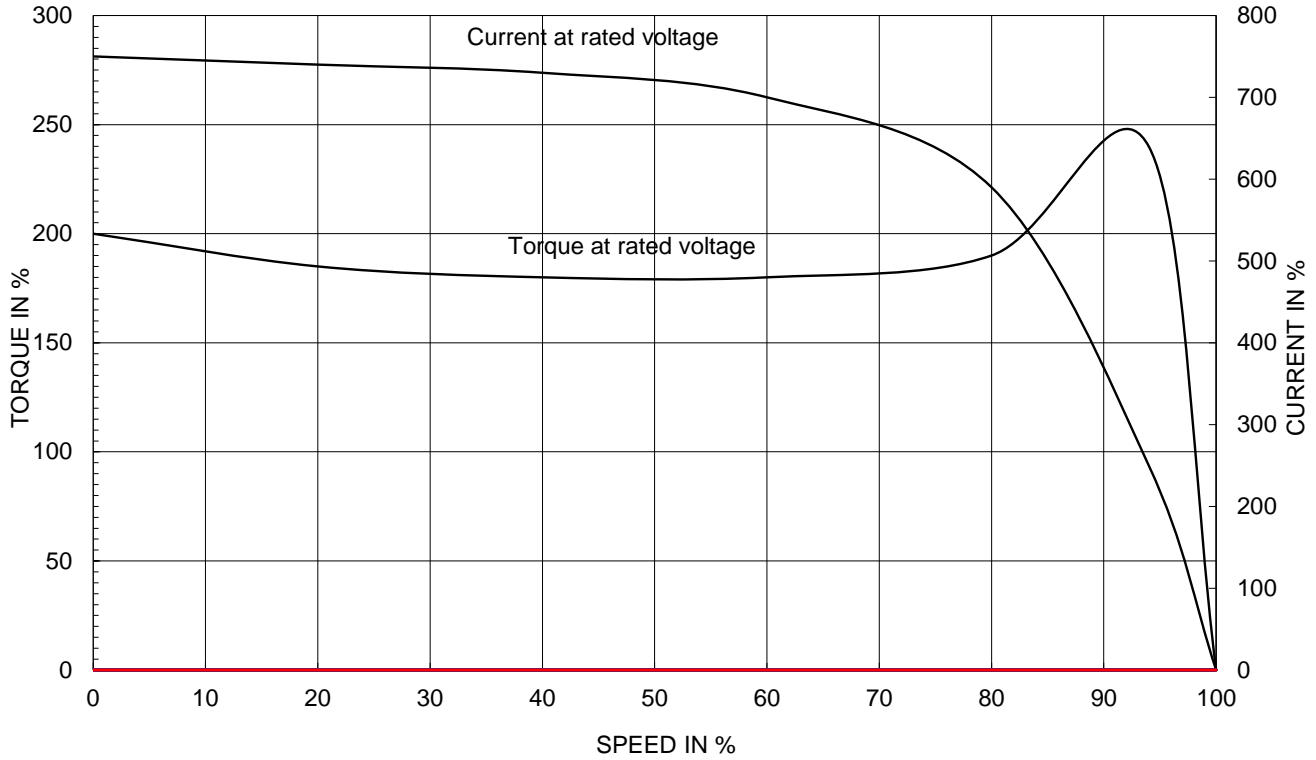

OUTPUT VS EFF., P.F & CURRENT CURVE

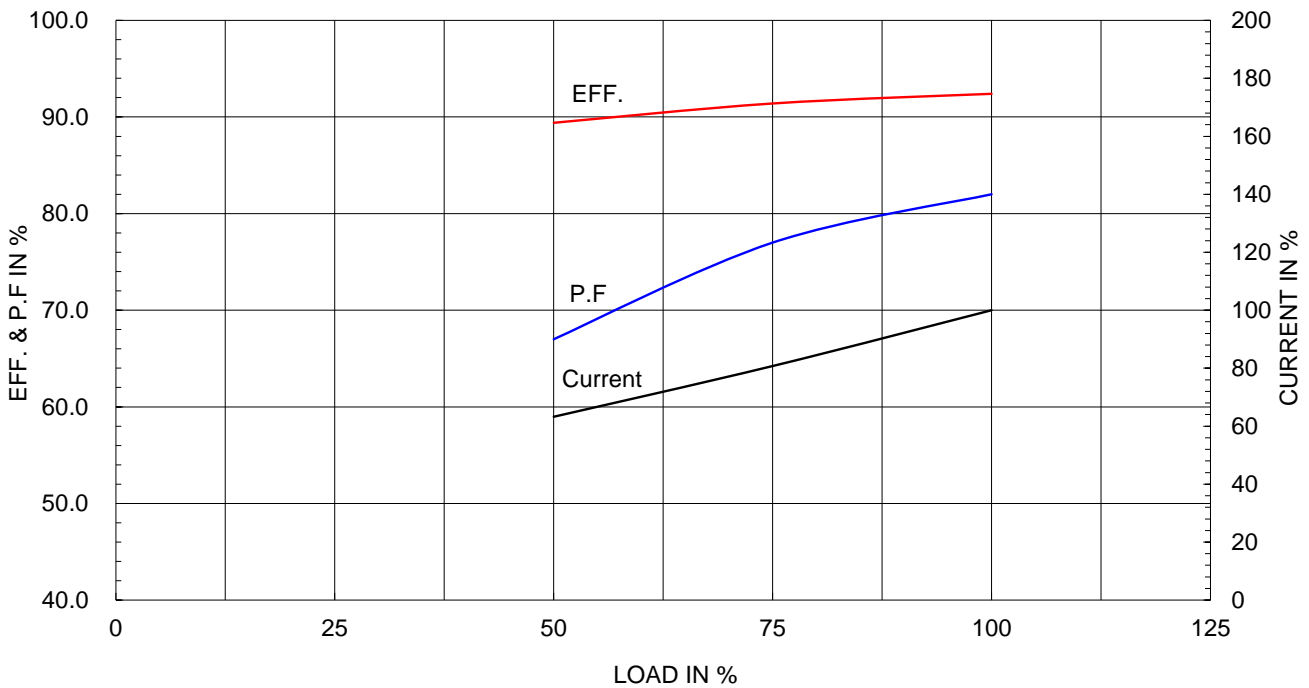

본 도면은 HD현대일렉트릭(주) 재산이며 허가없이 복사할 수 없음 (취급주의)

THIS DRAWING IS PROPRIETARY TO HYUNDAI ELECTRIC. NO PART OF THIS DRAWING MAY BE REPRODUCED WITHOUT THE PERMISSION OF HYUNDAI ELECTRIC.

▽	50S	REV	DATE	CONTENTS	REVD BY	CHKD BY	CHKD BY	APPD BY
▽▽	12.5S							
▽▽▽	3.2S							
▽▽▽▽	0.4S							

Class I Division 1

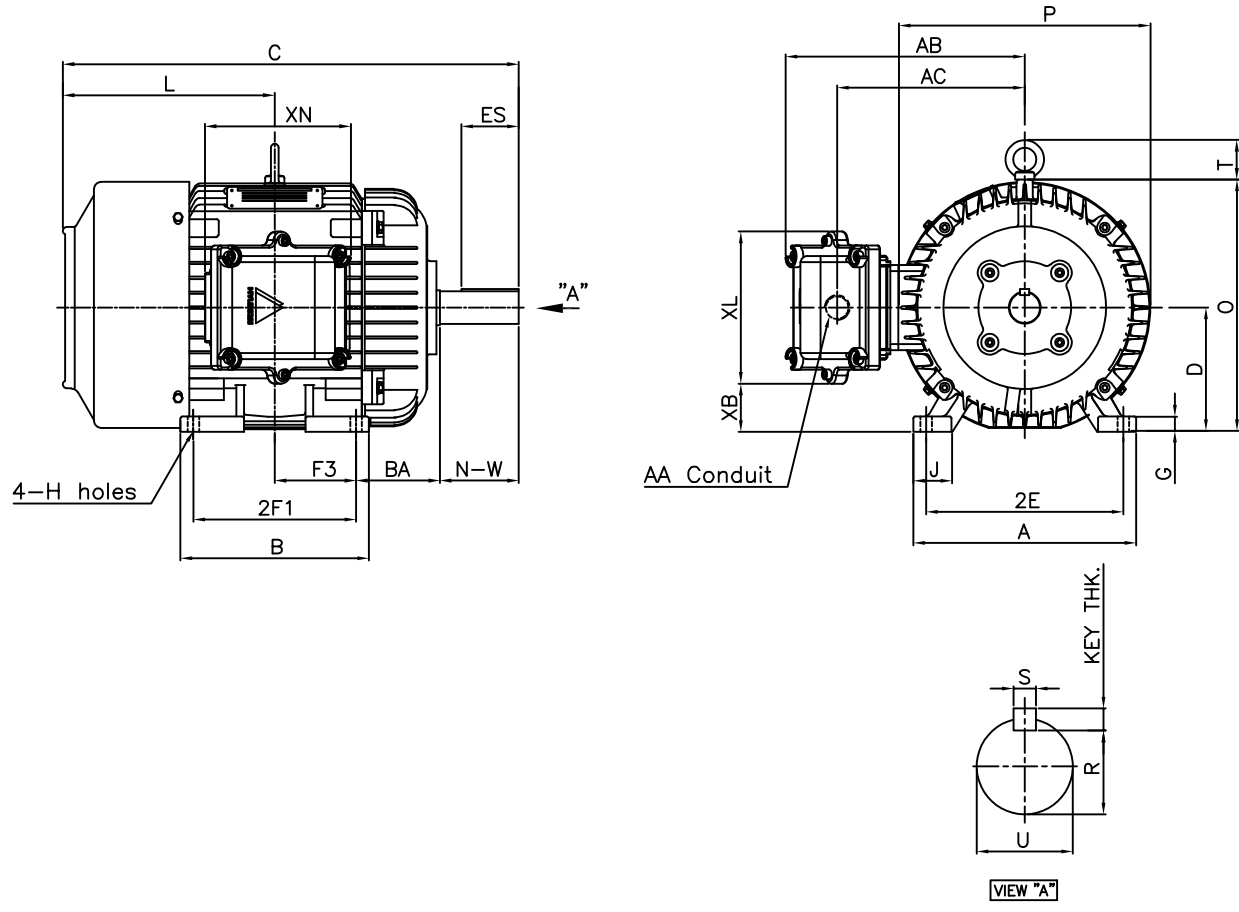

DIMENSIONS

M O U N T I N G									C O N D U I T B O X						APPROX. WGT.(LB)
A	B	2E	2F1	2F2	F3	G	J	H	AA	AB	AC	XB	XL	XN	
11.30	9.56	10.00	8.25	-	4.13	0.72	1.93	0.53	1.25	12.01	9.51	2.39	7.72	7.32	310

O V E R A L L						S H A F T						KEY THK.	B E A R I N G	
BA	C	D	L	O	P	T	U	N-W	KEYWAY				DRIVE END	OPP. DRIVE END
									R	ES	S			
4.25	23.13	6.25	10.75	12.75	12.76	2.01	1.625	4.00	1.416	2.91	0.375	0.375	6309ZC3	6309ZC3

NOTE

- Dimension "D" tolerance : +0.00inch - 0.03inch (143T-365T) ; +0.000inch - 0.06inch (404T-449T)
- Dimension "U" tolerance : +0.000inch - 0.005inch (143T-215T), +0.000inch - 0.001inch (254T-449T)
- Dimension "R" tolerance : +0.000inch - 0.015inch

APPD BY	S.Y.KIM	UNIT	inch	SUBJECT	NEMA 254T	DWG SIZE	A4 (1:10)
CHKD BY	R.G.KIM	SCALE	1/10	TITLE	OUTLINE	Sheet No. of	
CHKD BY		PROJEC'N	3rd Angle			Revision No. 0	
DSND BY	J.H.JEON	DATE	2021-04-15			REF. NO	



Cls. I Div. 1

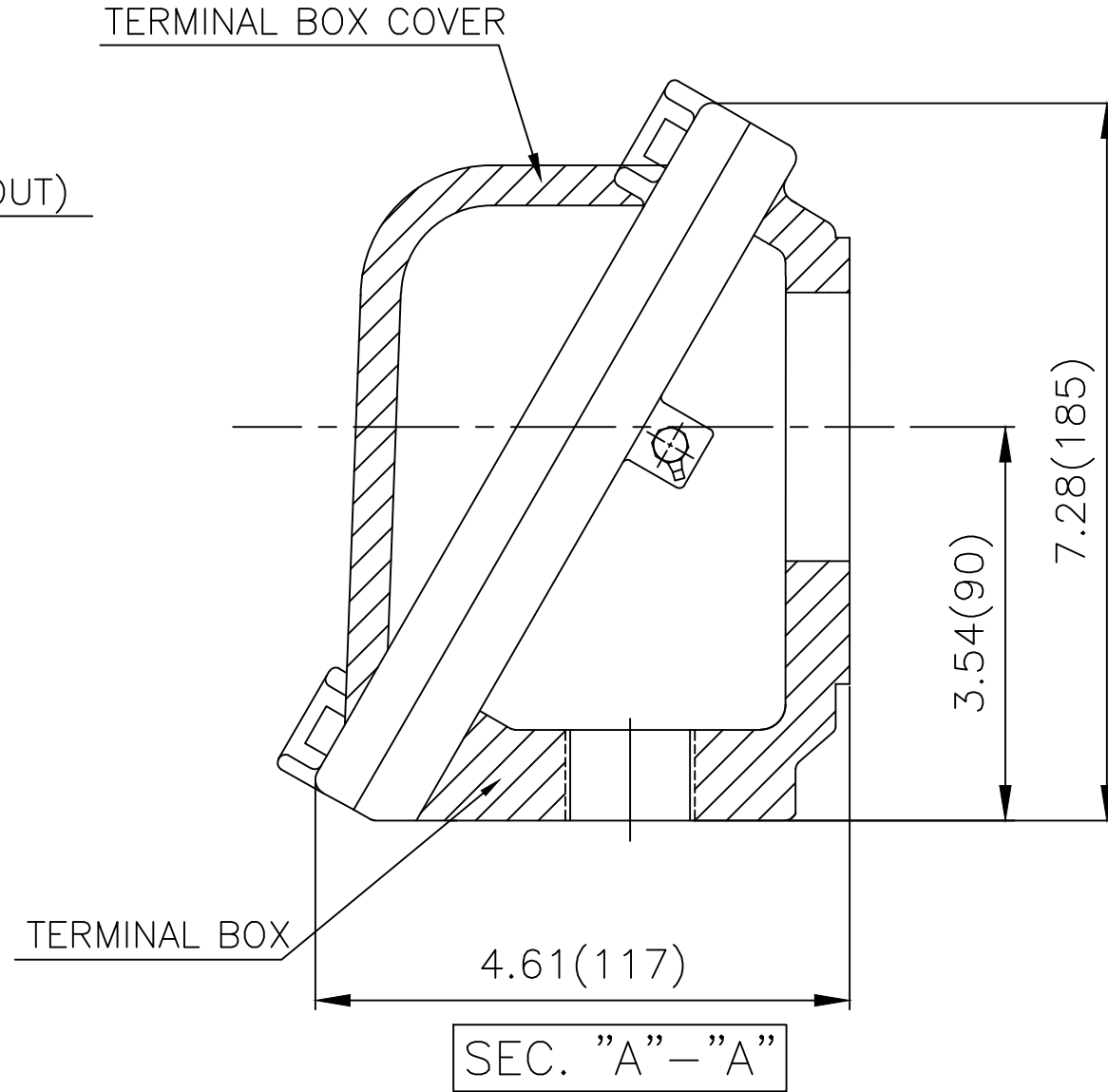
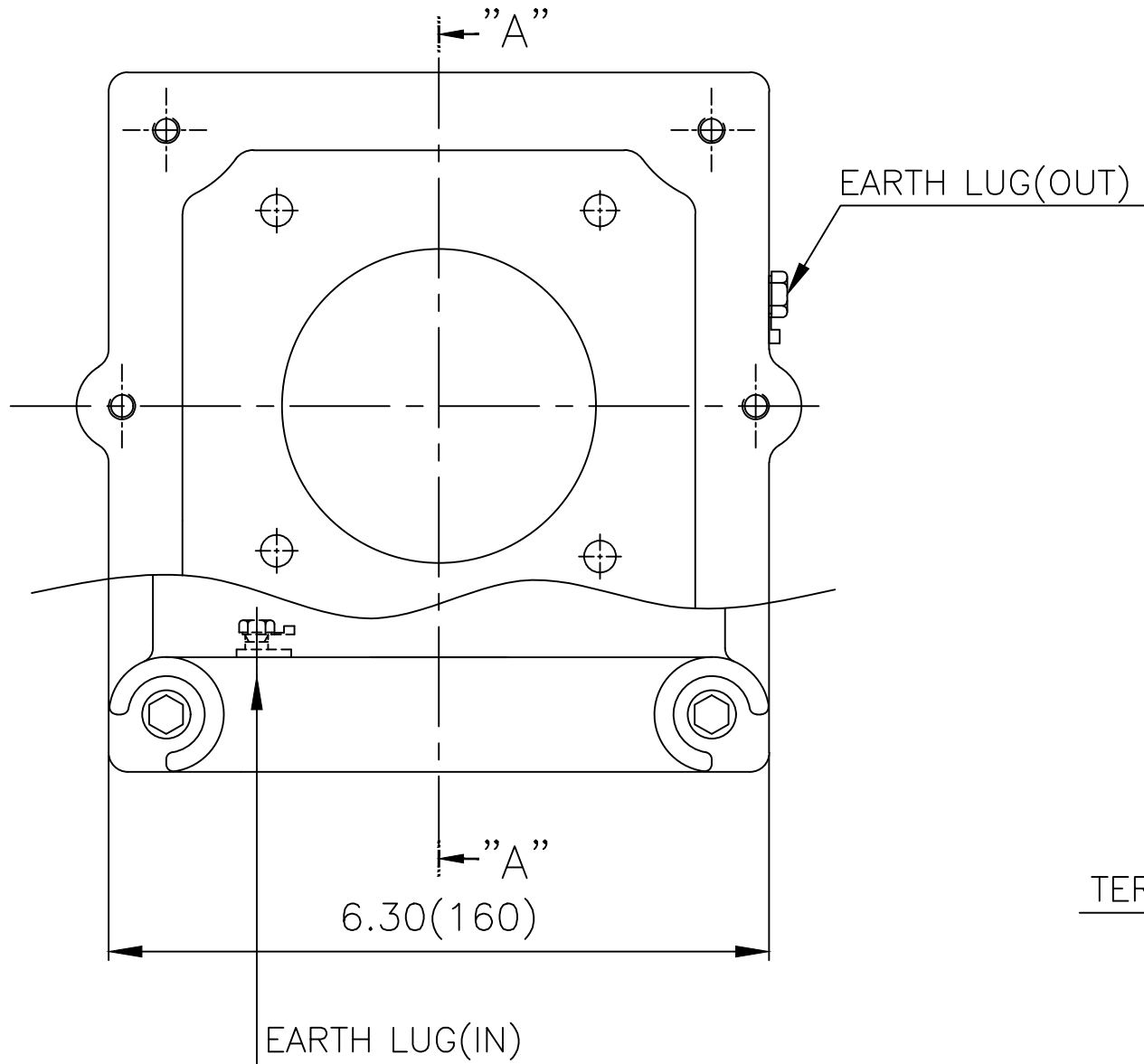

▽	50S
▽▽	12.5S
▽▽▽	3.2S
▽▽▽▽	0.4S

REV	DATE	CONTENTS	REVD BY	CHKD BY	CHKD BY	APPD BY

일반가공공차		일반제관공차	
1-4	±0.1	6-30	±0.5
4-18	±0.2	30-120	±0.8
18-63	±0.3	120-315	±1.2
63-250	±0.5	315-1000	±2.0
250-	±0.8	1000-	±3.0

Q'TY	DESCRIPTION	MATERIAL	DIMENSION	WEIGHT	PART NO.	REMARK	NO.
APPD BY	S.Y.KIM	UNIT	inch(mm)	SUBJECT	NEMA FR. 250~280(CAST IRON)		DWG SIZE
CHKD BY	R.G.KIM	SCALE	1/1.5	TITLE	MAIN TERMINAL BOX ASS'Y		A3 (1:1.5)
CHKD BY		PROJEC'N	3rd Angle	REF. NO		Sheet No.	of
DSND BY	김은진	DATE	2023-11-08	DWG NO	3M-248637	Revision No.	0

