

Customer :
 Project Name :
 Project No. :
 Revision No. :

SPECIFICATION for INDUCTION MOTOR



0		For Bidding			
No.	DATE	DESCRIPTION	PREPARED BY	CHECKED BY	APPROVED BY



AC INDUCTION MOTOR DATA SHEET

Catalog No.	HSDE450-36-5009SC-IBBRSRSHSP	Item No.	Rev. No.	[]
Project Name		Project No.	Quantity	sets

GENERAL SPECIFICATION		PERFORMANCE DATA			
Frame Size	5009SC	Rated Output	335 kW 450 HP		
Type	PJP	Number of Poles	2		
Enclosure(Protection)	Totally Enclosed / IP55	Rotor Type	Squirrel Cage		
Method of Cooling	IC411(FC)	Starting Method*	D.O.L		
Rated Frequency	60 Hz	Rated Voltage	575 V	460 V	230 V
Number of Phases	3	Current	Full Load	390.1 A	487.7 A
Insulation Class	F		Locked-rotor**	725 %	725 %
Temp. Rise at full load (by resistance method)		Efficiency			
at 1.0 S.F	80 deg. C	50% Load		92.8 %	
Motor Location	<input type="checkbox"/> Indoor <input type="checkbox"/> Outdoor	75% Load		94.8 %	
Altitude	Less than 1,000 meter	100% Load		95.8 %	
Relative Humidity	Less than 80 %	Power Factor(p.u)			
Ambient Temp.	40 deg. C (Max.)	50% Load		0.750	
Duty Type	Continuous (S1)	75% Load		0.850	
Service Factor	1.15	100% Load		0.900	
Mounting	B35	Speed at Full Load	3570 r.p.m		
Bearing	Type	Anti-Friction	Torque		
	DE/N-DE	6315C3 / 6315C3-INS.	Full Load	661.1 lb.ft	
	Lubricant	Grease(Polyrex-EM)	Locked-rotor**	130 %	
External Thrust	Not applicable	Breakdown**	230 %		
Coupling Method	<input checked="" type="checkbox"/> Direct <input type="checkbox"/> V-belt	Moment of Inertia (J)			
Shaft Extension	Single	Load(Max.)	349.000 lb.ft2		
Terminal Box	Main	Cast Iron	Motor	70.485 lb.ft2	
	Aux.	Yes	Sound Pressure Level (No-load & mean value at 1m from motor)		
Location	Refer to Outline Drawing	87 dB(A)			
Application		Vibration			
Area classification	Hazardous	3.8 mm/sec (peak)			
Type of Ex-Protection	Class I&II, Division 2	Permissible number of consecutive starts	Cold	2 times	
Applicable Standard	NEMA MG1, CSA C390	Hot	1 time		
		Paint	Munsell No.	4.0PB5.4/5.5(VL-451)	

ACCESSORIES
*. B.T.D.(Pt 100 Ω at 0°C,Single) : 2EA/Motor
*. W.T.D.(Pt 100 Ω at 0°C) : 2EA/Ph.
*. Space Heater : 1EA/Motor

SPARE PARTS
1. Spare Axial Fan (C.W Direction)

SUBMITTAL DRAWING		
Outline Dimension Drawing	Motor Weight(Approx.)	
B35	LM-T0509C4C7001	4000 lb.

REMARK
1. Premium efficiency according to NEMA MG1
2. Inverter Duty @ 1.0 Service Factor & F Temperature rise
-. 10:1 VT (20:1 VT at 50% load)
-. 10:1 CT
-. CHp up to 1.5 times base speed, NEMA MG1 Part31
3. NDE side : Insulated bearing
4. CSA Certification
-. Class I, Division 2, Group A, B, C & D; Temp code : T3
-. Class II, Division 2 Group F & G; Temp code : T3
5. Shaft material : AISI4140
6. Uni-directional CCW viewed from drive end.

Date	DSND	CHKD	CHKD	APPD
2024-09-10	S.H. Lee	I.K. Kim	R.G. Kim	S.W. Kim

[Note] Others not mentioned in this data sheet shall be in accordance with maker standard.
 Above technical data are only design values and shall be guaranteed with tolerance of applicable standard.
 Inspection and performance test shall be done according to maker standard, if not mentioned.
 * In case of Inverter-Fed Motor, performance data is based on sine wave tests. It may be different from test data of Inverter combined motor.
 ** Data is based on rated voltage & frequency and is expressed as a percentage of full-load value.

본 도면은 HD현대일렉트릭(주) 재산이며
허가없이 복사할 수 없음 (취급주의)

THIS DRAWING IS PROPRIETARY TO HYUNDAI ELECTRIC. NO PART OF THIS DRAWING
MAYBE REPRODUCED WITHOUT THE PERMISSION OF HYUNDAI ELECTRIC.

1	2	3	4
REV	DATE	CONTENTS	REVD BY

4.72

CROWN TRITON
Premium Efficiency AC 3 Phase Motor





450HP 2P 460V		Cat. No. HSDE450-36-5009SC-IBBRSRSHSP	
Model LATER	INS. Class F	Amps 487.7	
Type PJP	Duty CONT	Code G	Amb. 40°C
Frame 5009SC	Encl. TEFC	S.F. 1.15	RPM 3570
Bearing	Drive 6315C3	S.F.1.00 (10:1 C.T., 20:1 V.T., NEMA-MG1 Part31)	
	Opp. 6315C3-INS.	NEMA Nom. Eff. 95.8%	3/4 Eff. 94.8%
Usable at	50Hz 335HP 380V 445.49A 2970rpm S.F.: 1.15 Eff.: 95.8% Code: H		
	50Hz 335HP 400/415V 428.03/417.25A 2972/2975rpm S.F.: 1.15 Eff.: 95.8/95.81% Code: J/K		
CSA Certified for	CLASS I, Div. 2, Gr. A, B, C & D	CLASS II, Div. 2, Gr. F & G	Temp. Code (sine wave)
	CLASS I, Zone 2, Gr. IIA, IIB, & IIC		Frame L440FR - 500FR
No. -	Date -	Amb. 40°C T3 (200°C)	Amb. 55°C T3 (200°C)
4M-136053		Weight 4000 lb	
MARINE DUTY IEEE45		Made in Korea H1	

2.36

APPD BY	S.Y.KIM	UNIT	INCH	SUBJECT	CSA Class I, Division2 Severe Duty (HSDE ,L449-500)	DWG SIZE
CHKD BY	I.K.KIM	SCALE	NONE			A4 (1:1)
CHKD BY	R.G.KIM	PROJEC'N	3rd Angle	NAMEPLATE DRAWING		
DSND BY	S.H.LEE	DATE	2024.06.07			
				REF. NO	4M-136053	Sheet No. of
				DWG NO	NP-HSDE450-36-5009SC-IBBRSRSHSP	Revision No. 0



PERFORMANCE CURVE

CURVE NO.

PC-HSDE450-36-5009SC-IBBRSRSHSP

Type :	PJP
Full Load Torque :	661.1 lb.ft
Load moment of Inertia (J) :	349.000 lb.ft2
Motor moment of Inertia (J) :	70.485 lb.ft2

335kW	450HP	2 P	60 Hz
Speed at Full Load :			3570 RPM
Rated Voltage	575V	460V	230V
Full Load Current	390.1A	487.7A	975.3A

SPEED VS TORQUE & CURRENT CURVE

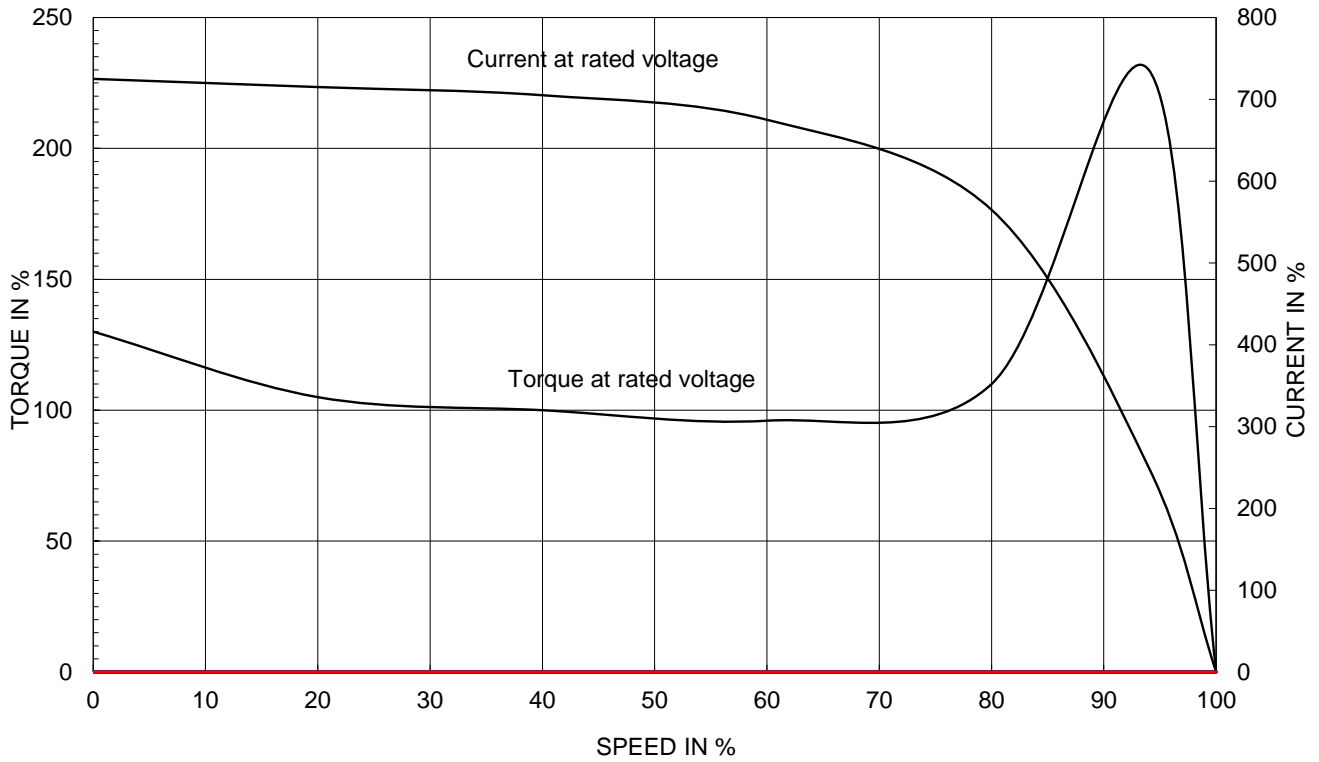

OUTPUT VS EFF., P.F & CURRENT CURVE

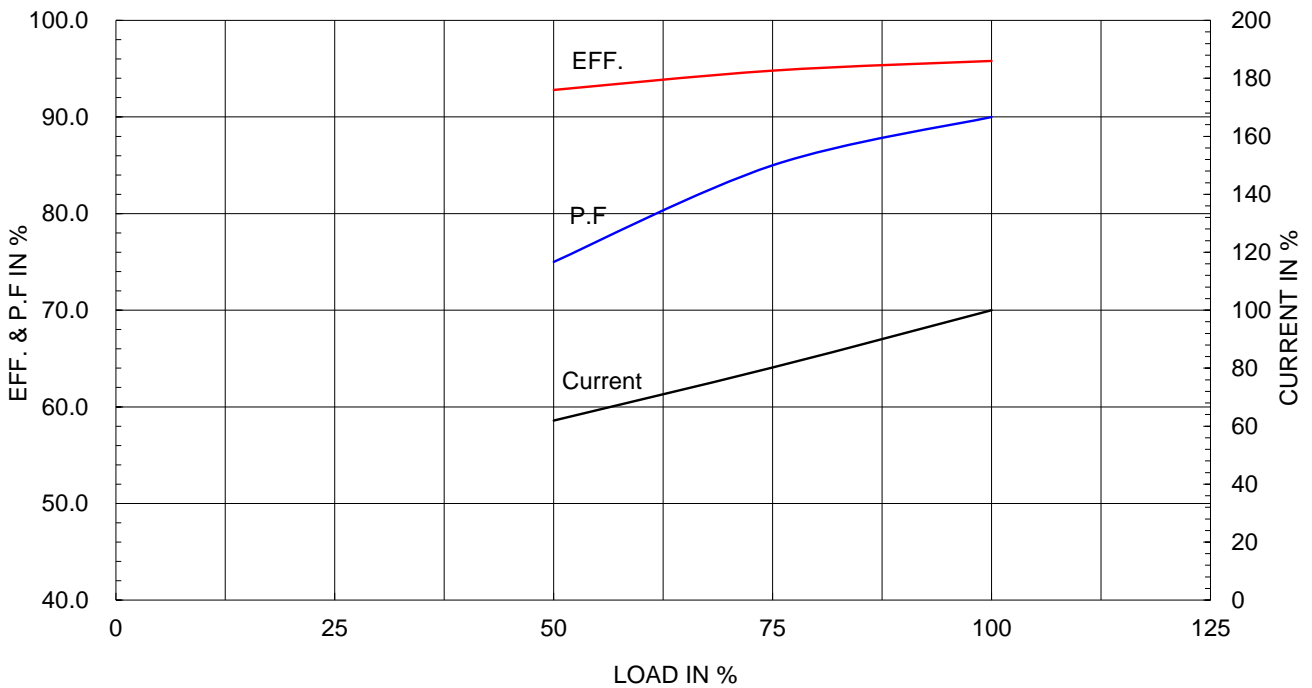

본 도면은 HD현대일렉트릭(주) 재산이며 허가없이 복사할 수 없음 (취급주의)

THIS DRAWING IS PROPRIETARY TO HYUNDAI ELECTRIC. NO PART OF THIS DRAWING MAYBE REPRODUCED WITHOUT THE PERMISSION OF HYUNDAI ELECTRIC.

▽	50S	REV	DATE	CONTENTS	REVD BY	CHKD BY	CHKD BY	APPD BY
▽▽	12.5S							
▽▽▽	3.2S							
▽▽▽▽	0.4S							

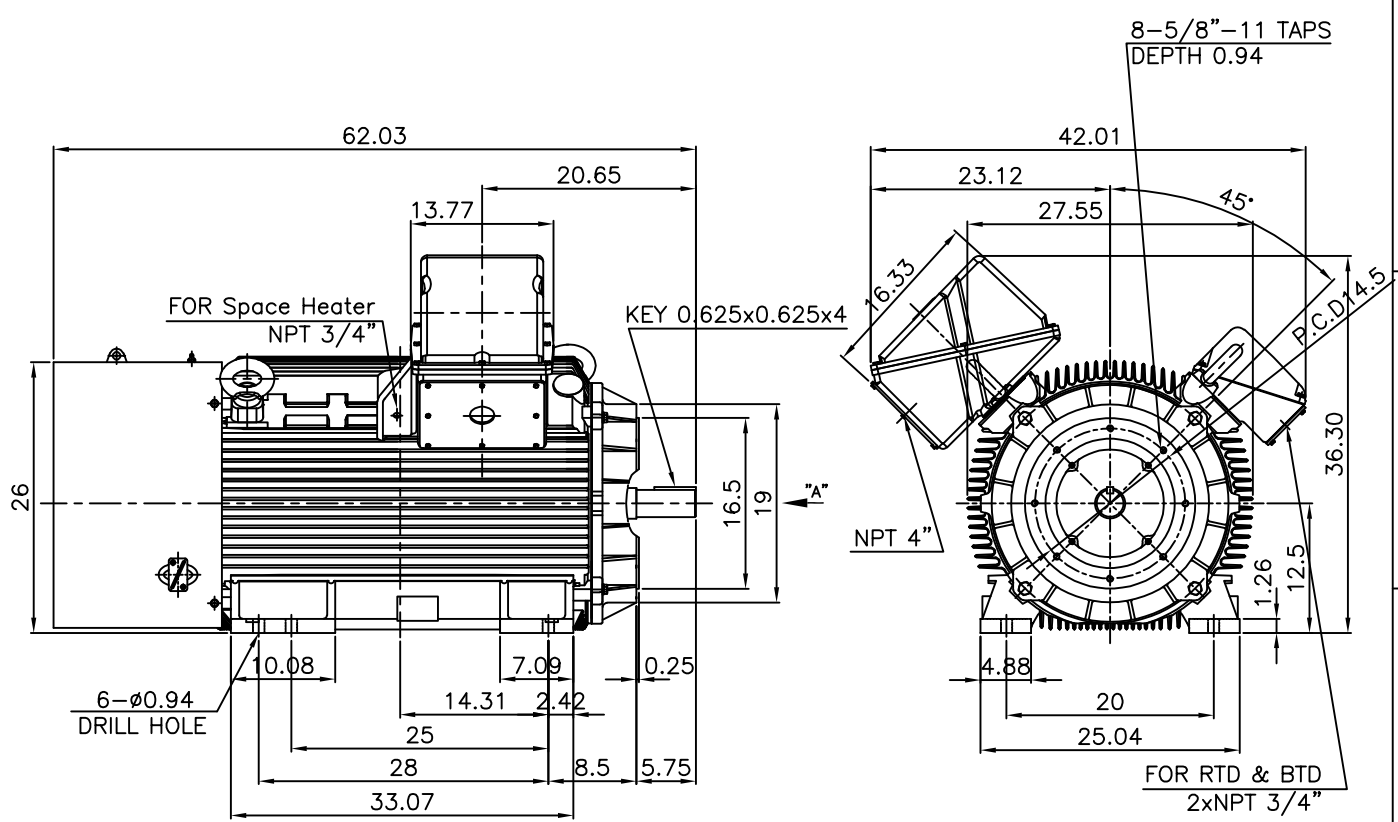

NOTE

1.TOLERANCE :

CENTER HEIGHT	12.5	+0.000	-0.060
RABBET DIAMETER	∅16.5	+0.000	-0.005
SHAFT DIAMETER	∅2.625	+0.000	-0.001
KEYWAY WIDTH	0.625	+0.002	-0.000

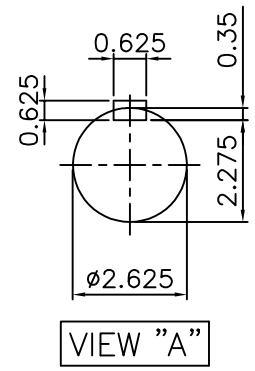

APPD BY	S.Y.KIM	UNIT	INCH	SUBJECT	Fr.5008/5009SC	DWG SIZE	A4 (1:19)
CHKD BY	O.J.KIM	SCALE	1/19	TITLE	OUTLINE	REF. NO	Sheet No. of
CHKD BY	R.G.KIM	PROJEC'N	3각법(3rd Angle)				
DSND BY	H.K.LEE	DATE	2021-04-27				
				DWG NO	LM-T0509C4C7001	Revision No. 0	

**Cls. I&II, Div. 2
IEEE 841**

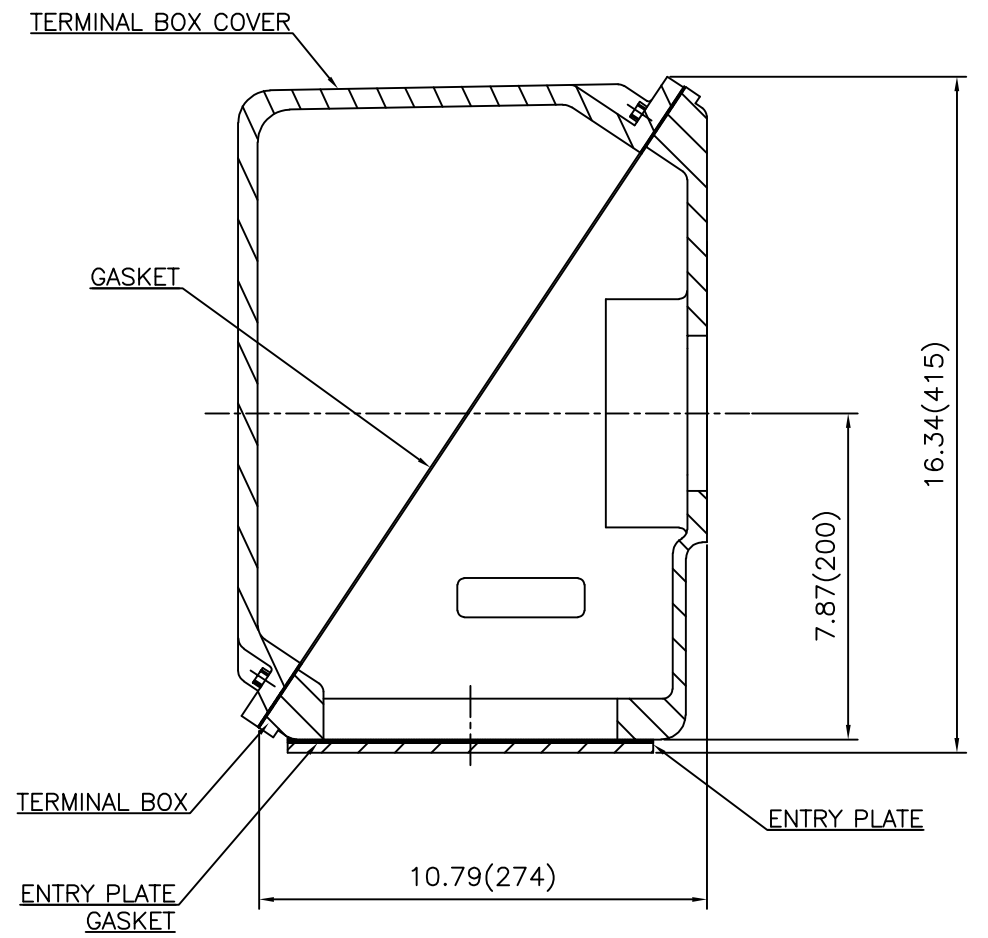
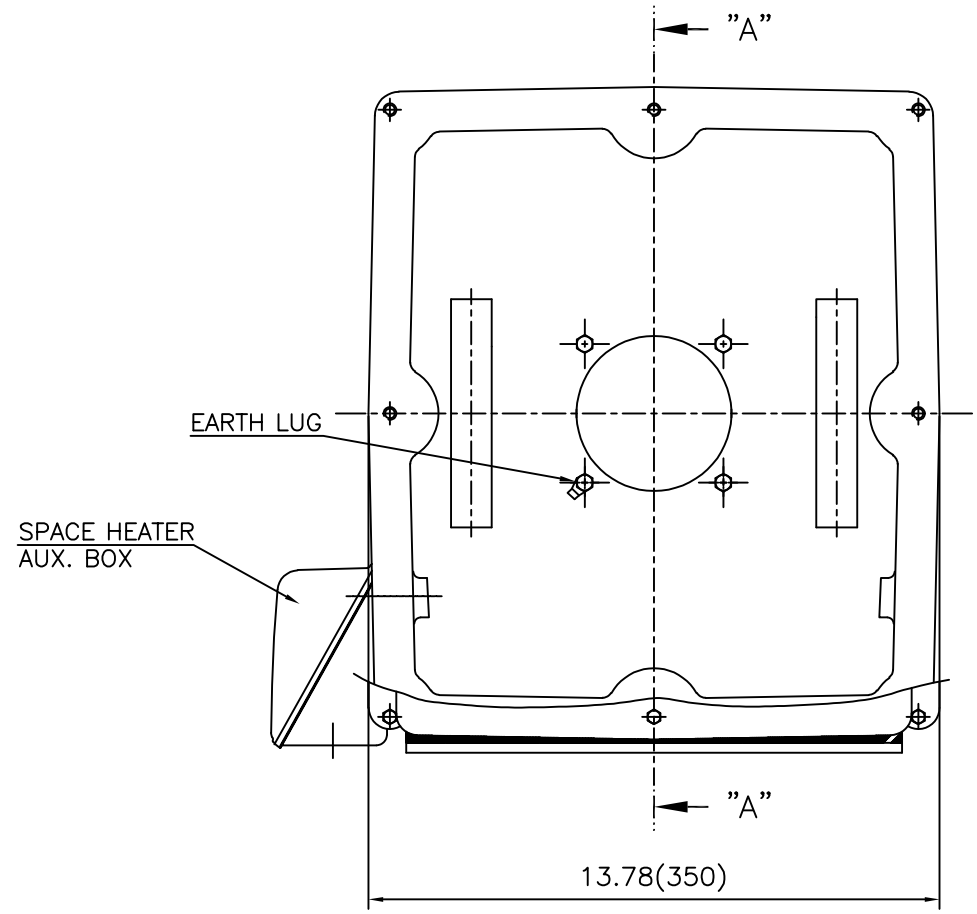

SEC. "A" - "A"

REV	DATE	CONTENTS	REVD BY	CHKD BY	CHKD BY	APPD BY

APPD BY	S.Y.KIM	UNIT	inch(mm)	SUBJECT	FR. L440 (CAST IRON)	DWG SIZE
CHKD BY		SCALE	1/3.5	TITLE	MAIN TERMINAL BOX ASS'Y	A3 (1:3.5)
CHKD BY	R.G.KIM	PROJEC'N	3rd Angle			
DSND BY	최승희	DATE	2023-10-19	REF. NO		Sheet No. of
				DWG NO	3M-248452	Revision No. 0

**Cls. I&II, Div. 2
IEEE 841**

본 도면은 HD현대일렉트릭(주) 재산이며
허가없이 복사할 수 없음 (취급주의)

THIS DRAWING IS PROPRIETARY TO HYUNDAI ELECTRIC. NO PART OF THIS DRAWING
MAY BE REPRODUCED WITHOUT THE PERMISSION OF HYUNDAI ELECTRIC.



REV	DATE	CONTENTS	REVD BY	CHKD BY	CHKD BY	APPD BY

APPD BY	S.Y.KIM	UNIT	inch(mm)	SUBJECT	FR.360 (CAST IRON)	DWG SIZE	A3 (1:2.2)
CHKD BY		SCALE	1/1	TITLE	AUX. TERMINAL BOX ASS'Y	REF. NO	
CHKD BY	R.G.KIM	PROJEC'N	3rd Angle	DWG NO		3M-165277	Sheet No.
DSND BY	박승희	DATE	2024-01-18			DWG NO	3M-165277

**Cls. I&II, Div. 2
IEEE 841**

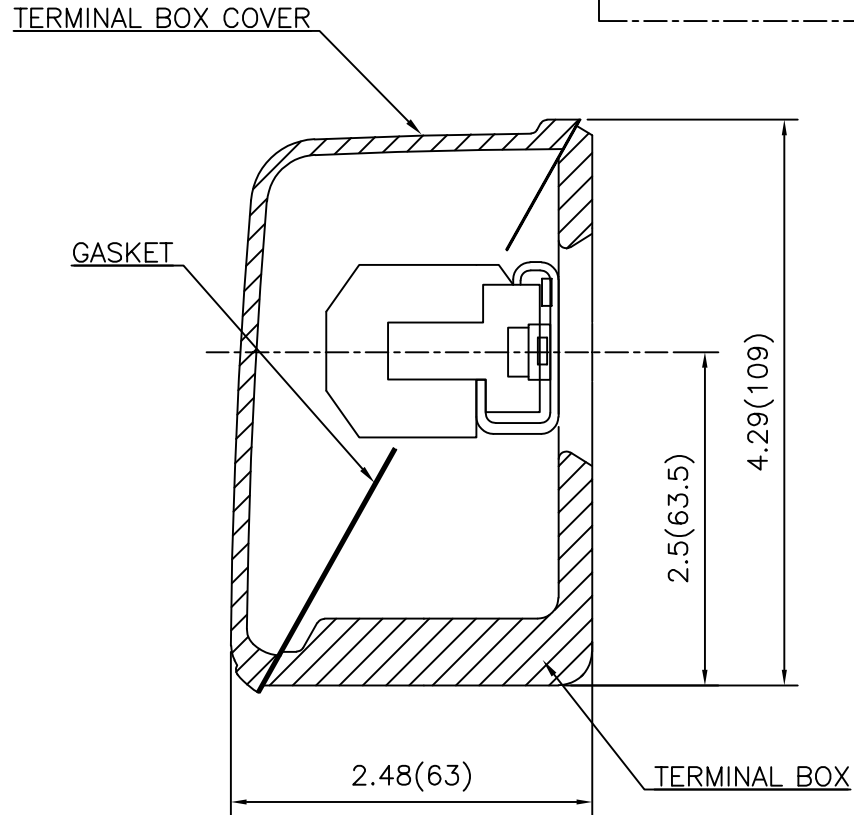

SEC. "A" - "A"

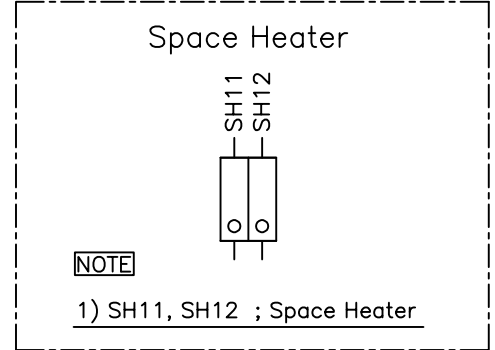

REV	DATE	CONTENTS	REVD BY	CHKD BY	CHKD BY	APPD BY

APPD BY	S.Y.KIM	UNIT	inch(mm)	SUBJECT	FR.180 (CAST IRON)	DWG SIZE
CHKD BY		SCALE	1/1	TITLE	SUB. TERMINAL BOX ASS'Y	A3 (1:1.1)
CHKD BY	R.G.KIM	PROJEC'N	3rd Angle			
DSND BY	배승희	DATE	2024-01-18			
				REF. NO		Sheet No. of
				DWG NO	3M-165277	Revision No. 0