

Customer :
 Project Name :
 Project No. :
 Revision No. :

SPECIFICATION for INDUCTION MOTOR



0		For Bidding			
No.	DATE	DESCRIPTION	PREPARED BY	CHECKED BY	APPROVED BY



AC INDUCTION MOTOR DATA SHEET

IEEE841 TYPE

Catalog No.	IEEE300-18-L449TC-IBSH	Item No.	Rev. No. []
Project Name		Project No.	Quantity sets

GENERAL SPECIFICATION		PERFORMANCE DATA			
Frame Size	L449TC	Rated Output	225 kW 300 HP		
Type	PJP	Number of Poles	4		
Enclosure(Protection)	Totally Enclosed / IP55	Rotor Type	Squirrel Cage		
Method of Cooling	IC411(FC)	Starting Method*	D.O.L		
Rated Frequency	60 Hz	Rated Voltage	575 V	460 V	230 V
Number of Phases	3	Current	Full Load	266.9 A	333.6 A
Insulation Class	F		Locked-rotor**	710 %	710 %
Temp. Rise at full load (by resistance method)		Efficiency			
at 1.0 S.F	80 deg. C	50% Load		93.2 %	
Motor Location	<input type="checkbox"/> Indoor <input type="checkbox"/> Outdoor	75% Load		95.2 %	
Altitude	Less than 1,000 meter	100% Load		96.2 %	
Relative Humidity	Less than 80 %	Power Factor(p.u)			
Ambient Temp.	40 deg. C (Max.)	50% Load		0.730	
Duty Type	Continuous (S1)	75% Load		0.830	
Service Factor	1.15	100% Load		0.880	
Mounting	B35	Speed at Full Load	1785 r.p.m		
Bearing	Type	Anti-Friction	Torque		
	DE/N-DE	6322C3 / 6318C3-INS.	Full Load	888.0 lb.ft	
	Lubricant	Grease(Polyrex-EM)	Locked-rotor**	135 %	
External Thrust	Not applicable	Breakdown**	225 %		
Coupling Method	<input checked="" type="checkbox"/> Direct <input type="checkbox"/> V-belt	Moment of Inertia (J)			
Shaft Extension	Single	Load(Max.)	1,200.000 lb.ft2		
Terminal Box	Main	Cast Iron	Motor	101.100 lb.ft2	
	Aux.	Yes	Sound Pressure Level (No-load & mean value at 1m from motor)		
Location	Refer to Outline Drawing	85 dB(A)			
Application		Vibration			
Area classification	Hazardous	3.8 mm/sec (peak)			
Type of Ex-Protection	Class I&II, Division 2	Permissible number of consecutive starts	Cold	2 times	
Applicable Standard	IEEE841, NEMA MG1, CSA C390	Hot	1 time		
		Paint	Munsell No.	7.5BG6/1.5	

ACCESSORIES
*. Space Heater : 1EA/Motor

SUBMITTAL DRAWING		
Outline Dimension Drawing	Motor Weight(Approx.)	
B35	LM-I044XC4UE001	2990 lb.

SPARE PARTS

REMARK				
1. Premium efficiency according to NEMA MG1				
2. Inverter Duty @ 1.0 Service Factor & F Temperature rise				
-. 10:1 VT (20:1 VT at 50% load)				
-. 10:1 CT				
-. CHp up to 1.5 times base speed, NEMA MG1 Part31				
3. NDE side : Insulated bearing				
4. CSA Certification				
-. Class I, Division 2, Group A, B, C & D; Temp code : T3				
-. Class II, Division 2 Group F & G; Temp code : T3				
5. Shaft material : AISI4140				
Date	DSND	CHKD	CHKD	APPD
2024-09-22	E.J.LEE	I.K. Kim	R.G. Kim	S.W. Kim

[Note] Others not mentioned in this data sheet shall be in accordance with maker standard.
 Above technical data are only design values and shall be guaranteed with tolerance of applicable standard.
 Inspection and performance test shall be done according to maker standard, if not mentioned.
 * In case of Inverter-Fed Motor, performance data is based on sine wave tests. It may be different from test data of Inverter combined motor.
 ** Data is based on rated voltage & frequency and is expressed as a percentage of full-load value.

1	2	3	4
REV	DATE	CONTENTS	REVD BY CHKD BY CHKD BY APPD BY

4.72



CROWN TRITON
Premium Efficiency AC 3 Phase Motor

300HP 4P 460V Cat. No. IEE300-18-L449TC-IBSH

Model	LATER	INS. Class	F	Amps	333.6
Type	PJP	Duty	CONT	Code	G
Frame	L449TC	Encl.	TEFC	Amb.	40°C
Bearing	Drive	6322C3	S.F. 1.15	RPM	1785
	Opp.	6318C3-INS.	S.F.1.00 (10:1 C.T., 20:1 V.T., NEMA-MG1 Part31)		NEMA Nom. Eff.
Usable at	50Hz 250HP 380V 341.71A 1485rpm S.F.: 1.0 Eff.: 96% Code: H		3/4 Eff. 95.2%		
	50Hz 250HP 400/415V 332.17/327.45A 1486/1487rpm S.F.: 1.0 Eff.: 96/96.1% Code: J/J		NEMA Design B Torque		
CSA Certified for	CLASS I, Div. 2, Gr. A, B, C & D		CLASS II, Div. 2, Gr. F & G		Temp. Code
	CLASS I, Zone 2, Gr. IIA, IIB, & IIC				(sine wave)
					Frame L440FR - 500FR
No.	-	Date	-	Weight	2990 lb

IEEE Std 841-2021 MARINE DUTY IEE45
4M-136054 Made in Korea H1

2.36

APPD BY	S.Y.KIM	UNIT	INCH	SUBJECT	CSA Class I, Division2 IEE841 (XL)	DWG SIZE
CHKD BY	I.K.KIM	SCALE	NONE			A4 (1:1)
CHKD BY	R.G.KIM	PROJEC'N	3rd Angle	NAMEPLATE DRAWING		
DSND BY	S.H.LEE	DATE	2024.06.07			
				REF. NO	4M-136054	Sheet No. of
				DWG NO	NP-IEE300-18-L449TC-IBSH	Revision No. 0

Type :	PJP
Full Load Torque :	888.0 lb.ft
Load moment of Inertia (J) :	1200.000 lb.ft2
Motor moment of Inertia (J) :	101.100 lb.ft2

225kW 300HP	4 P	60 Hz
Speed at Full Load :		1785 RPM
Rated Voltage	575V	460V 230V
Full Load Current	266.9A	333.6A 667.2A

SPEED VS TORQUE & CURRENT CURVE

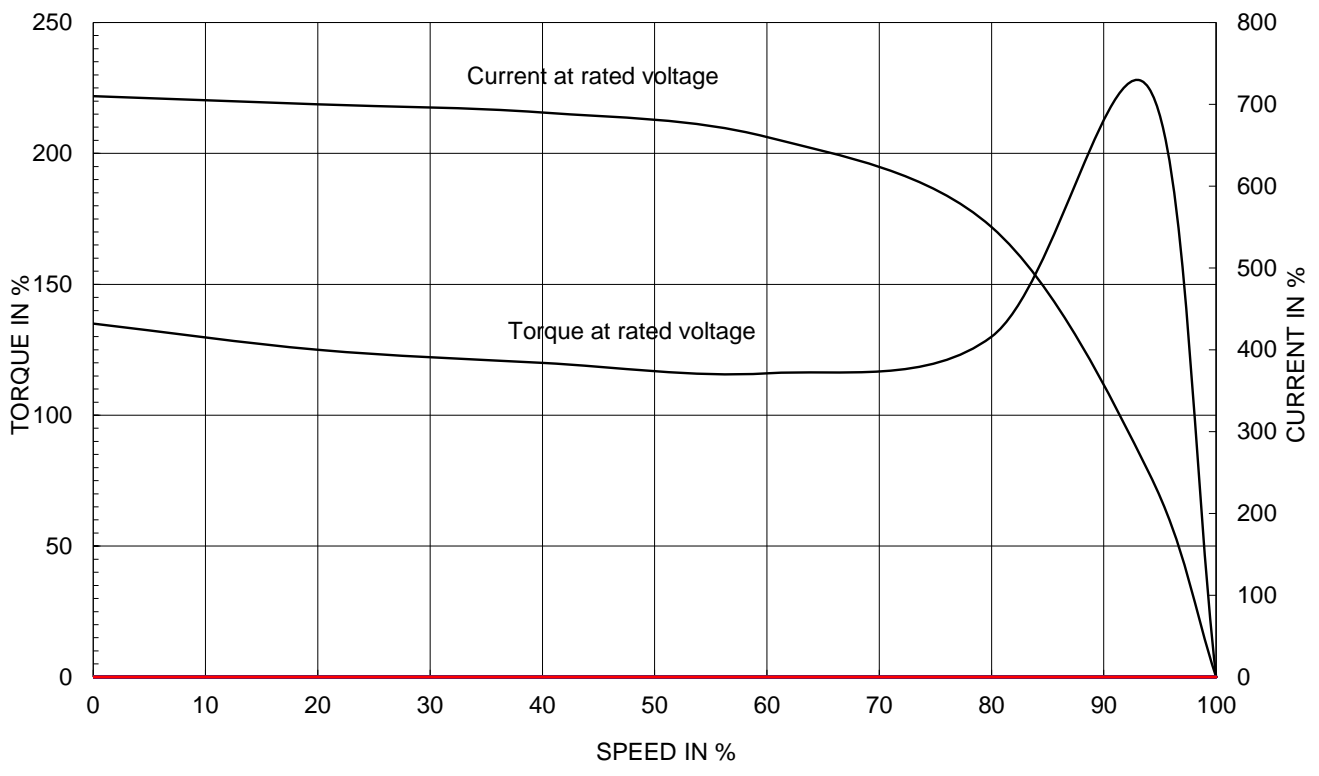

OUTPUT VS EFF., P.F & CURRENT CURVE

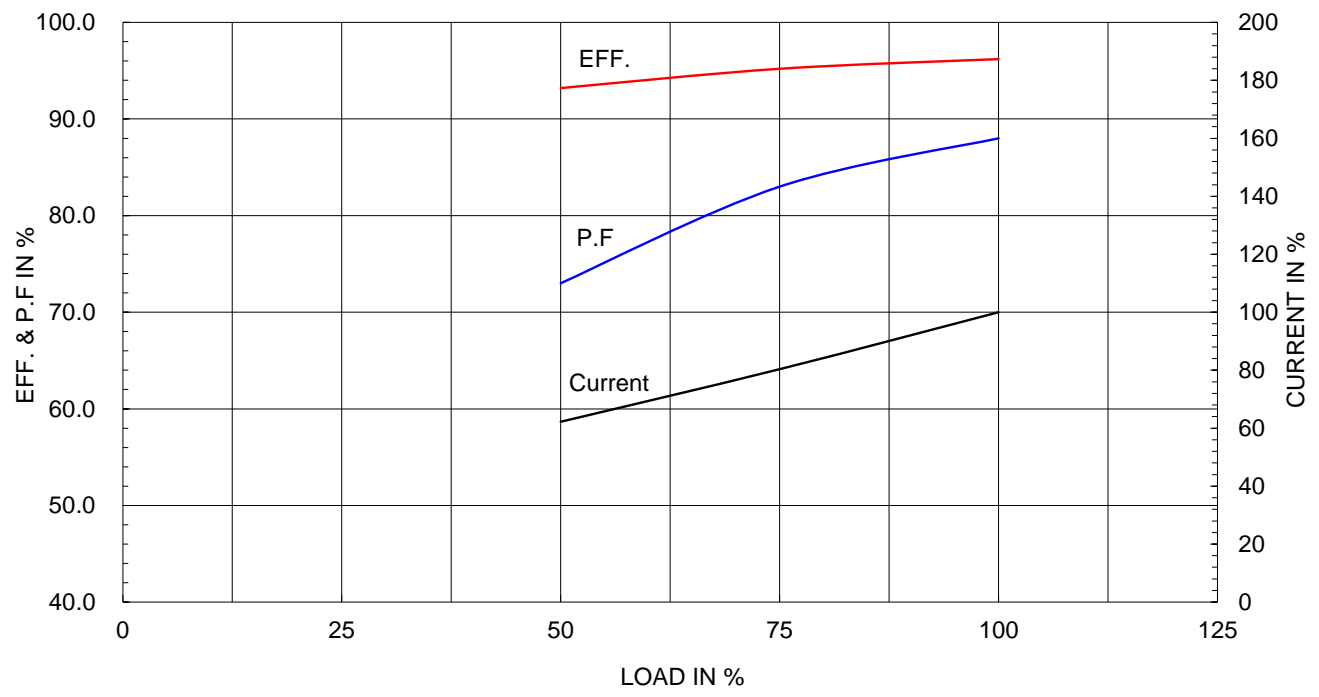

▽	50S	REV	DATE	CONTENTS	REVD BY	CHKD BY	CHKD BY	APPD BY
▽▽	12.5S							
▽▽▽	3.2S							
▽▽▽▽	0.4S							

IEEE841

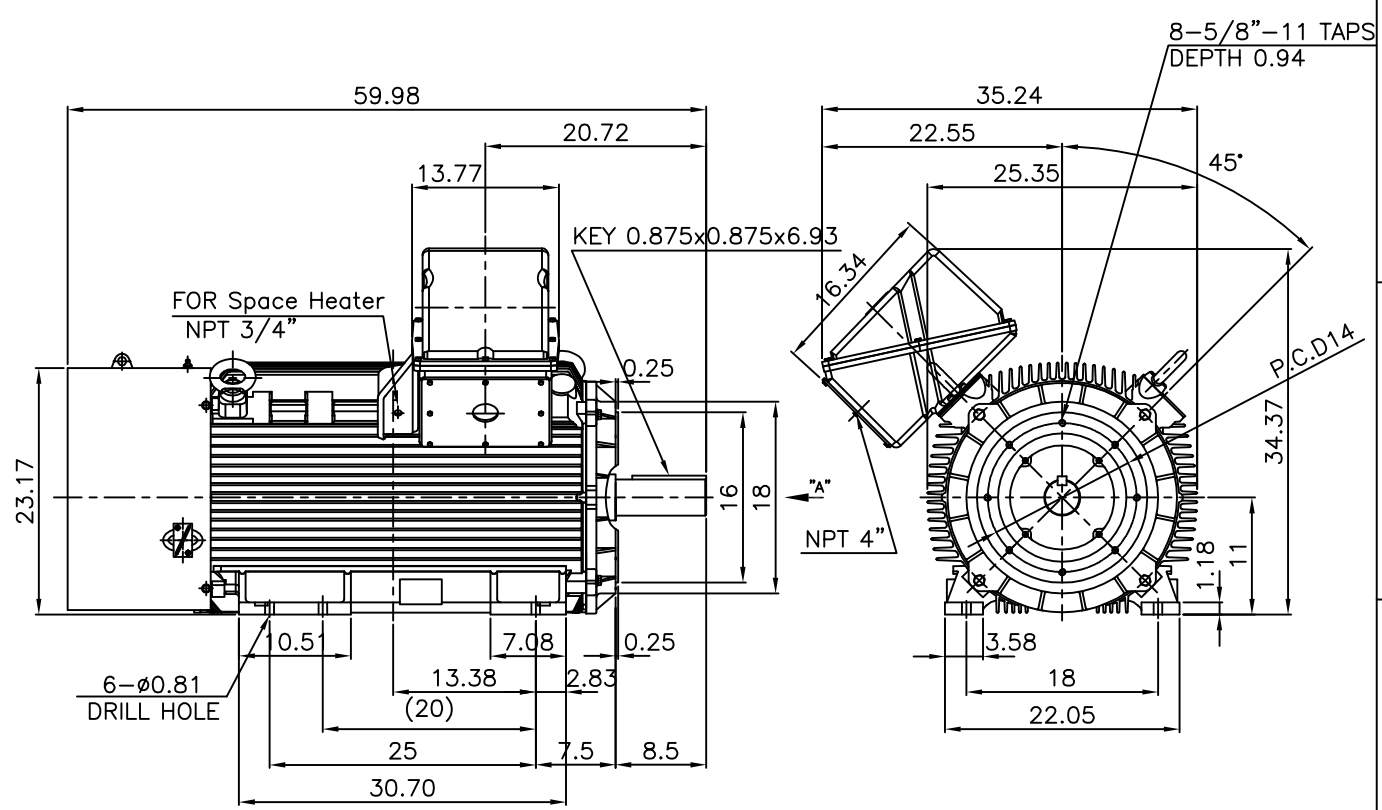

NOTE

1.TOLERANCE :

CENTER HEIGHT	11	+0.000	-0.060
RABBET DIAMETER	ø16	0	-0.005
SHAFT DIAMETER	ø3.375	+0.000	-0.001
KEYWAY WIDTH	0.875	+0.003	-0.000

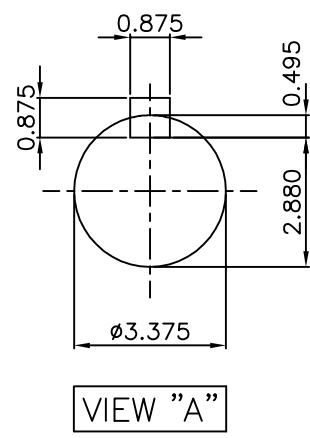

VIEW "A"

APPD BY	S.Y.KIM	UNIT	INCH	SUBJECT	Fr.L449TC	DWG SIZE	A4 (1:18)
CHKD BY	O.J.KIM	SCALE	1/18	TITLE	OUTLINE		
CHKD BY	R.G.KIM	PROJEC'N	3각법(3rd Angle)	REF. NO		Sheet No.	of
DSND BY	H.K.LEE	DATE	2021-04-27	DWG NO	LM-1044XC4UE001	Revision No.	0

**Cls. I&II, Div. 2
IEEE 841**

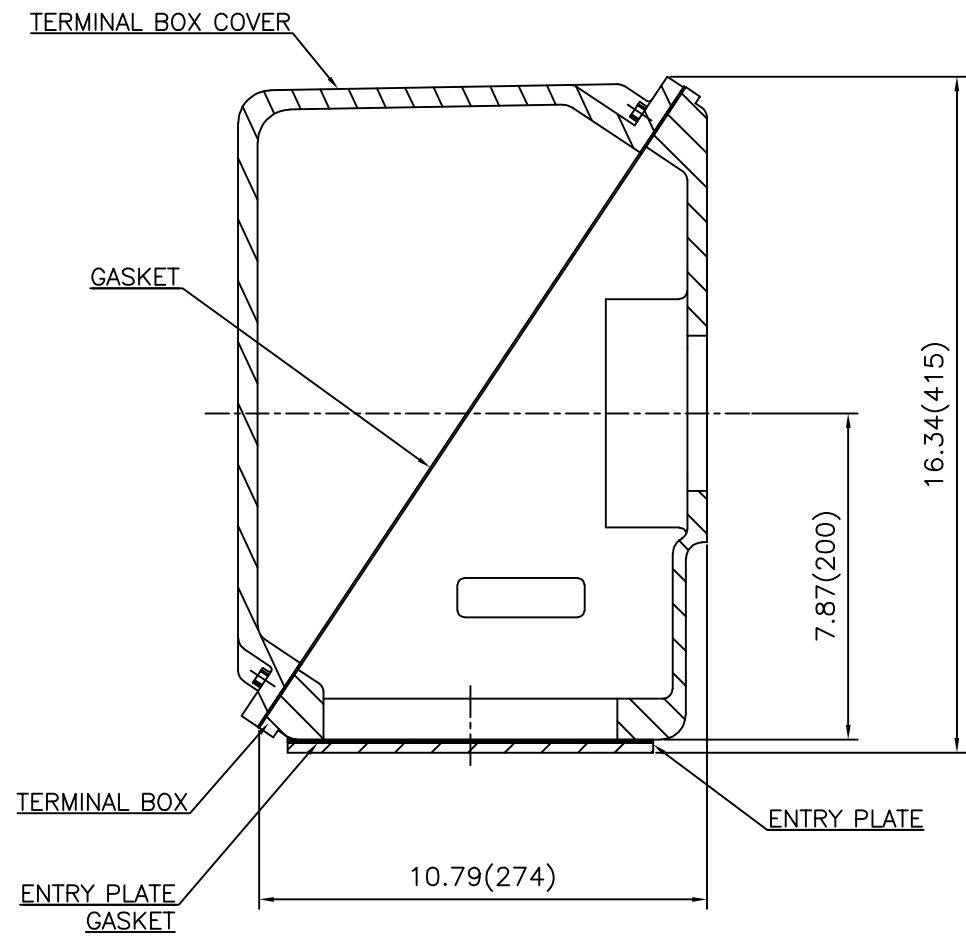
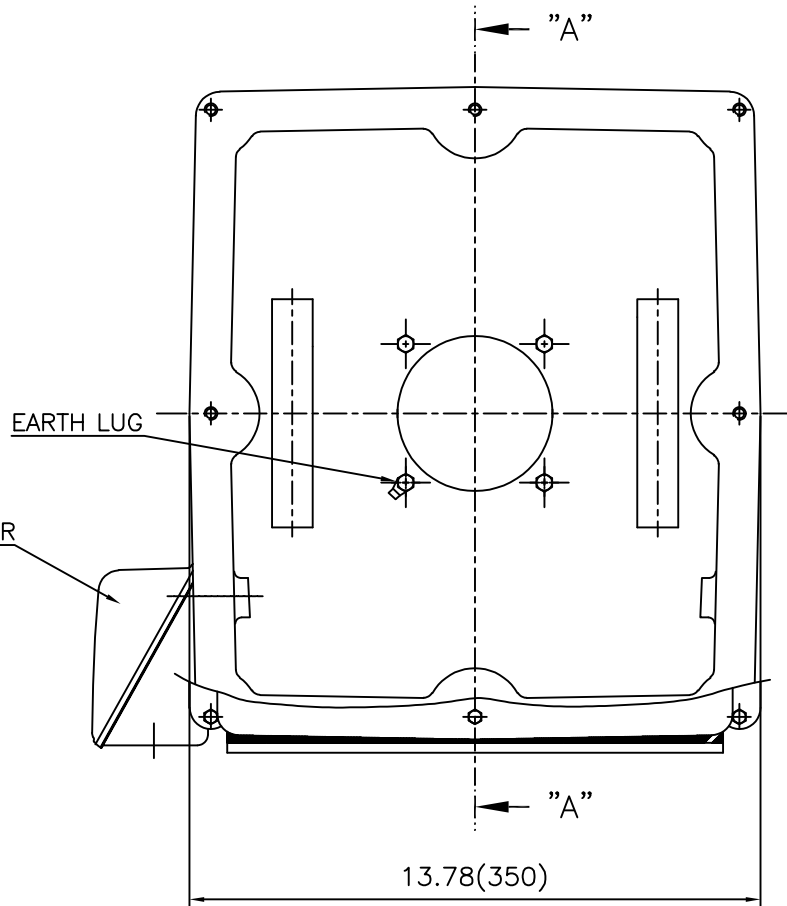

SEC. "A" - "A"

REV	DATE	CONTENTS	REVD BY	CHKD BY	CHKD BY	APPD BY

APPD BY	S.Y.KIM	UNIT	inch(mm)	SUBJECT	FR. L440 (CAST IRON)	DWG SIZE
CHKD BY		SCALE	1/3.5	TITLE	MAIN TERMINAL BOX ASS'Y	A3 (1:3.5)
CHKD BY	R.G.KIM	PROJEC'N	3rd Angle			
DSND BY	최승희	DATE	2023-10-19			
				REF. NO		Sheet No. of
				DWG NO	3M-248452	Revision No. 0

**Cls. I&II, Div. 2
IEEE 841**



REV	DATE	CONTENTS	REVD BY	CHKD BY	CHKD BY	APPD BY

APPD BY	S.Y.KIM	UNIT	inch(mm)	SUBJECT	FR.180 (CAST IRON)	DWG SIZE	A3 (1:1.1)
CHKD BY		SCALE	1/1	TITLE	SUB. TERMINAL BOX ASS'Y		
CHKD BY	R.G.KIM	PROJEC'N	3rd Angle	REF. NO		Sheet No.	of
DSND BY	배승희	DATE	2024-01-18	DWG NO	3M-165278	Revision No.	0

