

Customer :
 Project Name :
 Project No. :
 Revision No. :

SPECIFICATION for INDUCTION MOTOR



0		For Bidding			
No.	DATE	DESCRIPTION	PREPARED BY	CHECKED BY	APPROVED BY



AC INDUCTION MOTOR DATA SHEET

Catalog No.	HSDE250-12-L449T-IBBRSRSH	Item No.		Rev. No.	[]
Project Name		Project No.		Quantity	sets

GENERAL SPECIFICATION			PERFORMANCE DATA			
Frame Size	L449T		Rated Output	190 kW 250 HP		
Type	PJP		Number of Poles	6		
Enclosure(Protection)	Totally Enclosed	/ IP55	Rotor Type	Squirrel Cage		
Method of Cooling	IC411(FC)		Starting Method*	D.O.L		
Rated Frequency	60 Hz		Rated Voltage	575 V	460 V	230 V
Number of Phases	3		Current	Full Load	237.1 A	296.3 A
Insulation Class	F			Locked-rotor**	680 %	680 %
Temp. Rise at full load (by resistance method)			Efficiency			
at 1.0 S.F			80 deg. C			
Motor Location	<input type="checkbox"/> Indoor <input type="checkbox"/> Outdoor		50% Load		92.8 %	
Altitude	Less than 1,000 meter		75% Load		94.8 %	
Relative Humidity	Less than 80 %		100% Load		95.8 %	
Ambient Temp.	40 deg. C (Max.)		Power Factor(p.u)			
Duty Type	Continuous (S1)		50% Load		0.690	
Service Factor	1.15		75% Load		0.790	
Mounting	B3		100% Load		0.840	
Bearing	Type	Anti-Friction	Speed at Full Load			
	DE/N-DE	NU322 / 6318C3-INS.	1185 r.p.m			
	Lubricant	Grease(Polyrex-EM)	Torque			
External Thrust	Not applicable		Full Load		1,129.6 lb.ft	
Coupling Method	<input type="checkbox"/> Direct <input type="checkbox"/> V-belt		Locked-rotor**		135 %	
Shaft Extension	Single		Breakdown**		200 %	
Terminal Box	Main	Cast Iron	Moment of Inertia (J)			
	Aux.	Yes	Load(Max.)		2,740.000 lb.ft2	
Location	Refer to Outline Drawing		Motor		158.295 lb.ft2	
			Sound Pressure Level (No-load & mean value at 1m from motor)			
Application			80 dB(A)			
Area classification	Hazardous		Vibration			
Type of Ex-Protection	Class I&II, Division 2		3.8 mm/sec (peak)			
Applicable Standard	NEMA MG1, CSA C390		Permissible number of consecutive starts		Cold 2 times	
ACCESSORIES *. B.T.D.(Pt 100 Ω at 0°C,Single) : 2EA/Motor *. W.T.D.(Pt 100 Ω at 0°C) : 2EA/Ph. *. Space Heater : 1EA/Motor			Hot		1 time	
			Paint	Munsell No.	4.0PB5.4/5.5(VL-451)	

ACCESSORIES	SUBMITTAL DRAWING		
*. B.T.D.(Pt 100 Ω at 0°C,Single) : 2EA/Motor *. W.T.D.(Pt 100 Ω at 0°C) : 2EA/Ph. *. Space Heater : 1EA/Motor	Outline Dimension Drawing \ Motor Weight(Approx.)		
	B3	LM-T044XB3U7001	2890 lb.

REMARK				
1. Premium efficiency according to NEMA MG1 2. Inverter Duty @ 1.0 Service Factor & F Temperature rise -. 10:1 VT (20:1 VT at 50% load) -. 10:1 CT -. CHp up to 1.5 times base speed, NEMA MG1 Part31 3. NDE side : Insulated bearing 4. CSA Certification -. Class I, Division 2, Group A, B, C & D; Temp code : T3 -. Class II, Division 2 Group F & G; Temp code : T3 5. Shaft material : AISI4140				
Date	DSND	CHKD	CHKD	APPD
2024-09-10	S.H. Lee	I.K. Kim	R.G. Kim	S.W. Kim

[Note] Others not mentioned in this data sheet shall be in accordance with maker standard.
 Above technical data are only design values and shall be guaranteed with tolerance of applicable standard.
 Inspection and performance test shall be done according to maker standard, if not mentioned.
 * In case of Inverter-Fed Motor, performance data is based on sine wave tests. It may be different from test data of Inverter combined motor.
 ** Data is based on rated voltage & frequency and is expressed as a percentage of full-load value.

1	2	3	4
REV	DATE	CONTENTS	REVD BY

4.72

CROWN TRITON
Premium Efficiency AC 3 Phase Motor







250HP	6P	460V	Cat. No.	HSDE250-12-L449T-IBBRSRSH			
Model	LATER		INS. Class	F	Amps	296.3	
Type	PJP	Duty	Code	H	Amb.	40°C	
Frame	L449T	Encl.	S.F.	1.15	RPM	1185	
Bearing	Drive	NU322	S.F.1.00 (10:1 C.T., 20:1 V.T., NEMA-MG1 Part31)		NEMA Nom. Eff.	95.8%	
	Opp.	6318C3-INS.			NEMA Design	B Torque	
Usable at	50Hz 200HP 380V 283.8A 985rpm S.F.: 1.0 Eff.: 95.6% Code: H						
	50Hz 200HP 400/415V 283.09/287.22A 986/987rpm S.F.: 1.0 Eff.: 95.6/95.6% Code: J/J						
CSA Certified for	CLASS I, Div. 2, Gr. A, B, C & D		CLASS II, Div. 2, Gr. F & G		Temp. Code (sine wave)	Frame	L440FR - 500FR
	CLASS I, Zone 2, Gr. IIA, IIB, & IIC					Amb. 40°C	T3 (200°C)
						Amb. 55°C	T3 (200°C)
No.	-		Date	-		Weight	2890 lb

4M-136053
Made in Korea H1



2.36

APPD BY	S.Y.KIM	UNIT	INCH	SUBJECT	CSA Class I, Division2 Severe Duty (HSDE ,L449-500)	DWG SIZE
CHKD BY	I.K.KIM	SCALE	NONE			A4 (1:1)
CHKD BY	R.G.KIM	PROJEC'N	3rd Angle	NAMEPLATE DRAWING		
DSND BY	S.H.LEE	DATE	2024.06.07			
				REF. NO	4M-136053	Sheet No. of
				DWG NO	NP-HSDE250-12-L449T-IBBRSRSH	Revision No.

Type :	PJP
Full Load Torque :	1129.6 lb.ft
Load moment of Inertia (J) :	2740.000 lb.ft ²
Motor moment of Inertia (J) :	158.295 lb.ft ²

190kW 250HP	6 P	60 Hz
Speed at Full Load :		1185 RPM
Rated Voltage	575V	460V 230V
Full Load Current	237.1A	296.3A 592.7A

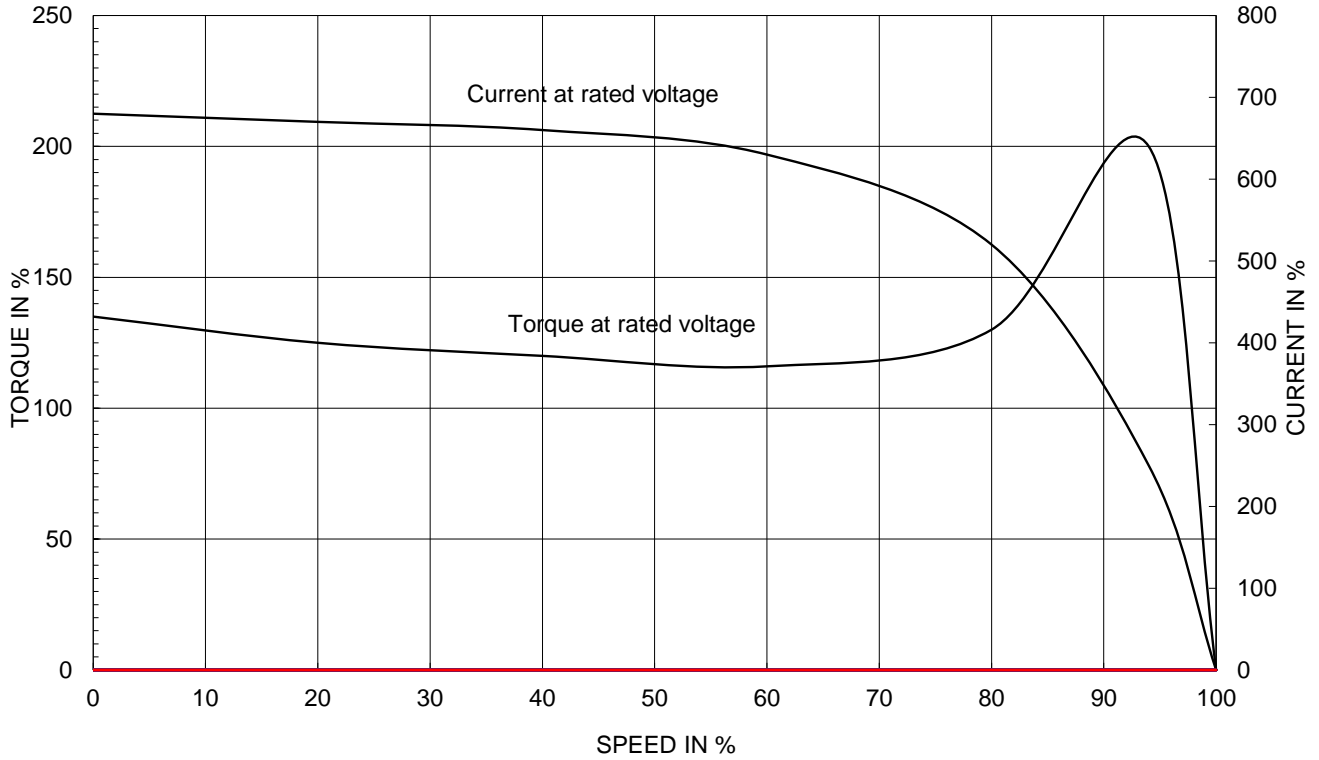
SPEED VS TORQUE & CURRENT CURVE



OUTPUT VS EFF., P.F & CURRENT CURVE

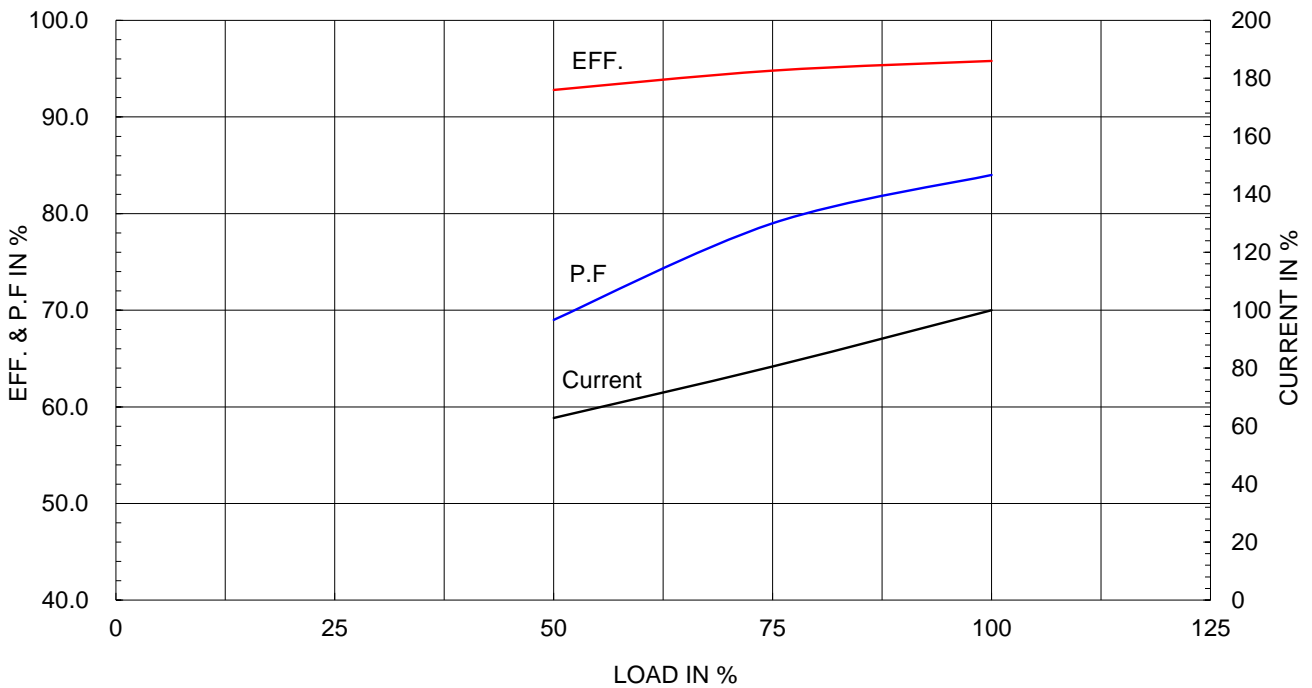

본 도면은 HD현대일렉트릭(주) 재산이며 허가없이 복사할 수 없음 (취급주의)

THIS DRAWING IS PROPRIETARY TO HYUNDAI ELECTRIC. NO PART OF THIS DRAWING MAYBE REPRODUCED WITHOUT THE PERMISSION OF HYUNDAI ELECTRIC.

▽	50S	REV	DATE	CONTENTS	REVD BY	CHKD BY	CHKD BY	APPD BY
▽▽	12.5S							
▽▽▽	3.2S							
▽▽▽▽	0.4S							

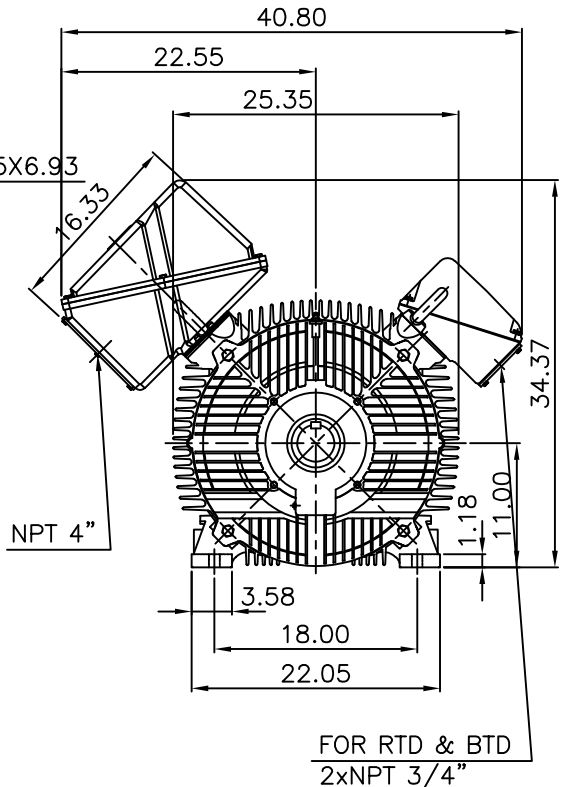
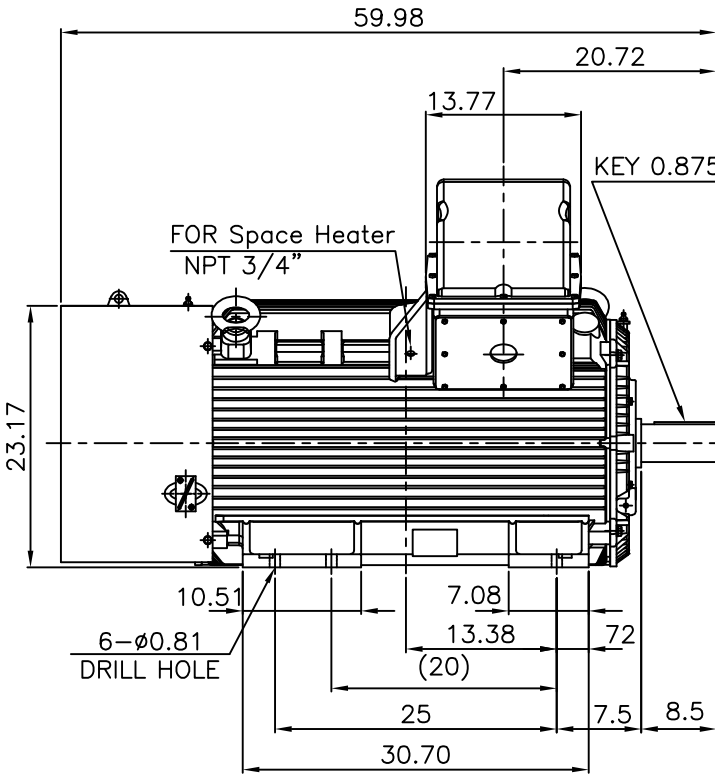

NOTE

1.TOLERANCE :

CENTER HEIGHT	11	+0.000	-0.060
SHAFT DIAMETER	ø3.375	+0.000	-0.001
KEYWAY WIDTH	0.875	+0.003	-0.000

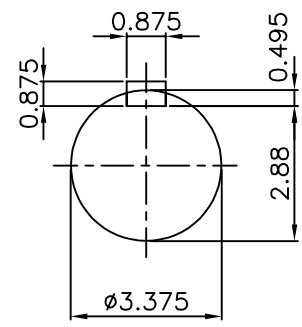

VIEW "A"

APPD BY	S.Y.KIM	UNIT	INCH	SUBJECT	Fr.L449T	DWG SIZE	A4 (1:18)
CHKD BY	O.J.KIM	SCALE	1/18	TITLE	OUTLINE	REF. NO	Sheet No. of
CHKD BY	R.G.KIM	PROJEC'N	3각법(3rd Angle)				
DSND BY	H.K.LEE	DATE	2021-04-27				
				DWG NO	LM-T044XB3U7001	Revision No. 0	

**Cls. I&II, Div. 2
IEEE 841**



SEC. "A" - "A"

REV	DATE	CONTENTS	REVD BY	CHKD BY	CHKD BY	APPD BY
1						
2						
3						
4						

APPD BY	S.Y.KIM	UNIT	inch(mm)	SUBJECT	FR. L440 (CAST IRON)	DWG SIZE
CHKD BY		SCALE	1/3.5	TITLE	MAIN TERMINAL BOX ASS'Y	A3 (1:3.5)
CHKD BY	R.G.KIM	PROJEC'N	3rd Angle			
DSND BY	최승희	DATE	2023-10-19			
				REF. NO		Sheet No. of
				DWG NO	3M-248452	Revision No. 0

Cls. I&II, Div. 2 IEEE 841

본 도면은 HD현대일렉트릭(주) 재산이며
허가없이 복사할 수 없음 (취급주의)

THIS DRAWING IS PROPRIETARY TO HYUNDAI ELECTRIC. NO PART OF THIS DRAWING
MAY BE REPRODUCED WITHOUT THE PERMISSION OF HYUNDAI ELECTRIC.



REV	DATE	CONTENTS	REVD BY	CHKD BY	CHKD BY	APPD BY

APPD BY	S.Y.KIM	UNIT	inch(mm)	SUBJECT	FR.360 (CAST IRON)	DWG SIZE	A3 (1:2.2)
CHKD BY		SCALE	1/1	TITLE	AUX. TERMINAL BOX ASS'Y	REF. NO	Sheet No. of
CHKD BY	R.G.KIM	PROJEC'N	3rd Angle	DWG NO		3M-165277	Revision No.
DSND BY	배승희	DATE	2024-01-18				

**Cls. I&II, Div. 2
IEEE 841**

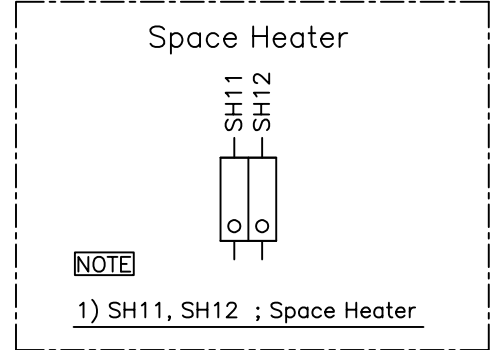
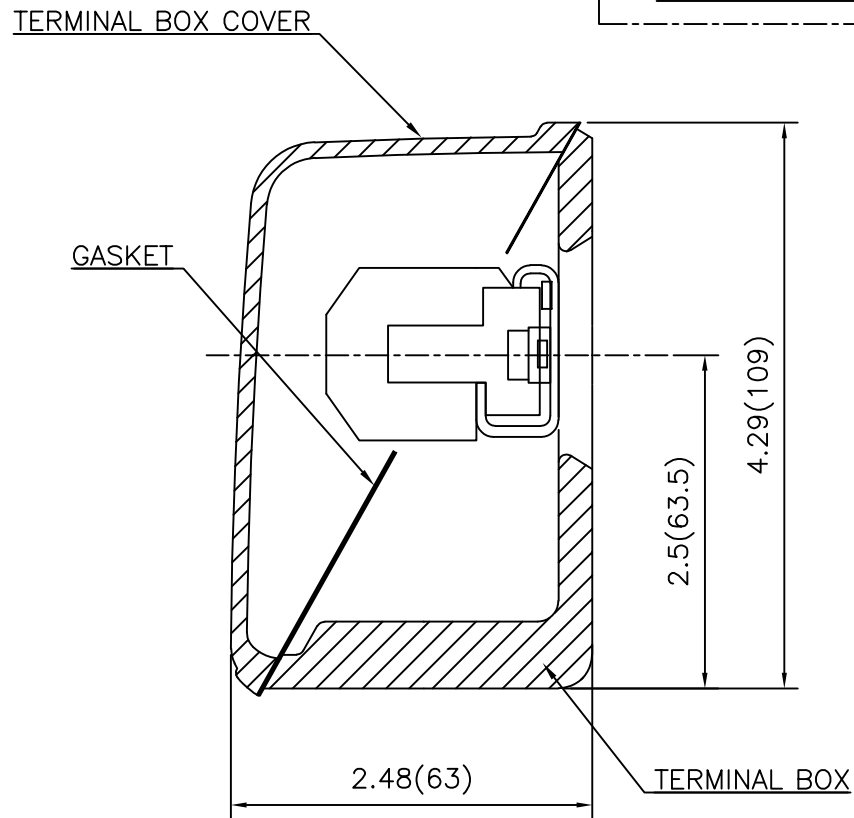

REV	DATE	CONTENTS	REVD BY	CHKD BY	CHKD BY	APPD BY

APPD BY	S.Y.KIM	UNIT	inch(mm)	SUBJECT	FR.180 (CAST IRON)	DWG SIZE
CHKD BY		SCALE	1/1	TITLE	SUB. TERMINAL BOX ASS'Y	A3 (1:1.1)
CHKD BY	R.G.KIM	PROJEC'N	3rd Angle			
DSND BY	배승희	DATE	2024-01-18			
				REF. NO		Sheet No. of
				DWG NO	3M-165277	Revision No. 0