

Customer :
Project Name :
Project No. :
Revision No. :

SPECIFICATION for INDUCTION MOTOR



0		For Bidding			
No.	DATE	DESCRIPTION	PREPARED BY	CHECKED BY	APPROVED BY



AC INDUCTION MOTOR DATA SHEET

Explosion Proof type

Catalog No.	IXHHI10-36-215TC	Item No.		Rev. No.	[]
Project Name		Project No.		Quantity	sets

GENERAL SPECIFICATION		PERFORMANCE DATA			
Frame Size	215TC	Rated Output	7.5 kW		10 HP
Type	XJP	Number of Poles	2		
Enclosure(Protection)	Totally Enclosed / IP55	Rotor Type	Squirrel Cage		
Method of Cooling	IC411(FC)	Starting Method*	D.O.L		
Rated Frequency	60 Hz	Rated Voltage	575 V	460 V	230 V
Number of Phases	3	Current	Full Load	9.71 A	12.13 A
Insulation Class	F		Locked-rotor**	680 %	680 %
Temp. Rise at full load (by resistance method)		Efficiency			
at 1.0 S.F	80 deg. C		50% Load	87.2 %	
Motor Location	<input type="checkbox"/> Indoor <input type="checkbox"/> Outdoor		75% Load	89.2 %	
Altitude	Less than 1,000 meter		100% Load	90.2 %	
Relative Humidity	Less than 80 %	Power Factor(p.u)			
Ambient Temp.	40 deg. C (Max.)		50% Load	0.710	
Duty Type	Continuous (S1)		75% Load	0.810	
Service Factor	1.15		100% Load	0.860	
Mounting	B35	Speed at Full Load	3525 r.p.m		
Bearing	Type	Anti-Friction	Torque		
	DE/N-DE	6307ZZC3 / 6307ZZC3	Full Load	15.0 lb.ft	
	Lubricant	Grease(Polyrex-EM)	Locked-rotor**	160 %	
External Thrust	Not applicable		Breakdown**	260 %	
Coupling Method	<input checked="" type="checkbox"/> Direct <input type="checkbox"/> V-belt	Moment of Inertia (J)			
Shaft Extension	Single		Load(Max.)	11.159 lb.ft2	
Terminal Box	Main	Cast Iron	Motor	0.451 lb.ft2	
	Aux.	No	Sound Pressure Level (No-load & mean value at 1m from motor)		
	Location	Refer to Outline Drawing		76 dB(A)	
Application		Vibration	0.0 mm/sec (peak)		
Area classification	Hazardous	Permissible number of consecutive starts	Cold	0 times	
Type of Ex-Protection	Class I&II, Division 1		Hot	0 times	
Applicable Standard	NEMA MG1, CSA C390, UL674	Paint	Munsell No.	4.0PB5.4/5.5(VL-451)	

ACCESSORIES

*. W.T.D.(Thermostat, 145°C) : 1EA/Ph.

SPARE PARTS

SUBMITTAL DRAWING

Outline Dimension Drawing	Motor Weight(Approx.)	
B35	LM-U0215C4TL001	180 lb.

REMARK

- Premium efficiency according to NEMA MG1
- Inverter Duty @ 1.0 Service Factor & Ambient max 45°C
 - . CT 10.5Hz to 60Hz (10:1 CT at 1hour Duty)
 - . 10:1 VT (20:1 VT at 50% load)
 - . CHP up to 1.5 times base speed, NEMA MG1 Part31
- Class I, Division 1, Group C&D
 - . Temp.Code(Sine wave) : T2C at 40°C Amb./T2B at 55°C Amb. T4 with Winding Temperature Detector
- Class II, Division 1, Group F&G
 - . Temp.Code(Sine wave) : T3B

Date	DSND	CHKD	CHKD	APPD
2024-08-08	S.H. Lee	I.K. Kim	R.G. Kim	S.W. Kim

[Note] Others not mentioned in this data sheet shall be in accordance with maker standard.
 Above technical data are only design values and shall be guaranteed with tolerance of applicable standard.
 Inspection and performance test shall be done according to maker standard, if not mentioned.
 * In case of Inverter-Fed Motor, performance data is based on sine wave tests. It may be different from test data of Inverter combined motor.
 ** Data is based on rated voltage & frequency and is expressed as a percentage of full-load value.

1	2	3	4
REV	DATE	CONTENTS	REVD BY

3.94

CROWN TRITON Premium Efficiency AC 3 Phase Motor Explosion Proof

10HP	2P	230/460V	Cat. No.	IXHHI10-36-215TC		Amb.	40°C
Frame	215TC	Duty	CONT	Amps	24.27/12.1	Type	XJP
RPM	3525	Hertz	60Hz	Encl.	TEFC	Model	LATER
Bearing	Drive	6307ZZC3	S.F.	1.15	on sine wave power	INS. Class	F HD-F1
	Opp.	6307ZZC3	S.F.	1.00	on PWM or IGBT power	NEMA Design	B
Usable at	50Hz 7.5HP 380V 12.7A 2930rpm S.F.: 1.0 Eff.: 87% Code: K						
	50Hz 7.5HP 400/415V 12.5/12.4A 2940/2945rpm S.F.: 1.0 Eff.: 87/87% Code: L/L						
UL Certified for	CLASS I, Div. 1, Gr. C & D / CLASS I, Zone 1, Gr. IIA & IIB					Temp. Code	T2C at 40°C Amb. / T2B at 55°C Amb.
	10:1VT(20:1 at 50% load) CT 10.5Hz to base Hz(10:1 1hour duty at lowest RPM) CHP upto 1.5 time base speed, NEMA MG1 part 31. Amb max 45°C for inverter duty.					T4 With Thermostat	
No.	-		Date	-		Weight	180 lb

4M-136031 (NEMA 182~215Fr.) Made in Korea H1

1.57

APPD BY	S.Y.KIM	UNIT	INCH	SUBJECT	UL Class I, Division1 (IXHHI)	DWG SIZE	A4 (1:1)
CHKD BY	I.K.KIM	SCALE	NONE				
CHKD BY	R.G.KIM	PROJEC'N	3rd Angle	TITLE NAMEPLATE DRAWING			
DSND BY	S.H.LEE	DATE	2024.06.07				
				REF. NO	4M-136031	Sheet No.	of
				DWG NO	NP-IXHHI10-36-215TC	Revision No.	0

Type :	XJP
Full Load Torque :	15.0 lb.ft
Load moment of Inertia (J) :	11.159 lb.ft2
Motor moment of Inertia (J) :	0.451 lb.ft2

7.5kW	10HP	2 P	60 Hz
Speed at Full Load :			3525 RPM
Rated Voltage	575V	460V	230V
Full Load Current	9.7A	12.1A	24.3A

SPEED VS TORQUE & CURRENT CURVE

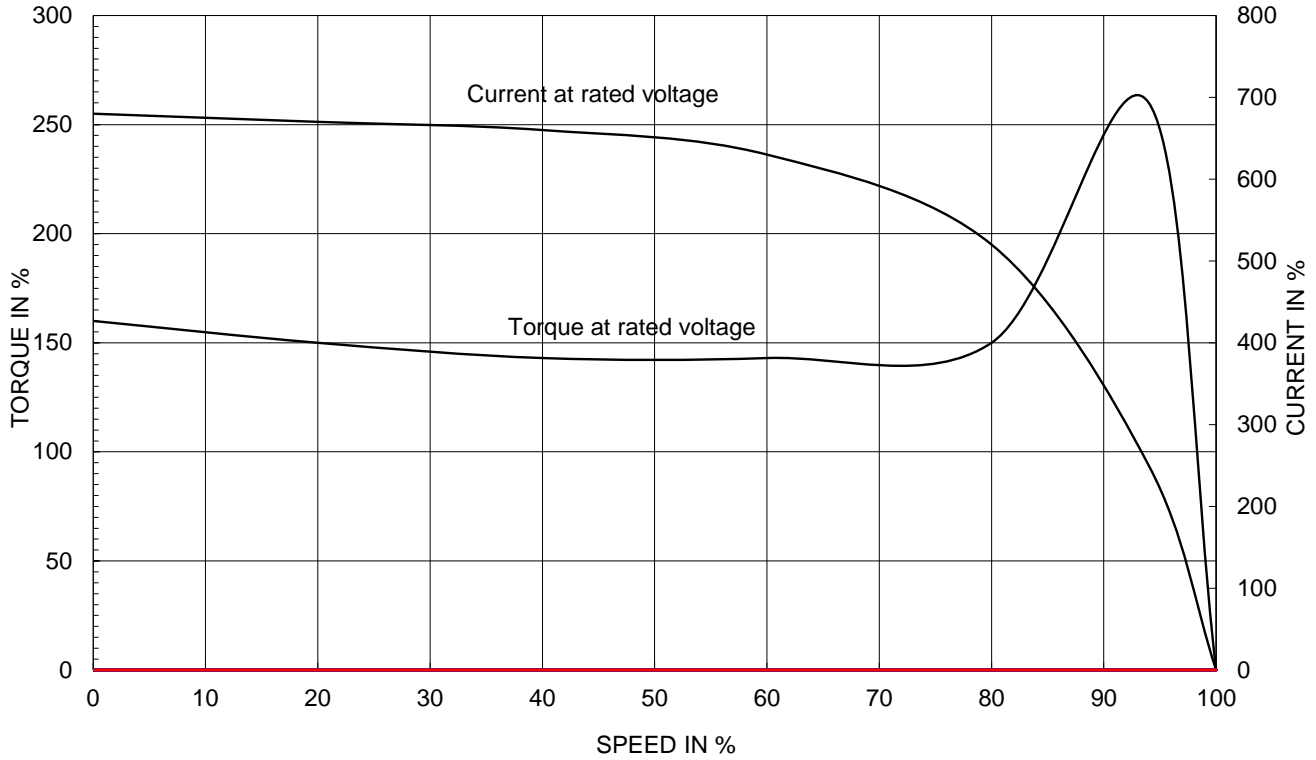

OUTPUT VS EFF., P.F & CURRENT CURVE

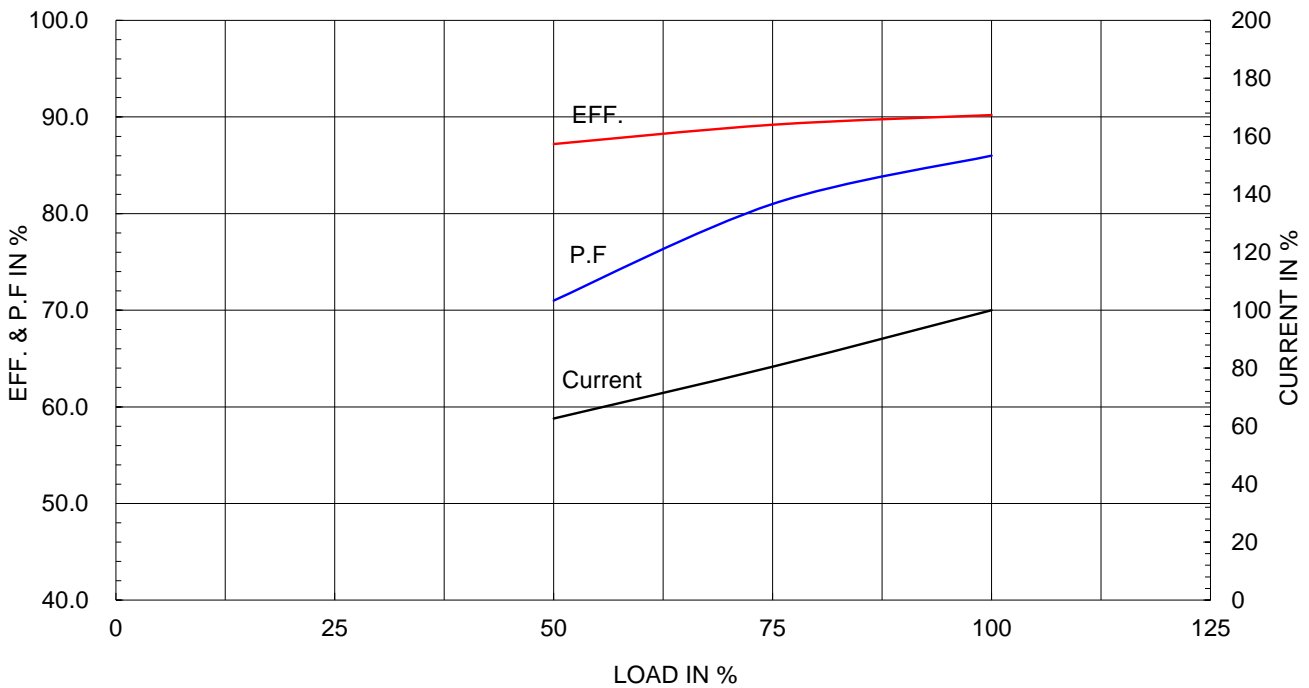

본 도면은 HD현대일렉트릭(주) 재산이며 허가없이 복사할 수 없음 (취급주의)

THIS DRAWING IS PROPRIETARY TO HYUNDAI ELECTRIC. NO PART OF THIS DRAWING MAYBE REPRODUCED WITHOUT THE PERMISSION OF HYUNDAI ELECTRIC.

1	2	3	4
▽	50S	REV	DATE
▽▽	12.5S		
▽▽▽	3.2S		
▽▽▽▽	0.4S		

Class I Division 1

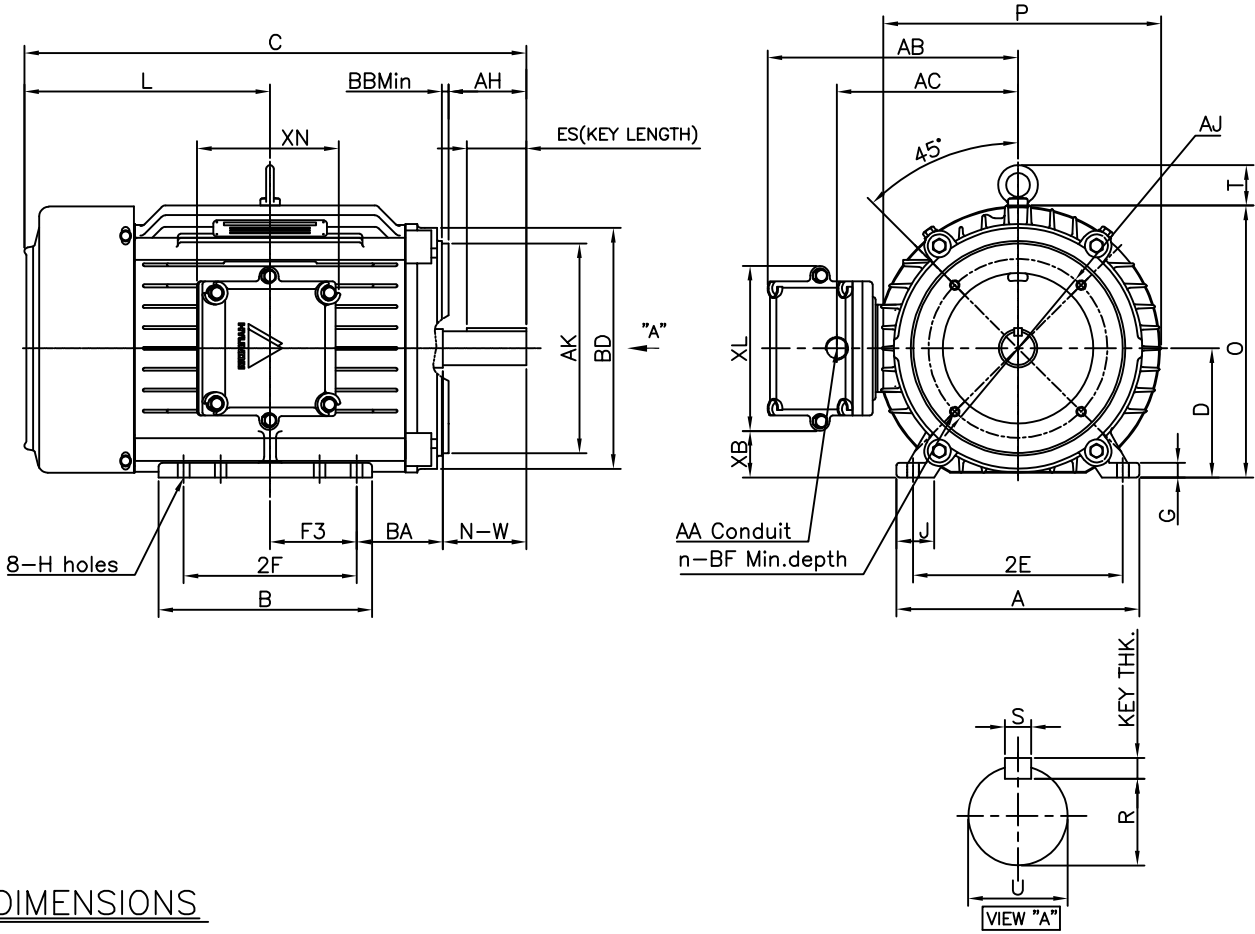

DIMENSIONS

MOUNTING									CONDUIT BOX						APPROX. WGT.(LB)
A	B	2E	-	2F	F3	G	J	H	AA	AB	AC	XB	XL	XN	
9.84	8.66	8.50	-	7.00	3.50	0.60	1.52	0.41	1.00	10.3	7.34	1.88	6.70	5.98	180

OVERALL							SHAFT				KEY	BEARING		
BA	C	D	L	O	P	T	U	N-W	KEYWAY			THK.	DRIVE END	OPP. DRIVE END
									R	ES	S			
3.50	20.36	5.25	9.97	11.02	11.26	1.63	1.375	3.38	1.201	2.41	0.312	0.312	6307ZZC3	6307ZZC3

C-FACE							
AJ	AK	BBmin	BD	BF	BF Def.	n	AH
7.25	8.50	0.25	9.00	1/2-13	0.75	4	3.12

NOTE

- 1.Dimension "D" tolerance : +0.00inch ~ -0.03inch (143TC-365TC) ; +0.000inch ~ -0.06inch (404TC-449TC)
- 2.Dimension "U" tolerance : +0.000inch ~ -0.0005inch (143TC-215TC) ; +0.000inch ~ -0.001inch (254TC-449TC)
- 3.Dimension "R" tolerance : +0.000inch ~ - 0.015inch
- 4.Dimension "AK" tolerance : +0.000inch ~ -0.003inch (143TC-286TC) ; +0.000inch ~ -0.005inch (324TC-449TC)

APPD BY	S.Y.KIM	UNIT	inch	SUBJECT	NEMA 215TC(KIT)	DWG SIZE	
CHKD BY	R.G.KIM	SCALE	1/8	TITLE	OUTLINE	A4 (1:8)	
CHKD BY	J.H.JEON	PROJEC'N	3rd Angle				
DSND BY	J.H.JEON	DATE	2021-06-08				



REF. NO		Sheet No.	of
DWG NO	LM-U0215C4TL001	Revision No.	0



Cls. I Div. 1

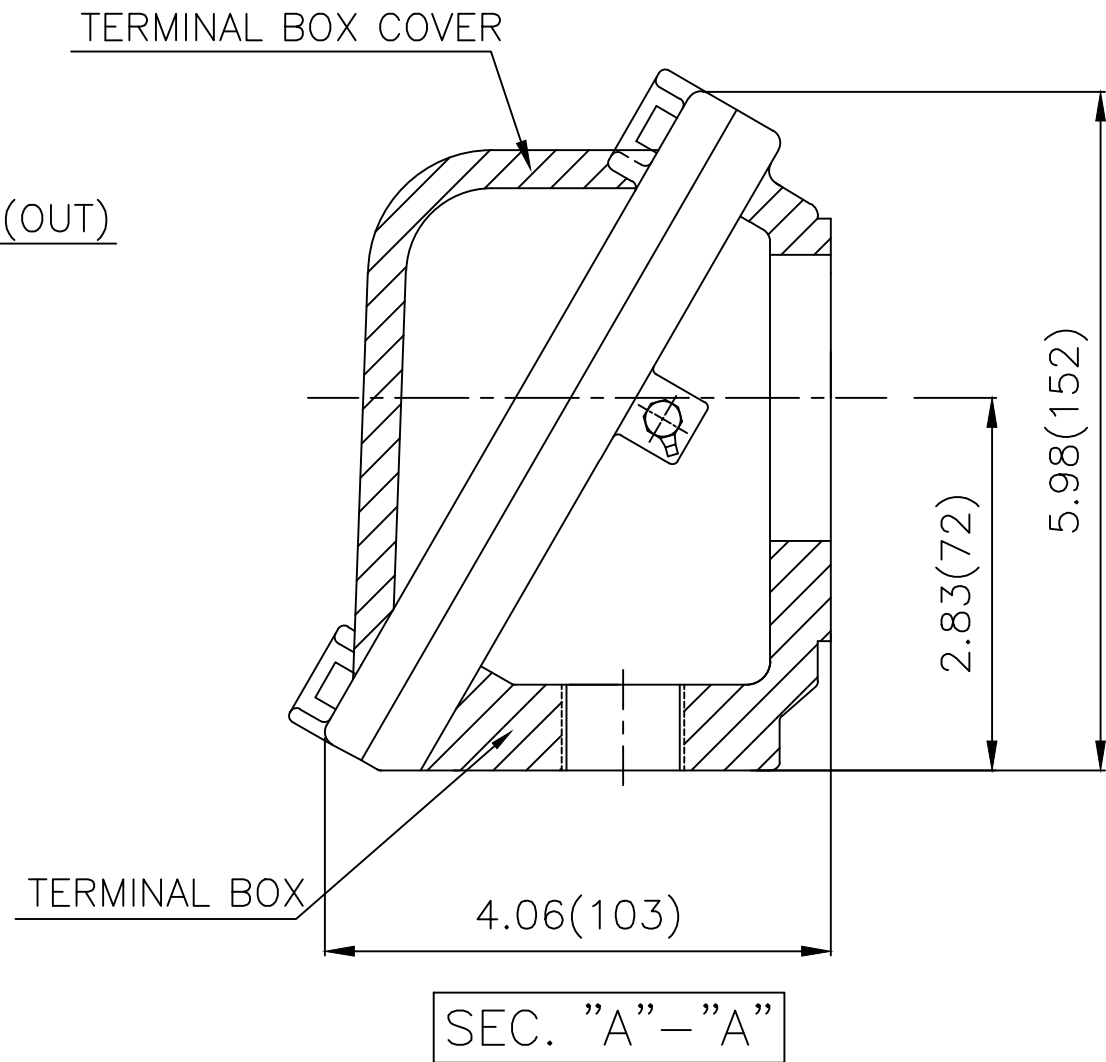
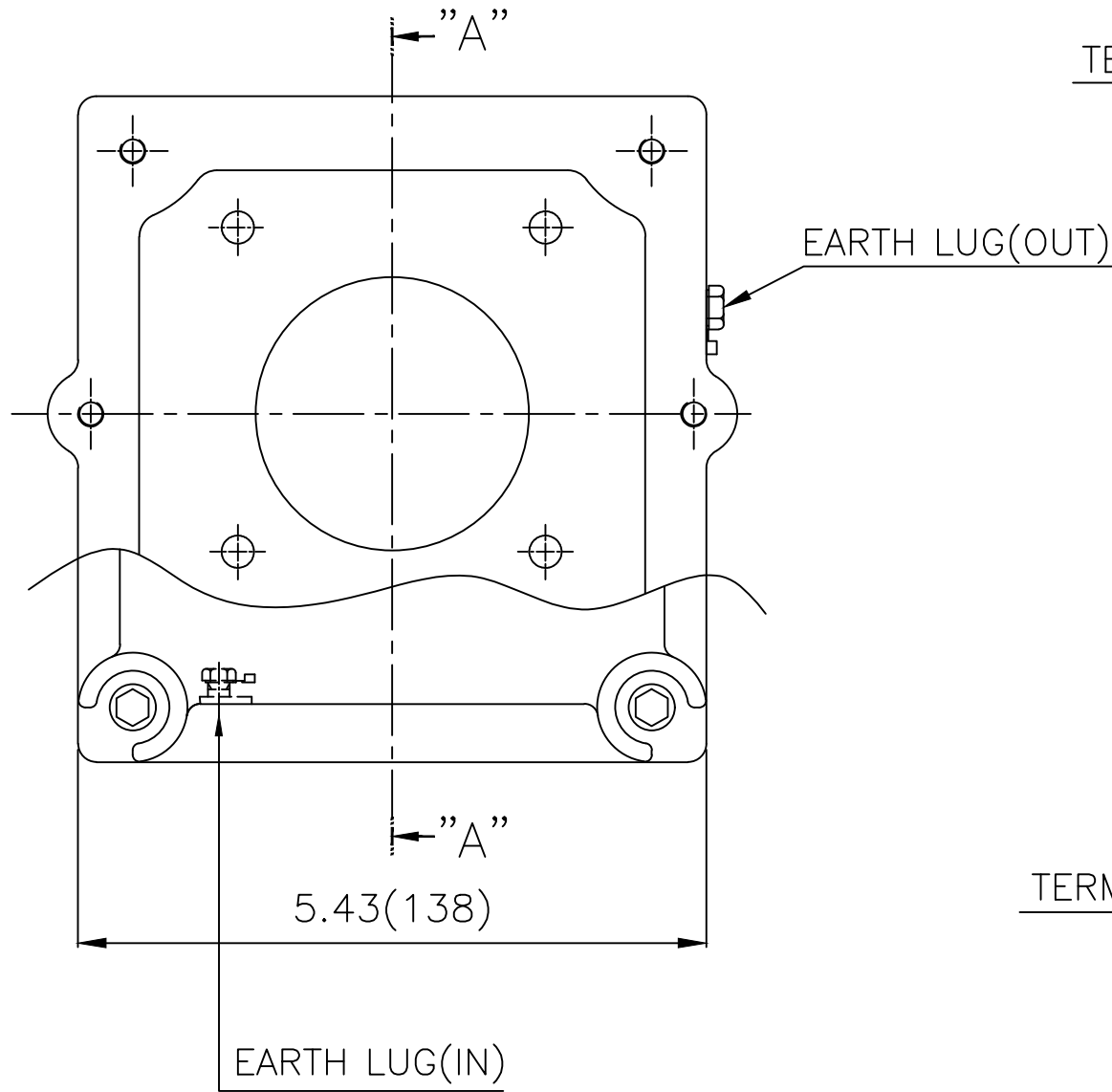

▽	50S
▽▽	12.5S
▽▽▽	3.2S
▽▽▽▽	0.4S

REV	DATE	CONTENTS	REVD BY	CHKD BY	CHKD BY	APPD BY

일반가공공차		일반제관공차	
1-4	±0.1	6-30	±0.5
4-18	±0.2	30-120	±0.8
18-63	±0.3	120-315	±1.2
63-250	±0.5	315-1000	±2.0
250-	±0.8	1000-	±3.0

Q'TY	DESCRIPTION	MATERIAL	DIMENSION	WEIGHT	PART NO.	REMARK	NO.
APPD BY	S.Y.KIM	UNIT	lφφh(mm)	SUBJECT	NEMA FR. 180~210(CAST IRON)	DWG SIZE	A3 (1:1.5)
CHKD BY	R.G.KIM	SCALE	1/1.5	TITLE	MAIN TERMINAL BOX ASS'Y		
CHKD BY		PROJEC'N	3rd Angle	REF. NO		Sheet No.	of
DSND BY	김은진	DATE	2023-10-24	DWG NO	3M-248496	Revision No.	0

