

Customer :
 Project Name :
 Project No. :
 Revision No. :

SPECIFICATION for INDUCTION MOTOR



0		For Bidding			
No.	DATE	DESCRIPTION	PREPARED BY	CHECKED BY	APPROVED BY



AC INDUCTION MOTOR DATA SHEET

IEEE841 TYPE

Catalog No.	IEEE800-36-5812S-IBBRSRSHSP	Item No.		Rev. No.	[]
Project Name		Project No.		Quantity	sets

GENERAL SPECIFICATION			PERFORMANCE DATA			
Frame Size	5812S		Rated Output	600 kW		800 HP
Type	HNE6		Number of Poles	2		
Enclosure(Protection)	Totally Enclosed	/ IP55	Rotor Type	Squirrel Cage		
Method of Cooling	IC411(FC)		Starting Method*	D.O.L		
Rated Frequency	60 Hz		Rated Voltage	575 V	460 V	230 V
Number of Phases	3		Current	Full Load	706.6 A	883.2 A
Insulation Class	F			Locked-rotor**	650 %	650 %
Temp. Rise at full load (by resistance method)			Efficiency			
at 1.0 S.F	80 deg. C		50% Load		92.8 %	
Motor Location	<input type="checkbox"/> Indoor <input type="checkbox"/> Outdoor		75% Load		94.8 %	
Altitude	Less than 1,000 meter		100% Load		95.8 %	
Relative Humidity	Less than 80 %		Power Factor(p.u)			
Ambient Temp.	40 deg. C (Max.)		50% Load		0.740	
Duty Type	Continuous (S1)		75% Load		0.840	
Service Factor	1.15		100% Load		0.890	
Mounting	B3		Speed at Full Load	3570 r.p.m		
Bearing	Type	Anti-Friction	Torque			
	DE/N-DE	6316C3 / 6316C3-INS.	Full Load	1,184.0 lb.ft		
	Lubricant	Grease(Polyrex-EM)	Locked-rotor**	130 %		
External Thrust	Not applicable		Breakdown**	240 %		
Coupling Method	<input checked="" type="checkbox"/> Direct <input type="checkbox"/> V-belt		Moment of Inertia (J)			
Shaft Extension	Single		Load(Max.)	574.869 lb.ft2		
Terminal Box	Main	Steel	Motor	121.840 lb.ft2		
	Aux.	Yes	Sound Pressure Level (No-load & mean value at 1m from motor)			
	Location	Refer to Outline Drawing	89 dB(A)			
Application			Vibration			
Area classification	Hazardous		3.8 mm/sec (peak)			
Type of Ex-Protection	Class I, Division 2		Permissible number of consecutive starts	Cold	2 times	
Applicable Standard	IEEE841, NEMA MG1, CSA C390		Hot	1 time		
			Paint	Munsell No.	7.5BG6/1.5	

ACCESSORIES	
*	B.T.D.(Pt 100 Ω at 0°C,Single) : 2EA/Motor
*	W.T.D.(Pt 100 Ω at 0°C) : 2EA/Ph.
*	Space Heater : 1EA/Motor

SPARE PARTS	
1.	Spare Axial Fan (C.W Direction)

SUBMITTAL DRAWING			
Outline Dimension Drawing		Motor Weight(Approx.)	
B3	LM-I5812B3C7001	6730 lb.	

REMARK				
1. Premium efficiency according to NEMA MG1				
2. Inverter Duty @ 1.0 Service Factor & F Temperature rise				
- 10:1 VT				
- 2:1 CT				
3. NDE side : Insulated bearing				
4. CSA Certification				
- Class I, Division 2, Group A, B, C & D; Temp code : T3A				
5. Shaft material : AISI4140				
6. Uni-directional CCW viewed from drive end.				

Date	DSND	CHKD	CHKD	APPD
2024-09-22	E.J.LEE	I.K. Kim	R.G. Kim	S.W. Kim

[Note] Others not mentioned in this data sheet shall be in accordance with maker standard.
 Above technical data are only design values and shall be guaranteed with tolerance of applicable standard.
 Inspection and performance test shall be done according to maker standard, if not mentioned.
 * In case of Inverter-Fed Motor, performance data is based on sine wave tests. It may be different from test data of Inverter combined motor.
 ** Data is based on rated voltage & frequency and is expressed as a percentage of full-load value.

1		2		3		4																																																																																																						
REV	DATE	CONTENTS				REVD BY	CHKD BY	CHKD BY	APPD BY																																																																																																			
4.72																																																																																																												
<div style="border: 1px solid black; padding: 10px;"> <p style="text-align: center;">CROWN TRITON Premium Efficiency AC 3 Phase Motor</p> <div style="display: flex; justify-content: space-between;"> </div> <table border="1" style="width: 100%; border-collapse: collapse;"> <tr> <td>800HP</td> <td>2P</td> <td>460V</td> <td colspan="2">Cat. No. IEEE800-36-5812S-IBBRSRSHSP</td> </tr> <tr> <td>Model</td> <td>LATER</td> <td></td> <td>INS. Class</td> <td>F</td> <td>Amps</td> <td>883.2</td> </tr> <tr> <td>Type</td> <td>HNE6</td> <td>Duty</td> <td>CONT</td> <td>Code</td> <td>G</td> <td>Amb.</td> <td>40°C</td> <td>Hertz</td> <td>60Hz</td> </tr> <tr> <td>Frame</td> <td>5812S</td> <td>Encl.</td> <td>TEFC</td> <td>S.F.</td> <td>1.15</td> <td>RPM</td> <td>3570</td> <td>NEMA Norm. Eff.</td> <td>95.8%</td> </tr> <tr> <td rowspan="2">Bearing</td> <td>Drive</td> <td colspan="2">6316C3</td> <td colspan="2">S.F.1.00 (2:1 C.T., 10:1 V.T., NEMA-MG1 Part31)</td> <td colspan="2">3/4 Eff.</td> <td colspan="2">94.8%</td> </tr> <tr> <td>Opp.</td> <td colspan="2">6316C3-INS.</td> <td colspan="2"></td> <td colspan="2">NEMA Design</td> <td colspan="2">B Torque</td> </tr> <tr> <td rowspan="2">Usable at</td> <td colspan="9">50Hz 600HP 380V 811A 2970rpm S.F.: 1.15 Eff.: 95.8% Code: G</td> </tr> <tr> <td colspan="9">50Hz 600HP 400/415V 770.45/751.06A 2972/2975rpm S.F.: 1.15 Eff.: 95.8/95.81% Code: H/J</td> </tr> <tr> <td rowspan="2">CSA Certified for</td> <td colspan="4">CLASS I, Div. 2, Gr. A, B, C & D</td> <td colspan="2">Temp. Code (sine wave)</td> <td>Frame</td> <td colspan="2">580FR</td> </tr> <tr> <td colspan="4"></td> <td colspan="2"></td> <td>Maximum Amb.</td> <td colspan="2">50°C T3A (180°C)</td> </tr> <tr> <td>No.</td> <td colspan="3">-</td> <td>Date</td> <td colspan="2">-</td> <td>Weight</td> <td colspan="2">6730 lb</td> </tr> </table> <p style="text-align: center;">IEEE Std 841-2021 4M-136445</p> <p style="text-align: center;">Made in Korea H1</p> <div style="text-align: right;"> </div> </div>										800HP	2P	460V	Cat. No. IEEE800-36-5812S-IBBRSRSHSP		Model	LATER		INS. Class	F	Amps	883.2	Type	HNE6	Duty	CONT	Code	G	Amb.	40°C	Hertz	60Hz	Frame	5812S	Encl.	TEFC	S.F.	1.15	RPM	3570	NEMA Norm. Eff.	95.8%	Bearing	Drive	6316C3		S.F.1.00 (2:1 C.T., 10:1 V.T., NEMA-MG1 Part31)		3/4 Eff.		94.8%		Opp.	6316C3-INS.				NEMA Design		B Torque		Usable at	50Hz 600HP 380V 811A 2970rpm S.F.: 1.15 Eff.: 95.8% Code: G									50Hz 600HP 400/415V 770.45/751.06A 2972/2975rpm S.F.: 1.15 Eff.: 95.8/95.81% Code: H/J									CSA Certified for	CLASS I, Div. 2, Gr. A, B, C & D				Temp. Code (sine wave)		Frame	580FR								Maximum Amb.	50°C T3A (180°C)		No.	-			Date	-		Weight	6730 lb	
800HP	2P	460V	Cat. No. IEEE800-36-5812S-IBBRSRSHSP																																																																																																									
Model	LATER		INS. Class	F	Amps	883.2																																																																																																						
Type	HNE6	Duty	CONT	Code	G	Amb.	40°C	Hertz	60Hz																																																																																																			
Frame	5812S	Encl.	TEFC	S.F.	1.15	RPM	3570	NEMA Norm. Eff.	95.8%																																																																																																			
Bearing	Drive	6316C3		S.F.1.00 (2:1 C.T., 10:1 V.T., NEMA-MG1 Part31)		3/4 Eff.		94.8%																																																																																																				
	Opp.	6316C3-INS.				NEMA Design		B Torque																																																																																																				
Usable at	50Hz 600HP 380V 811A 2970rpm S.F.: 1.15 Eff.: 95.8% Code: G																																																																																																											
	50Hz 600HP 400/415V 770.45/751.06A 2972/2975rpm S.F.: 1.15 Eff.: 95.8/95.81% Code: H/J																																																																																																											
CSA Certified for	CLASS I, Div. 2, Gr. A, B, C & D				Temp. Code (sine wave)		Frame	580FR																																																																																																				
							Maximum Amb.	50°C T3A (180°C)																																																																																																				
No.	-			Date	-		Weight	6730 lb																																																																																																				
2.36																																																																																																												
A																																																																																																												
APPD BY	S.Y.KIM	UNIT	INCH	SUBJECT	CSA Class I, Division2 IEEEB41 (XL)				DWG SIZE																																																																																																			
CHKD BY	I.K.KIM	SCALE	NONE	TITLE NAMEPLATE DRAWING					A4 (1:1)																																																																																																			
CHKD BY	R.G.KIM	PROJEC'N	3rd Angle																																																																																																									
DSND BY	S.H.LEE	DATE	2024.06.07																																																																																																									
				REF. NO	4M-136445		Sheet No. of																																																																																																					
				DWG NO	NP-IEEE800-36-5812S-IBBRSRSHSP		Revision No. 0																																																																																																					
1		2		3		4		A																																																																																																				



PERFORMANCE CURVE

CURVE NO.
PC-IEEE800-36-5812S-IBBRSRSHSP

Type :	HNE6	
Full Load Torque :	1184.0	lb.ft
Load moment of Inertia (J) :	574.869	lb.ft2
Motor moment of Inertia (J) :	121.840	lb.ft2

600kW	800HP	2 P	60 Hz
Speed at Full Load :			3570 RPM
Rated Voltage	575V	460V	230V
Full Load Current	706.6A	883.2A	1766.5A

SPEED VS TORQUE & CURRENT CURVE

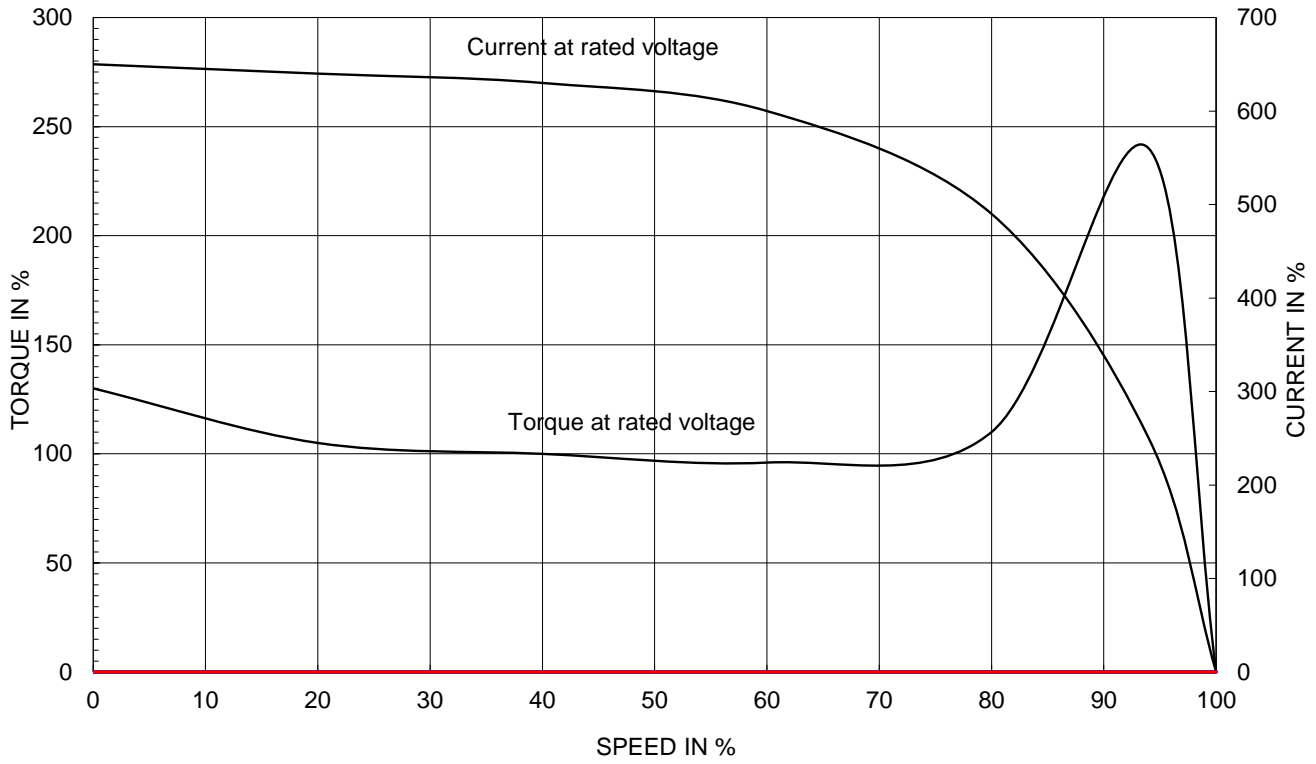

OUTPUT VS EFF., P.F & CURRENT CURVE

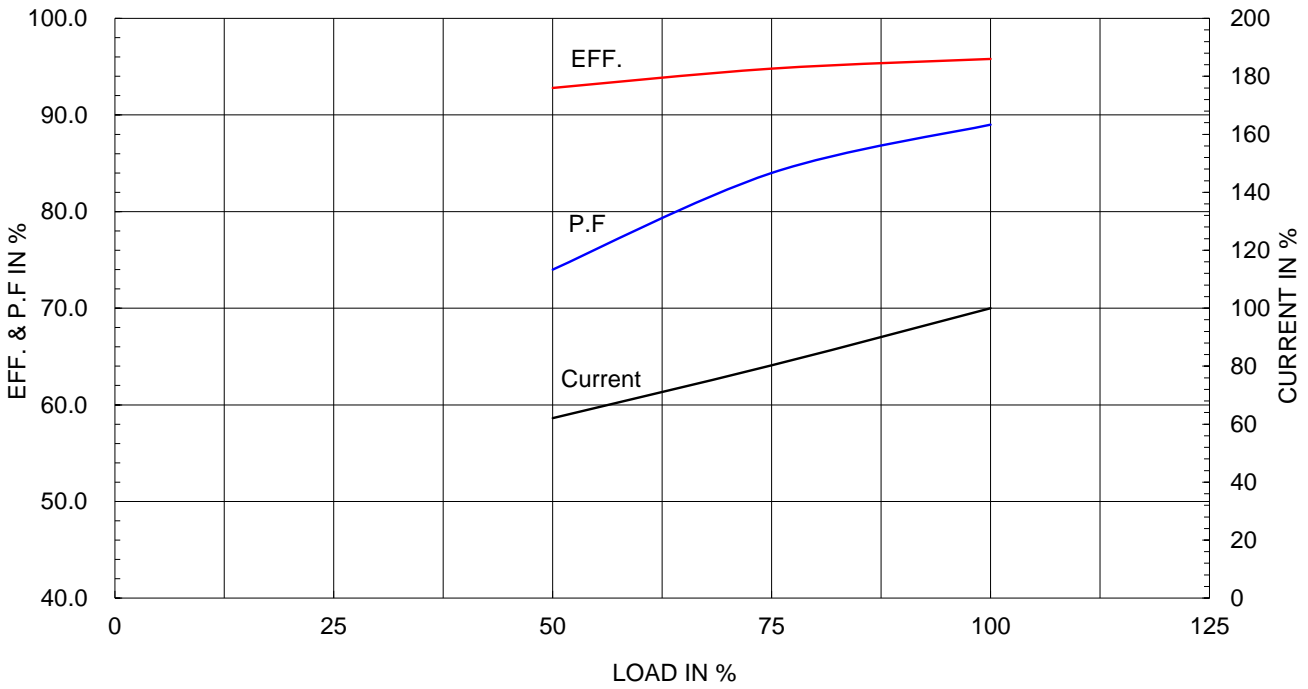

THIS DRAWING IS PROPRIETARY TO HYUNDAI ELECTRIC. NO PART OF THIS DRAWING MAY BE REPRODUCED WITHOUT THE PERMISSION OF HYUNDAI ELECTRIC.

본 도면은 HD현대일렉트릭(주) 재산이며 허가없이 복사할 수 없음 (취급주의)

IEEE841

APPROX.82.04"(2084)

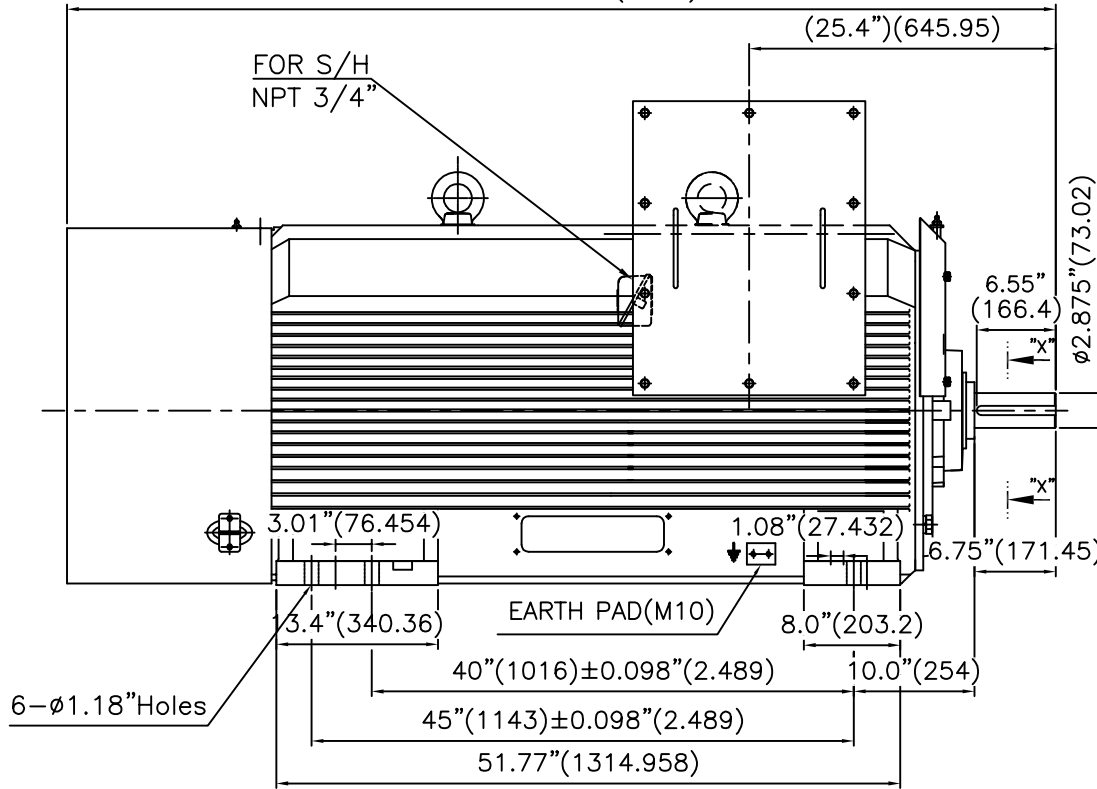

TECHNICAL INFORMATION

1) BEARING & LUBRICANT LIST

BEARING	Drive End	Non-Drive End
Bearing Type	6316C3	6316C3
Lubricant Type	GREASE	GREASE
Grease Type	Mobil(Polyrex-EM)	Mobil(Polyrex-EM)
Initial Charge Quantity	200 g	200 g
Mark-Up	Quantity	33 g
	Interval	2 MONTHS

2) TOLERANCE :

CENTER HEIGHT	14.5	+0.000	-0.060
SHAFT DIAMETER	ø2.875	+0.000	-0.001
KEYWAY WIDTH	0.75	+0.003	-0.000

APPROX.51.87"(1318)

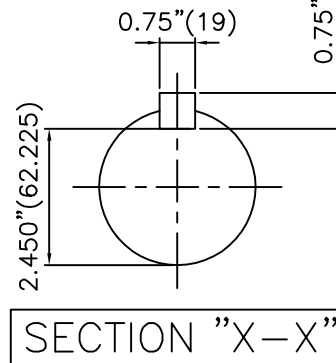
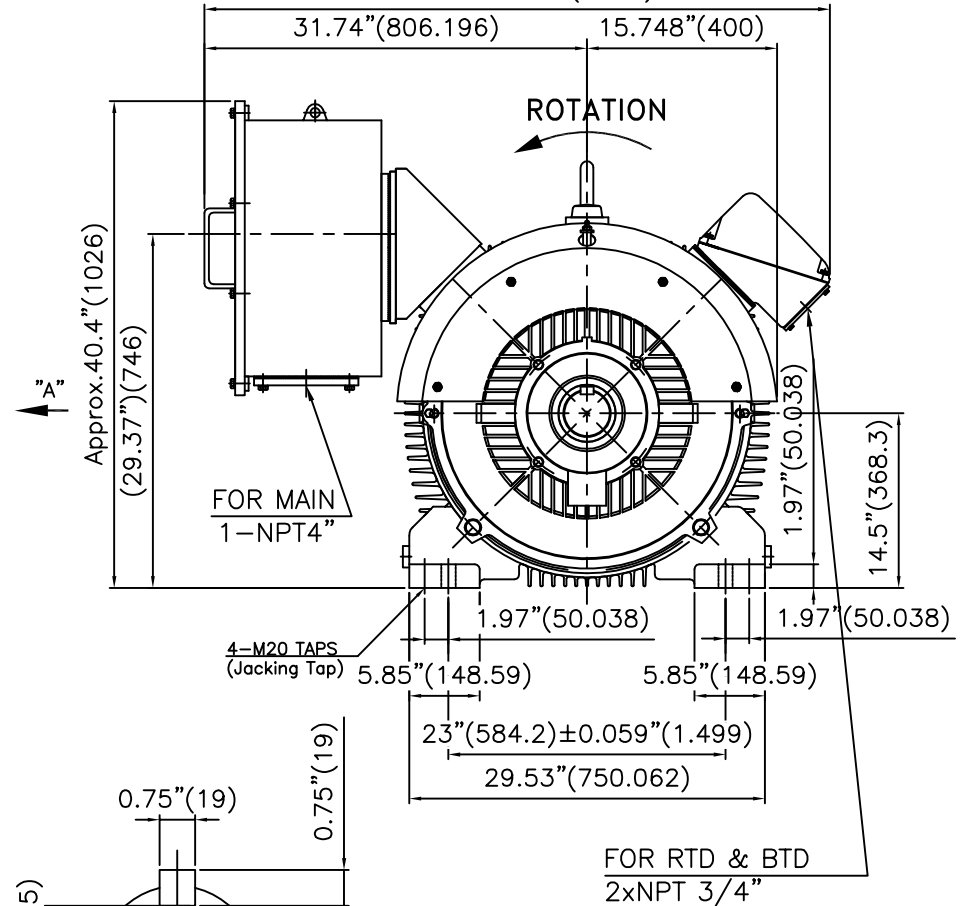

VIEW "A"

Q'TY	DESCRIPTION	MATERIAL	DIMENSION	WEIGHT	PART NO.	REMARK
APPD BY	S.K.HAN	UNIT	INCH(MM)	SUBJECT	Fr.5812-2P	
CHKD BY	S.Y.KIM	SCALE	1/12	TITLE	OUTLINE	
CHKD BY	R.G.KIM	PROJEC'N	3각법 (3rd Angle)	REF. NO		Sheet No. of
DSND BY	M.S.HA	DATE	2019.05.16	DWG NO	LM-I5812B3C7001	Revision No.

REV	DATE	CONTENTS	REVD BY	CHKD BY	CHKD BY	APPD BY
1						
2						
3						
4						

**Cls. I&II, Div. 2
IEEE 841**

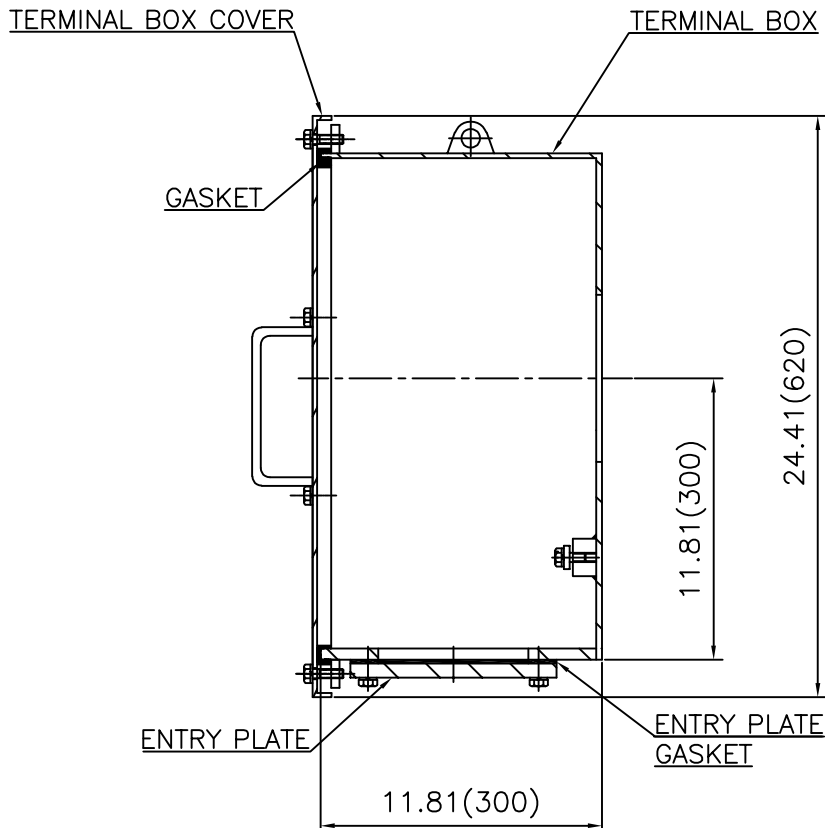
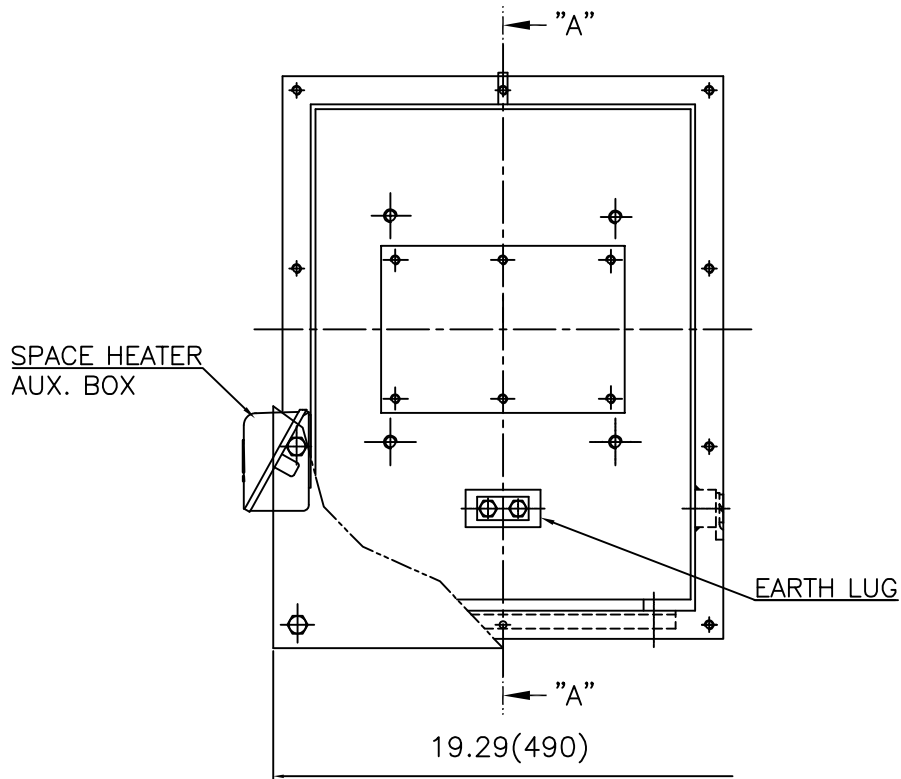

SEC. "A" - "A"

REV	DATE	CONTENTS	REVD BY	CHKD BY	CHKD BY	APPD BY
1						
2						
3						
4						

APPD BY	S.Y.KIM	UNIT	inch(mm)	SUBJECT	FR.580 (STEEL)	DWG SIZE	A3 (1:6)
CHKD BY		SCALE	1/6	TITLE	MAIN TERMINAL BOX ASS'Y		
CHKD BY	R.G.KIM	PROJEC'N	3rd Angle	REF. NO		Sheet No.	of
DSND BY	박승희	DATE	2023-10-25	DWG NO	3M-248512	Revision No.	0



Cls. I&II, Div. 2

IEEE 841

본 도면은 HD현대일렉트릭(주) 재산이며
허가없이 복사할 수 없음 (취급주의)

THIS DRAWING IS PROPRIETARY TO HYUNDAI ELECTRIC. NO PART OF THIS DRAWING
MAY BE REPRODUCED WITHOUT THE PERMISSION OF HYUNDAI ELECTRIC.

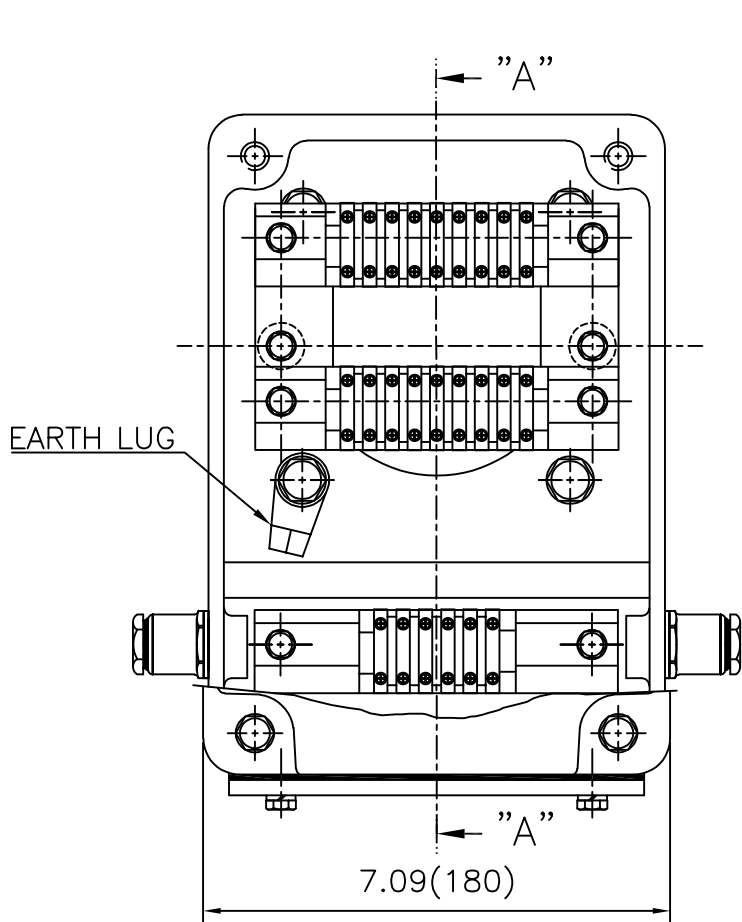

REV	DATE	CONTENTS	REVD BY	CHKD BY	CHKD BY	APPD BY

APPD BY	S.Y.KIM	UNIT	inch(mm)	SUBJECT	FR.360 (CAST IRON)	DWG SIZE	A3 (1:2.2)
CHKD BY		SCALE	1/1	TITLE	AUX. TERMINAL BOX ASS'Y	REF. NO	Sheet No. of
CHKD BY	R.G.KIM	PROJEC'N	3rd Angle	DWG NO		3M-165277	Revision No.
DSND BY	박승희	DATE	2024-01-18				

**Cls. I&II, Div. 2
IEEE 841**



REV	DATE	CONTENTS	REVD BY	CHKD BY	CHKD BY	APPD BY

APPD BY	S.Y.KIM	UNIT	inch(mm)	SUBJECT	FR.180 (CAST IRON)	DWG SIZE	A3 (1:1.1)
CHKD BY		SCALE	1/1	TITLE	SUB. TERMINAL BOX ASS'Y		
CHKD BY	R.G.KIM	PROJEC'N	3rd Angle	REF. NO		Sheet No.	of
DSND BY	배승희	DATE	2024-01-18	DWG NO	3M-165278	Revision No.	0

