

Customer :
Project Name :
Project No. :
Revision No. :

SPECIFICATION for INDUCTION MOTOR



0		For Bidding			
No.	DATE	DESCRIPTION	PREPARED BY	CHECKED BY	APPROVED BY



AC INDUCTION MOTOR DATA SHEET

Explosion Proof type

Catalog No.	IXHHI10-12-256T	Item No.		Rev. No.	[]
Project Name		Project No.		Quantity	sets

GENERAL SPECIFICATION		PERFORMANCE DATA			
Frame Size	256T	Rated Output	7.5 kW 10 HP		
Type	XJP	Number of Poles	6		
Enclosure(Protection)	Totally Enclosed / IP55	Rotor Type	Squirrel Cage		
Method of Cooling	IC411(FC)	Starting Method*	D.O.L		
Rated Frequency	60 Hz	Rated Voltage	575 V	460 V	230 V
Number of Phases	3	Current	Full Load	11.03 A	13.79 A
Insulation Class	F		Locked-rotor**	680 %	680 %
Temp. Rise at full load (by resistance method)		Efficiency			
at 1.0 S.F	80 deg. C		50% Load	88.0 %	
Motor Location	<input type="checkbox"/> Indoor <input type="checkbox"/> Outdoor		75% Load	90.0 %	
Altitude	Less than 1,000 meter		100% Load	91.0 %	
Relative Humidity	Less than 80 %	Power Factor(p.u)			
Ambient Temp.	40 deg. C (Max.)		50% Load	0.600	
Duty Type	Continuous (S1)		75% Load	0.700	
Service Factor	1.15		100% Load	0.750	
Mounting	B3	Speed at Full Load	1175 r.p.m		
Bearing	Type	Anti-Friction	Torque		
	DE/N-DE	6309ZC3 / 6309ZC3	Full Load	45.0 lb.ft	
	Lubricant	Grease(Polyrex-EM)	Locked-rotor**	170 %	
External Thrust	Not applicable		Breakdown**	250 %	
Coupling Method	<input checked="" type="checkbox"/> Direct <input type="checkbox"/> V-belt	Moment of Inertia (J)			
Shaft Extension	Single		Load(Max.)	173.035 lb.ft2	
Terminal Box	Main	Cast Iron	Motor	3.086 lb.ft2	
	Aux.	No	Sound Pressure Level (No-load & mean value at 1m from motor)	64 dB(A)	
Location	Refer to Outline Drawing	Vibration	0.0 mm/sec (peak)		
Application		Permissible number of consecutive starts	Cold	0 times	
Area classification	Hazardous		Hot	0 times	
Type of Ex-Protection	Class I&II, Division 1	Paint	Munsell No.	4.0PB5.4/5.5(VL-451)	
Applicable Standard	NEMA MG1, CSA C390, UL674				

ACCESSORIES

*. W.T.D.(Thermostat, 145°C) : 1EA/Ph.

SPARE PARTS

SUBMITTAL DRAWING

Outline Dimension Drawing	Motor Weight(Approx.)
B3	LM-U0256B3TL001 350 lb.

REMARK

- Premium efficiency according to NEMA MG1
- Inverter Duty @ 1.0 Service Factor & Ambient max 45°C
 - 4:1 CT (10:1 CT at 1hour Duty)
 - 10:1 VT (20:1 VT at 50% load)
 - CHP up to 1.5 times base speed, NEMA MG1 Part31
- Class I, Division 1, Group C&D
 - Temp.Code(Sine wave) : T2D at 40°C Amb./T2C at 55°C Amb. T4 with Winding Temperature Detector
- Class II, Division 1, Group F&G
 - Temp.Code(Sine wave) : T3B

Date	DSND	CHKD	CHKD	APPD
2024-08-08	S.H. Lee	I.K. Kim	R.G. Kim	S.W. Kim

[Note] Others not mentioned in this data sheet shall be in accordance with maker standard.
 Above technical data are only design values and shall be guaranteed with tolerance of applicable standard.
 Inspection and performance test shall be done according to maker standard, if not mentioned.
 * In case of Inverter-Fed Motor, performance data is based on sine wave tests. It may be different from test data of Inverter combined motor.
 ** Data is based on rated voltage & frequency and is expressed as a percentage of full-load value.

1	2	3	4
REV	DATE	CONTENTS	REVD BY

4.72

CROWN TRITON
Premium Efficiency AC 3 Phase Motor

Explosion Proof







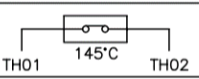

10HP	6P	230/460V	Cat. No.	IXHHI10-12-256T	Amps	27.58/13.		
Model	LATER		INS. Class	F HD-F1	Hertz	60Hz		
Type	XJP	Duty	CONT	Code	J	NEMA Nom. Eff.	91%	
Frame	256T	Encl.	TEFC	S.F.	1.15	on sine wave power	3/4 Eff. 90%	
Bearing	Drive	6309ZC3		S.F.	1.00	on PWM or IGBT power	NEMA Design	B Torque
	Opp.	6309ZC3		RPM	1175		Amb.	40°C
Usable at	50Hz 7.5HP 380V 14.8A 980rpm S.F.: 1.0 Eff.: 86% Code: K							
	50Hz 7.5HP 400/415V 15.1/15.6A 980/980rpm S.F.: 1.0 Eff.: 86/86% Code: L/L							
UL Certified for	Class I, Div. 1, Group C&D / Class I, Zone 1, Group II A & II B				Temp. Code	T2D at 40°C Amb. / T2C at 55°C Amb.		
	10:1VT(20:1 at 50% load) 4:1CT(10:1 1hour duty at lowest RPM)					T4 With Thermostat		
No.	-			Date	-		Weight	350 lb

4M-136066
(NEMA 250~280Fr.)

Made in Korea H1



2.36

APPD BY	S.Y.KIM	UNIT	INCH	SUBJECT	UL Class I, Division1 (IXHHI)	DWG SIZE
CHKD BY	I.K.KIM	SCALE	NONE			A4 (1:1)
CHKD BY	R.G.KIM	PROJEC'N	3rd Angle	TITLE NAMEPLATE DRAWING		
DSND BY	S.H.LEE	DATE	2024.06.07			
				REF. NO	4M-136066	Sheet No. of
				DWG NO	NP-IXHHI10-12-256T	Revision No. 0

Type :	XJP
Full Load Torque :	45.0 lb.ft
Load moment of Inertia (J) :	173.035 lb.ft ²
Motor moment of Inertia (J) :	3.086 lb.ft ²

7.5kW	10HP	6 P	60 Hz
Speed at Full Load :			1175 RPM
Rated Voltage	575V	460V	230V
Full Load Current	11.0A	13.8A	27.6A

SPEED VS TORQUE & CURRENT CURVE

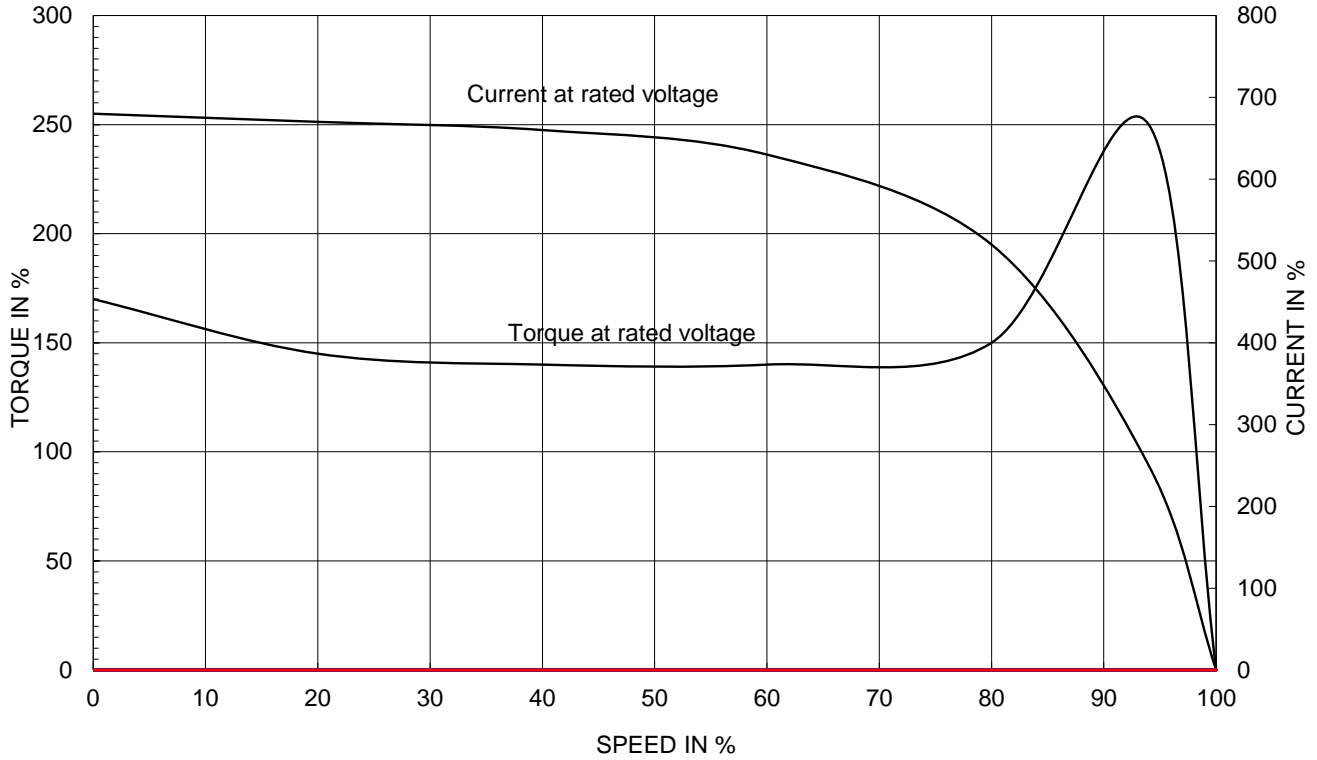

OUTPUT VS EFF., P.F & CURRENT CURVE

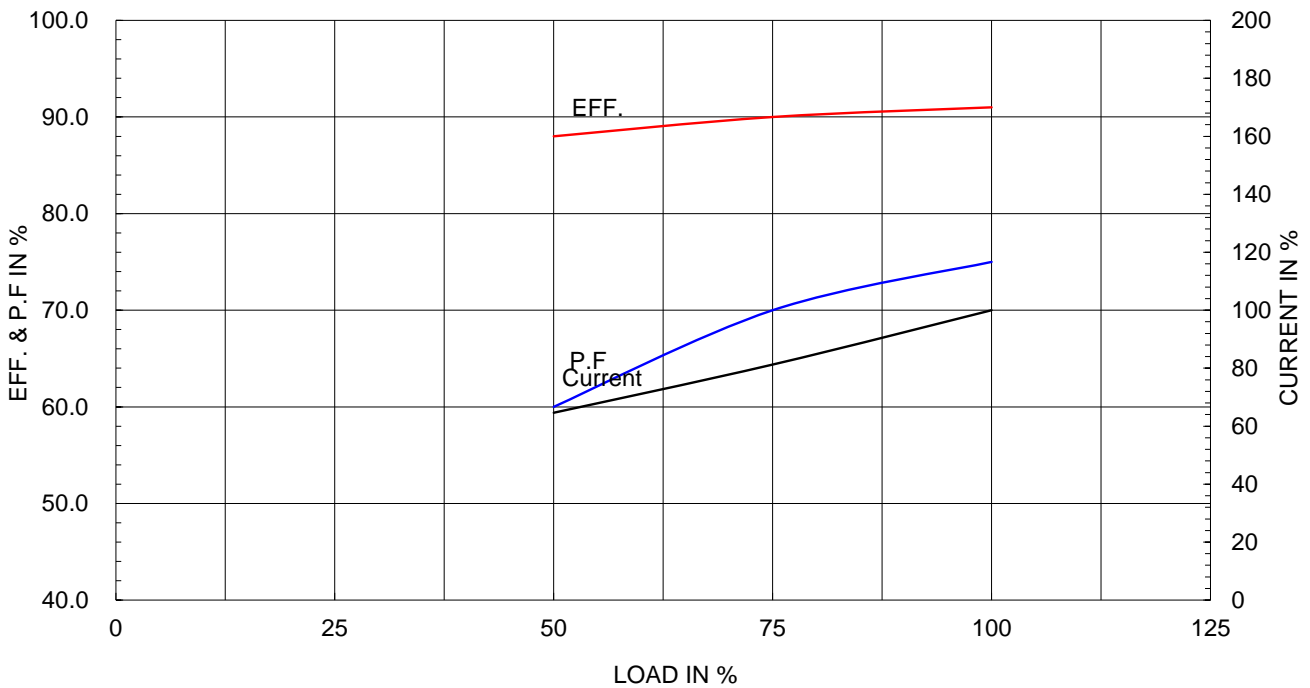

본 도면은 HD현대일렉트릭(주) 재산이며 허가없이 복사할 수 없음 (최급유위)

THIS DRAWING IS PROPRIETARY TO HYUNDAI ELECTRIC. NO PART OF THIS DRAWING MAYBE REPRODUCED WITHOUT THE PERMISSION OF HYUNDAI ELECTRIC.

1	2	3	4
▽	50S	REV	DATE
▽▽	12.5S		
▽▽▽	3.2S		
▽▽▽▽	0.4S		

Class I Division 1

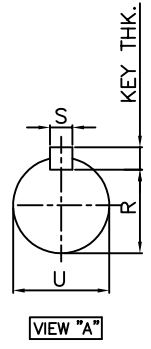
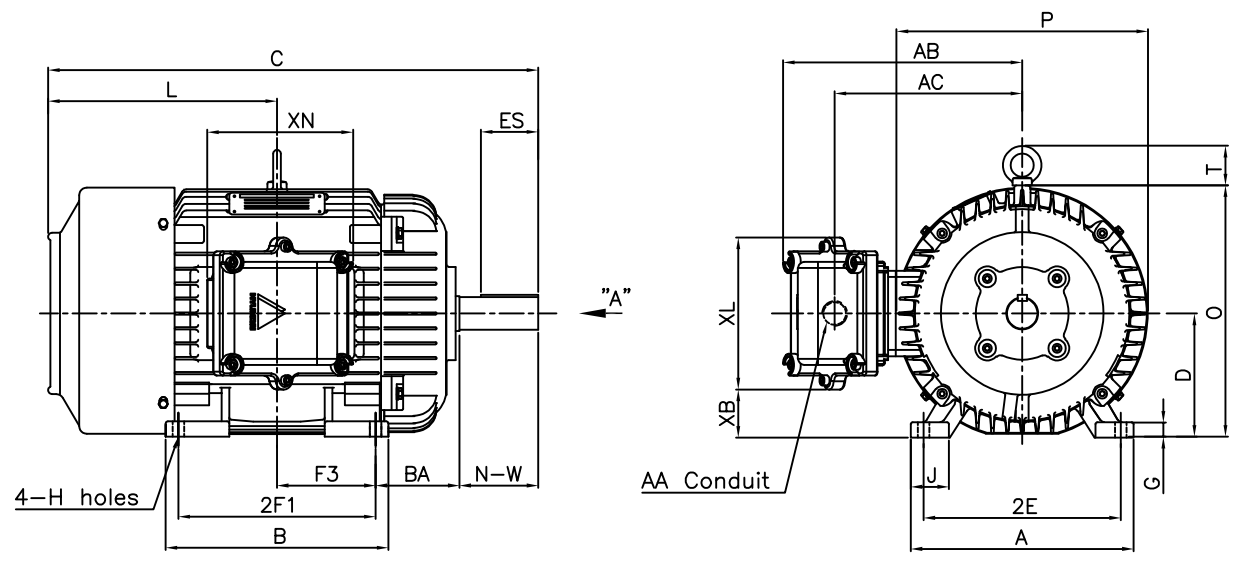

DIMENSIONS

MOUNTING									CONDUIT BOX						APPROX. WGT.(LB)
A	B	2E	2F1	2F2	F3	G	J	H	AA	AB	AC	XB	XL	XN	
11.30	11.30	10.00	10.00	-	5.00	0.72	1.93	0.53	1.25	12.01	9.51	2.39	7.72	7.32	350

OVERALL							SHAFT					KEY THK.	BEARING	
BA	C	D	L	O	P	T	U	N-W	KEYWAY				DRIVE END	OPP. DRIVE END
									R	ES	S			
4.25	24.86	6.25	11.61	12.75	12.76	2.01	1.625	4.00	1.416	2.91	0.375	0.375	6309ZC3	6309ZC3

NOTE

1. Dimension "D" tolerance : +0.00inch - 0.03inch (143T-365T) ; +0.000inch - 0.06inch (404T-449T)
2. Dimension "U" tolerance : +0.000inch - 0.005inch (143T-215T), +0.000inch - 0.001inch (254T-449T)
3. Dimension "R" tolerance : +0.000inch - 0.015inch

APPD BY	S.Y.KIM	UNIT	inch	SUBJECT	NEMA 256T	DWG SIZE	A4 (1:10)	
CHKD BY	R.G.KIM	SCALE	1/10	TITLE	OUTLINE			
CHKD BY		PROJEC'N	3rd Angle					
DSND BY	J.H.JEON	DATE	2021-04-15					



REF. NO	.	Sheet No.	of
DWG NO	LM-U0256B3TL001	Revision No.	0

Cls. I Div. 1

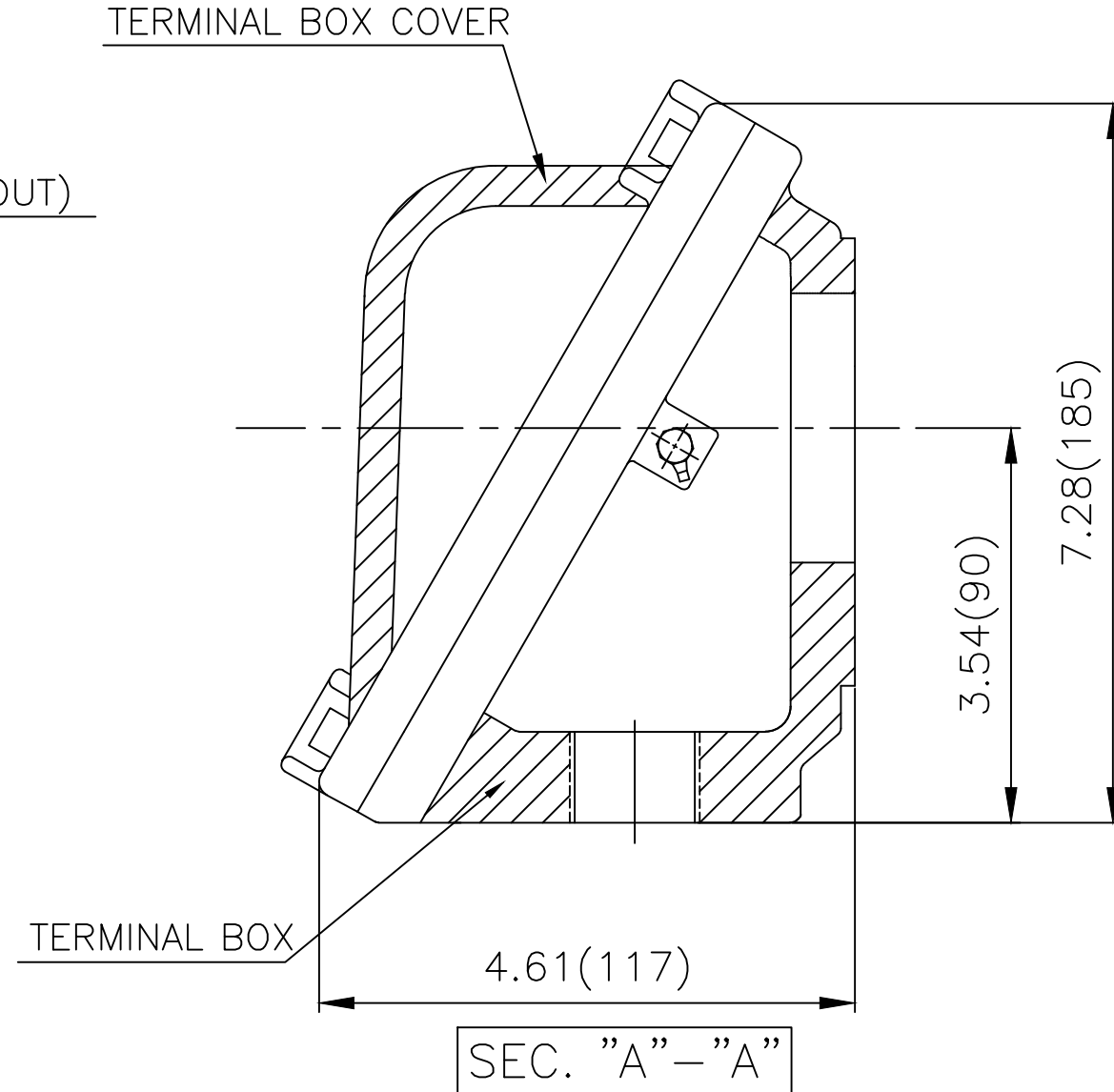
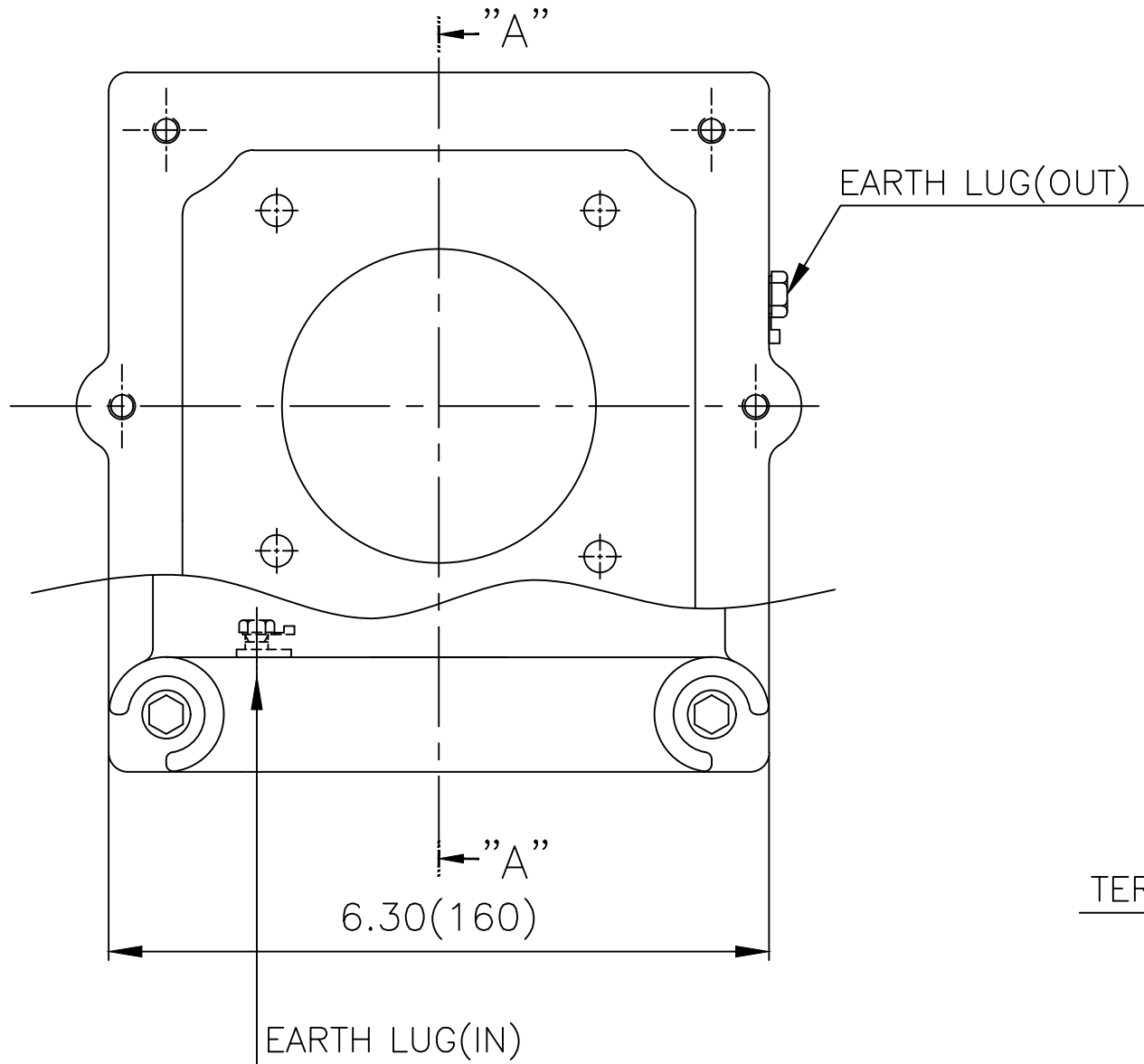

▽	50S
▽▽	12.5S
▽▽▽	3.2S
▽▽▽▽	0.4S

REV	DATE	CONTENTS	REVD BY	CHKD BY	CHKD BY	APPD BY

일반가공공차		일반제관공차	
1-4	±0.1	6-30	±0.5
4-18	±0.2	30-120	±0.8
18-63	±0.3	120-315	±1.2
63-250	±0.5	315-1000	±2.0
250-	±0.8	1000-	±3.0

Q'TY	DESCRIPTION	MATERIAL	DIMENSION	WEIGHT	PART NO.	REMARK	NO.
APPD BY	S.Y.KIM	UNIT	inch(mm)	SUBJECT	NEMA FR. 250~280(CAST IRON)		DWG SIZE
CHKD BY	R.G.KIM	SCALE	1/1.5	TITLE	MAIN TERMINAL BOX ASS'Y		A3 (1:1.5)
CHKD BY		PROJEC'N	3rd Angle	REF. NO		Sheet No.	of
DSND BY	김은진	DATE	2023-11-08	DWG NO	3M-248637	Revision No.	0

