

Customer :  
Project Name :  
Project No. :  
Revision No. :

# SPECIFICATION for INDUCTION MOTOR



0		For Bidding			
No.	DATE	DESCRIPTION	PREPARED BY	CHECKED BY	APPROVED BY



# AC INDUCTION MOTOR DATA SHEET

## Explosion Proof type

Catalog No.	IXHHI2-12-184T	Item No.	Rev. No. [      ]
Project Name		Project No.	Quantity                      sets

GENERAL SPECIFICATION		PERFORMANCE DATA			
Frame Size	184T	Rated Output	1.5 kW                      2 HP		
Type	XJP	Number of Poles	6		
Enclosure(Protection)	Totally Enclosed / IP55	Rotor Type	Squirrel Cage		
Method of Cooling	IC411(FC)	Starting Method*	D.O.L		
Rated Frequency	60 Hz	Rated Voltage	575 V	460 V	230 V
Number of Phases	3	Current	Full Load	2.50 A	3.13 A
Insulation Class	F		Locked-rotor**	790 %	790 %
Temp. Rise at full load (by resistance method)		Efficiency			
at 1.0 S.F	80 deg. C	50% Load		85.5 %	
Motor Location	<input type="checkbox"/> Indoor <input type="checkbox"/> Outdoor	75% Load		87.5 %	
Altitude	Less than 1,000 meter	100% Load		88.5 %	
Relative Humidity	Less than 80 %	Power Factor(p.u)			
Ambient Temp.	40 deg. C (Max.)	50% Load		0.530	
Duty Type	Continuous ( S1 )	75% Load		0.630	
Service Factor	1.15	100% Load		0.680	
Mounting	B3	Speed at Full Load	1175 r.p.m		
Bearing	Type	Anti-Friction	Torque		
	DE/N-DE	6206ZZC3 / 6206ZZC3	Full Load	9.0 lb.ft	
	Lubricant	Grease(Polyrex-EM)	Locked-rotor**	180 %	
External Thrust	Not applicable	Breakdown**	260 %		
Coupling Method	<input checked="" type="checkbox"/> Direct <input type="checkbox"/> V-belt	Moment of Inertia (J)			
Shaft Extension	Single	Load(Max.)	42.358 lb.ft2		
Terminal Box	Main	Cast Iron	Motor	0.712 lb.ft2	
	Aux.	No	Sound Pressure Level (No-load & mean value at 1m from motor)		
Location	Refer to Outline Drawing	60 dB(A)			
Application		Vibration			
Area classification	Hazardous	0.0 mm/sec (peak)			
Type of Ex-Protection	Class I&II, Division 1	Permissible number of consecutive starts	Cold	0 times	
Applicable Standard	NEMA MG1, CSA C390, UL674	Hot	0 times		
		Paint	Munsell No.	4.0PB5.4/5.5(VL-451)	

ACCESSORIES
*. W.T.D.(Thermostat, 145°C) : 1EA/Ph.

SPARE PARTS

SUBMITTAL DRAWING		
Outline Dimension Drawing	Motor Weight(Approx.)	
B3	LM-U0184B3TL001	121 lb.

**REMARK**

1. Premium efficiency according to NEMA MG1
2. Inverter Duty @ 1.0 Service Factor & Ambient max 45°C
  - CT 10.5Hz to 60Hz (10:1 CT at 1hour Duty)
  - 10:1 VT (20:1 VT at 50% load)
  - CHP up to 1.5 times base speed, NEMA MG1 Part31
3. Class I, Division 1, Group C&D
  - Temp.Code(Sine wave) : T2C at 40°C Amb./T2B at 55°C Amb.
  - T4 with Winding Temperature Detector
4. Class II, Division 1, Group F&G
  - Temp.Code(Sine wave) : T3B

Date	DSND	CHKD	CHKD	APPD
2024-08-08	S.H. Lee	I.K. Kim	R.G. Kim	S.W. Kim

[Note] Others not mentioned in this data sheet shall be in accordance with maker standard.  
 Above technical data are only design values and shall be guaranteed with tolerance of applicable standard.  
 Inspection and performance test shall be done according to maker standard, if not mentioned.  
 \* In case of Inverter-Fed Motor, performance data is based on sine wave tests. It may be different from test data of Inverter combined motor.  
 \*\* Data is based on rated voltage & frequency and is expressed as a percentage of full-load value.

1	2	3	4
REV	DATE	CONTENTS	REVD BY

3.94

1.57

<b>CROWN TRITON</b>		Premium Efficiency AC 3 Phase Motor		Explosion Proof		UL US LISTED	
2HP	6P	230/460V	Cat. No. IXHHI2-12-184T		Amb.	40°C	
Frame	184T	Duty	CONT	Amps	6.26/3.13	Type	XJP
RPM	1175	Hertz	60Hz	Encl.	TEFC	Model	LATER
Bearing	Drive	6206ZZC3	S.F.	1.15	on sine wave power	INS. Class	F
	Opp.	6206ZZC3	S.F.	1.00	on PWM or IGBT power	HD-F1	NEMA Design B
Usable at	50Hz 1.5HP 380V 3.9A 975rpm S.F.: 1.0 Eff.: 78.1% Code: L						
	50Hz 1.5HP 400/415V 5/4.2A 975/980rpm S.F.: 1.0 Eff.: 78.1/78.1% Code: L/L						
UL Certified for	CLASS I, Div. 1, Gr. C & D / CLASS I, Zone 1, Gr. IIA & IIB				Temp. Code	T2C at 40°C Amb. / T2B at 55°C Amb.	
	10:1VT(20:1 at 50% load) CT 10.5Hz to base Hz(10:1 1hour duty at lowest RPM) CHP upto 1.5 time base speed, NEMA MG1 part 31. Amb max 45°C for inverter duty.				(sine wave)	T4 With Thermostat	
No.	-		Date	-		Weight	121 lb
4M-136031 (NEMA 182~215Fr.)		Made in Korea H1			<b>HD HYUNDAI ELECTRIC</b>		

APPD BY	S.Y.KIM	UNIT	INCH	SUBJECT	UL Class I, Division1 (IXHHI)	DWG SIZE
CHKD BY	I.K.KIM	SCALE	NONE			A4 ( 1:1 )
CHKD BY	R.G.KIM	PROJEC'N	3rd Angle	TITLE NAMEPLATE DRAWING		
DSND BY	S.H.LEE	DATE	2024.06.07			
<b>HD HYUNDAI ELECTRIC</b>				REF. NO	4M-136031	Sheet No. of
				DWG NO	NP-IXHHI2-12-184T	Revision No. 0

Type :	XJP
Full Load Torque :	9.0 lb.ft
Load moment of Inertia (J) :	42.358 lb.ft <sup>2</sup>
Motor moment of Inertia (J) :	0.712 lb.ft <sup>2</sup>

1.5kW	2HP	6 P	60 Hz
Speed at Full Load :			1175 RPM
Rated Voltage	575V	460V	230V
Full Load Current	2.5A	3.1A	6.3A

SPEED VS TORQUE & CURRENT CURVE

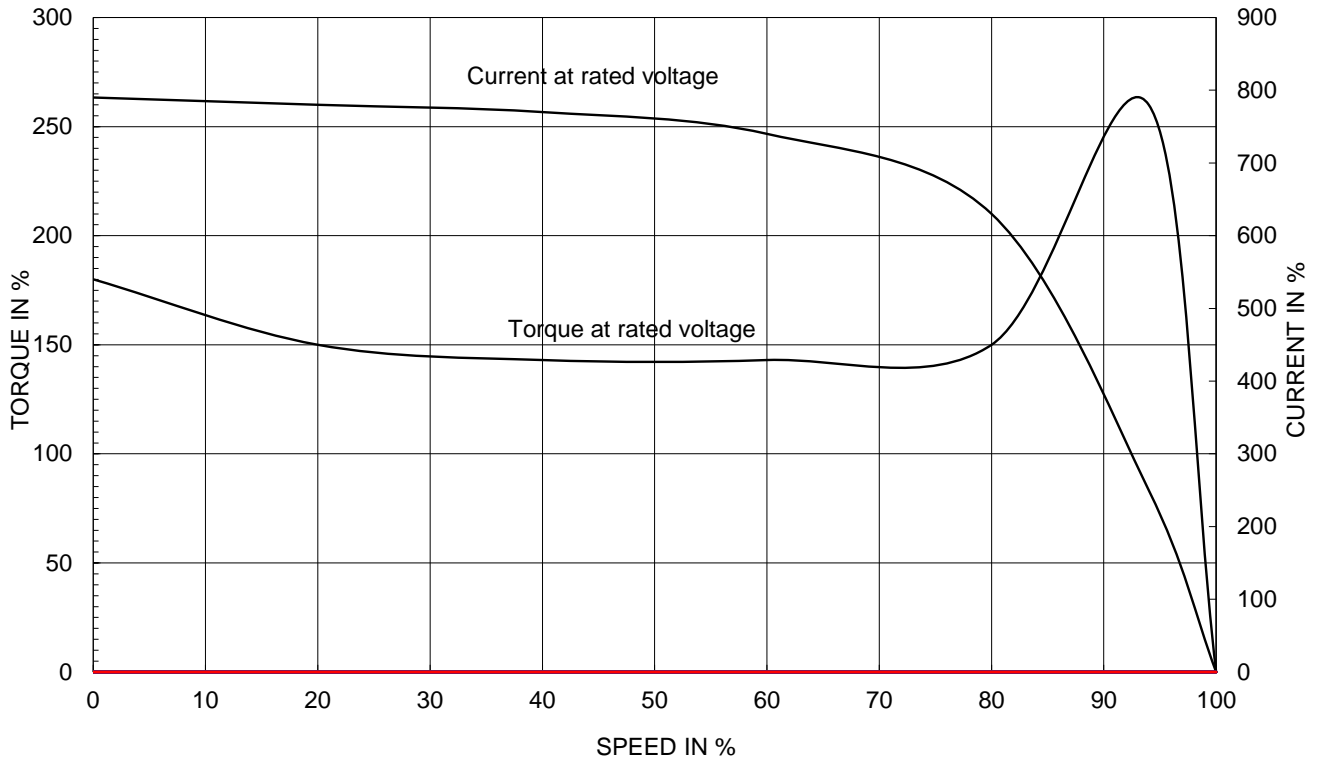

OUTPUT VS EFF., P.F & CURRENT CURVE

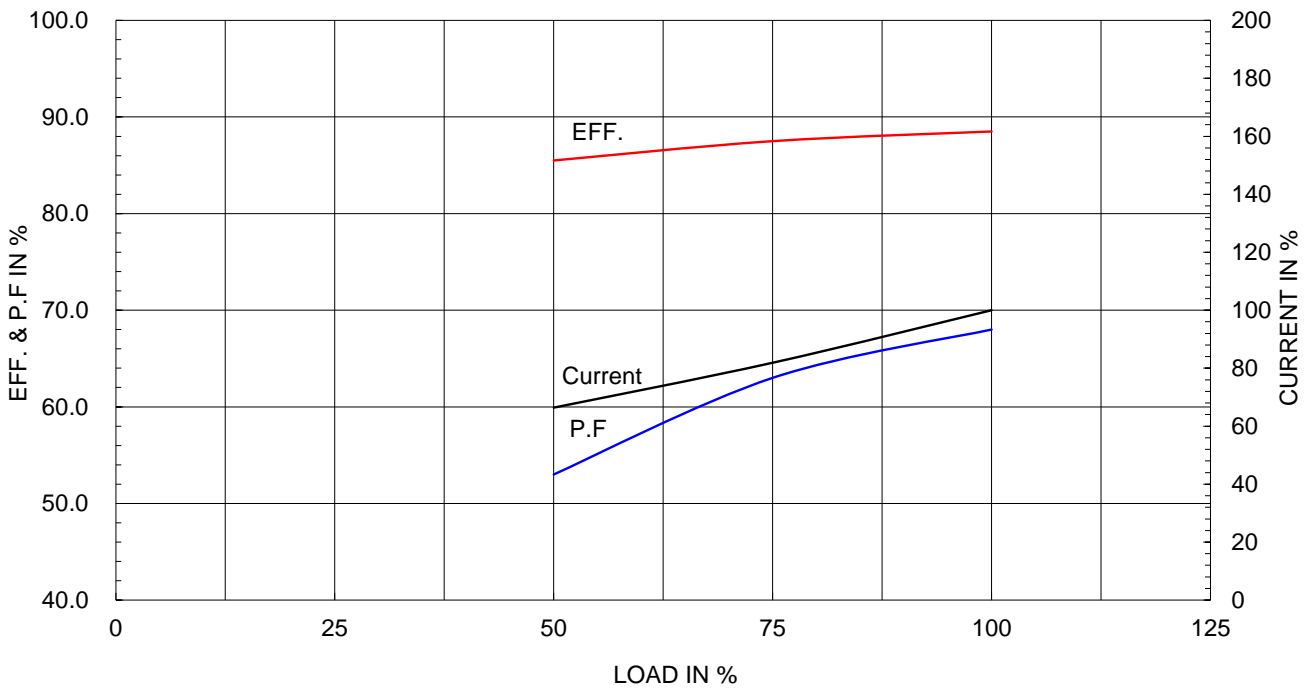

본 도면은 HD현대일렉트릭(주) 재산이며 허가없이 복사할 수 없음 (취급주의)

THIS DRAWING IS PROPRIETARY TO HYUNDAI ELECTRIC. NO PART OF THIS DRAWING MAYBE REPRODUCED WITHOUT THE PERMISSION OF HYUNDAI ELECTRIC.

1	2	3	4
▽	50S	REV	DATE
▽▽	12.5S		
▽▽▽	3.2S		
▽▽▽▽	0.4S		

### Class I Division 1

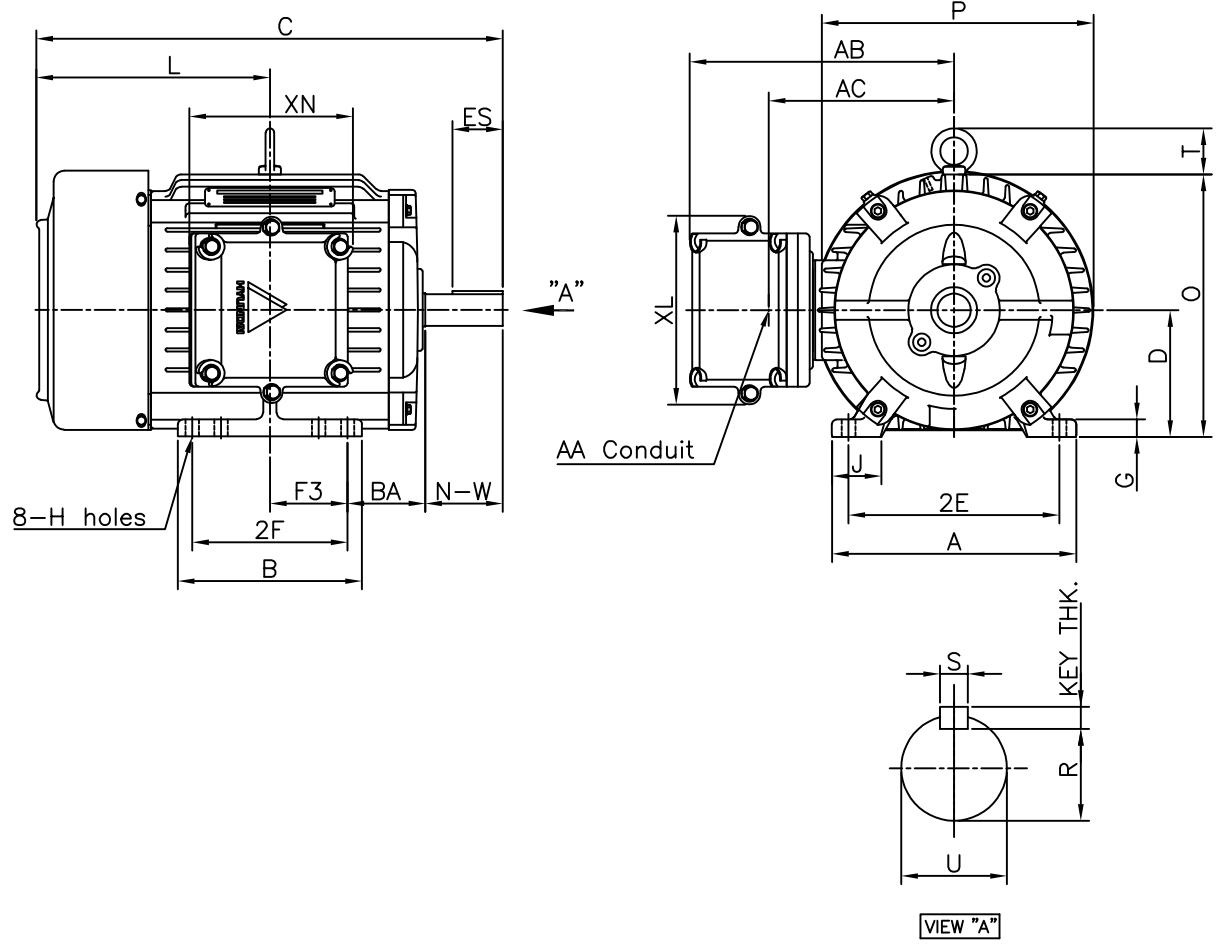

### DIMENSIONS

MOUNTING									CONDUIT BOX						APPROX. WGT.(lb)
A	B	2E	2F	-	F3	G	J	H	AA	AB	AC	XB	XL	XN	
8.66	6.54	7.50	5.50	-	2.75	0.62	1.74	0.41	0.75	9.38	6.58	-	6.69	5.98	121

OVERALL									SHAFT			KEY THK.	BEARING	
BA	C	D	L	O	P	T	U	N-W	KEYWAY				DRIVE END	OPP. DRIVE END
									R	ES	S			
2.75	16.55	4.50	8.29	9.32	9.64	1.63	1.125	2.75	0.986	1.78	0.250	0.250	6206ZZC3	6206ZZC3

### NOTE

1. Dimension "D" tolerance : +0.00inch - 0.03inch (143T-365T) ; +0.000inch - 0.06inch (404T-449T)
2. Dimension "U" tolerance : +0.000inch - 0.005inch (143T-215T), +0.000inch - 0.001inch (254T-449T)
3. Dimension "R" tolerance : +0.000inch - 0.015inch

APPD BY	S.Y.KIM	UNIT	inch	SUBJECT	NEMA 184T	DWG SIZE	A4 ( 1:7 )
CHKD BY	R.G.KIM	SCALE	1/10	TITLE	OUTLINE	Sheet No.	of
CHKD BY		PROJEC'N	3rd Angle				
DSND BY	J.H.JEON	DATE	2021-04-15				
				REF. NO	.	Sheet No.	of
				DWG NO	LM-U0184B3TL001	Revision No.	0



# Cls. I Div. 1

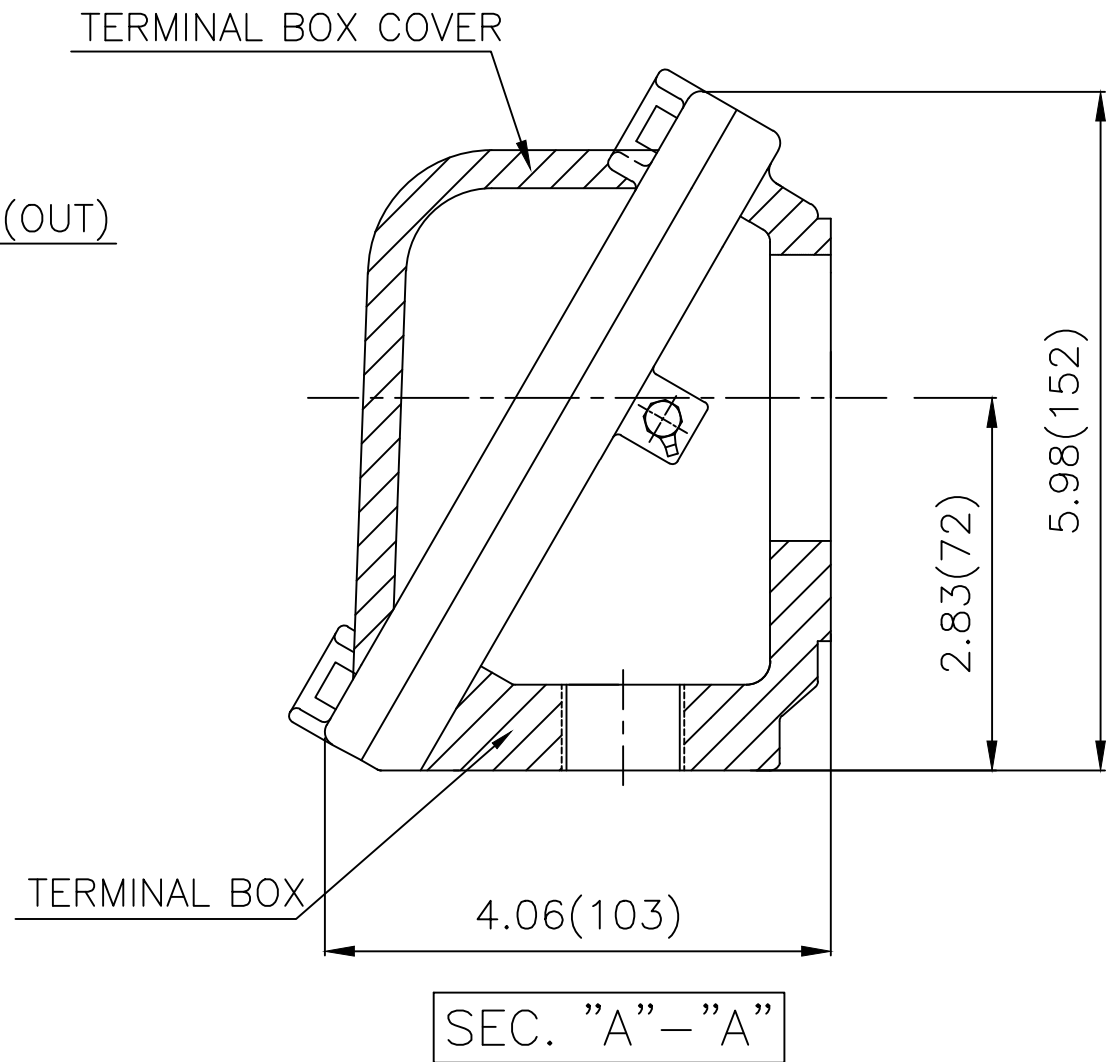
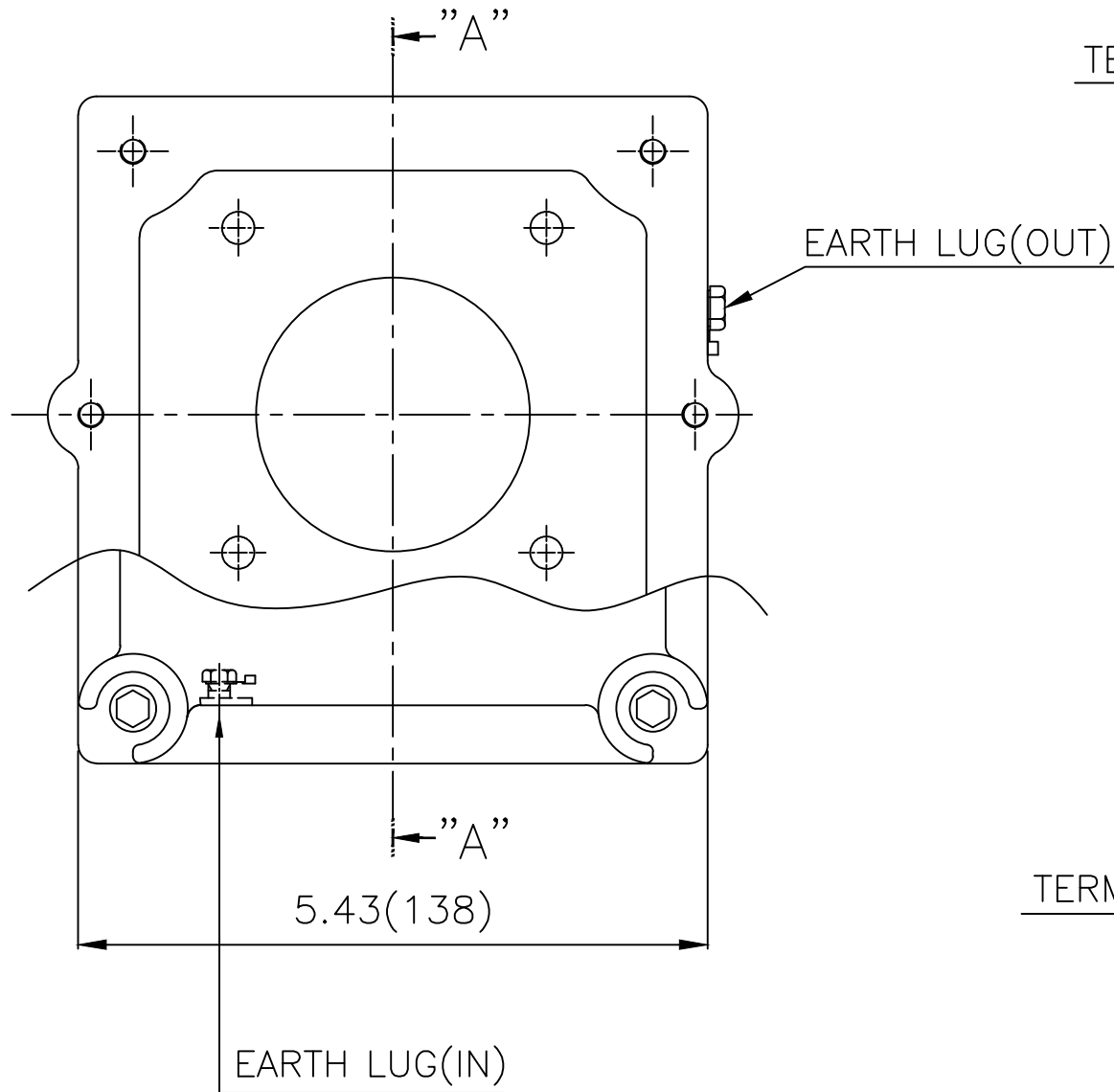

▽	50S
▽▽	12.5S
▽▽▽	3.2S
▽▽▽▽	0.4S

REV	DATE	CONTENTS	REVD BY	CHKD BY	CHKD BY	APPD BY

일반가공공차		일반제관공차	
1-4	±0.1	6-30	±0.5
4-18	±0.2	30-120	±0.8
18-63	±0.3	120-315	±1.2
63-250	±0.5	315-1000	±2.0
250-	±0.8	1000-	±3.0

Q'TY	DESCRIPTION	MATERIAL	DIMENSION	WEIGHT	PART NO.	REMARK	NO.
APPD BY	S.Y.KIM	UNIT	lφφh(mm)	SUBJECT	NEMA FR. 180~210(CAST IRON)	DWG SIZE	A3 (1:1.5)
CHKD BY	R.G.KIM	SCALE	1/1.5	TITLE	MAIN TERMINAL BOX ASS'Y		
CHKD BY		PROJEC'N	3rd Angle	REF. NO		Sheet No.	of
DSND BY	김은진	DATE	2023-10-24	DWG NO	3M-248496	Revision No.	0

