

Customer :  
Project Name :  
Project No. :  
Revision No. :

# SPECIFICATION for INDUCTION MOTOR



0		For Bidding			
No.	DATE	DESCRIPTION	PREPARED BY	CHECKED BY	APPROVED BY



# AC INDUCTION MOTOR DATA SHEET

## Explosion Proof type

Catalog No.	IXHHI7.5-12-254TC	Item No.		Rev. No.	[      ]
Project Name		Project No.		Quantity	sets

GENERAL SPECIFICATION			PERFORMANCE DATA			
Frame Size	254TC		Rated Output	5.5 kW		7.5 HP
Type	XJP		Number of Poles	6		
Enclosure(Protection)	Totally Enclosed	/ IP55	Rotor Type	Squirrel Cage		
Method of Cooling	IC411(FC)		Starting Method*	D.O.L		
Rated Frequency	60 Hz		Rated Voltage	575 V	460 V	230 V
Number of Phases	3		Current	Full Load	8.09 A	10.11 A
Insulation Class	F			Locked-rotor**	640 %	640 %
Temp. Rise at full load (by resistance method)			Efficiency			
at 1.0 S.F	80 deg. C		50% Load		88.0 %	
Motor Location	<input type="checkbox"/> Indoor <input type="checkbox"/> Outdoor		75% Load		90.0 %	
Altitude	Less than 1,000 meter		100% Load		91.0 %	
Relative Humidity	Less than 80 %		Power Factor(p.u)			
Ambient Temp.	40 deg. C (Max.)		50% Load		0.600	
Duty Type	Continuous ( S1 )		75% Load		0.700	
Service Factor	1.15		100% Load		0.750	
Mounting	B35		Speed at Full Load	1175 r.p.m		
Bearing	Type	Anti-Friction	Torque			
	DE/N-DE	6309ZC3 / 6309ZC3	Full Load		33.0 lb.ft	
	Lubricant	Grease(Polyrex-EM)	Locked-rotor**		170 %	
External Thrust	Not applicable		Breakdown**		250 %	
Coupling Method	<input checked="" type="checkbox"/> Direct <input type="checkbox"/> V-belt		Moment of Inertia (J)			
Shaft Extension	Single		Load(Max.)		126.887 lb.ft2	
Terminal Box	Main	Cast Iron	Motor		2.136 lb.ft2	
	Aux.	No	Sound Pressure Level (No-load & mean value at 1m from motor)			
	Location	Refer to Outline Drawing			64 dB(A)	
Application			Vibration		0.0 mm/sec (peak)	
Area classification	Hazardous		Permissible number of consecutive starts		Cold 0 times Hot 0 times	
Type of Ex-Protection	Class I&II, Division 1		Paint	Munsell No.	4.0PB5.4/5.5(VL-451)	
Applicable Standard	NEMA MG1, CSA C390, UL674					

### ACCESSORIES

\*. W.T.D.(Thermostat, 145°C) : 1EA/Ph.

### SPARE PARTS

### SUBMITTAL DRAWING

Outline Dimension Drawing		Motor Weight(Approx.)	
B35	LM-U0254C4TL001	260 lb.	

### REMARK

- Premium efficiency according to NEMA MG1
- Inverter Duty @ 1.0 Service Factor & Ambient max 45°C
  - 4:1 CT (10:1 CT at 1hour Duty)
  - 10:1 VT (20:1 VT at 50% load)
  - CHP up to 1.5 times base speed, NEMA MG1 Part31
- Class I, Division 1, Group C&D
  - Temp.Code(Sine wave) : T2D at 40°C Amb./T2C at 55°C Amb.  
T4 with Winding Temperature Detector
- Class II, Division 1, Group F&G
  - Temp.Code(Sine wave) : T3B

Date	DSND	CHKD	CHKD	APPD
2024-08-08	S.H. Lee	I.K. Kim	R.G. Kim	S.W. Kim

[Note] Others not mentioned in this data sheet shall be in accordance with maker standard.  
 Above technical data are only design values and shall be guaranteed with tolerance of applicable standard.  
 Inspection and performance test shall be done according to maker standard, if not mentioned.  
 \* In case of Inverter-Fed Motor, performance data is based on sine wave tests. It may be different from test data of Inverter combined motor.  
 \*\* Data is based on rated voltage & frequency and is expressed as a percentage of full-load value.

1	2	3	4
REV	DATE	CONTENTS	REVD BY   CHKD BY   CHKD BY   APPD BY

4.72

**CROWN TRITON**  
Premium Efficiency AC 3 Phase Motor

**Explosion Proof**









7.5HP	6P	230/460V	Cat. No.	IXHHI7.5-12-254TC	Amps	20.23/10.	
Model	LATER		INS. Class	F HD-F1	Hertz	60Hz	
Type	XJP	Duty	CONT	Code	H	NEMA Nom. Eff.	91%
Frame	254TC	Encl.	TEFC	S.F.	1.15	on sine wave power	3/4 Eff. 90%
Bearing	Drive	6309ZC3	S.F.	1.00	on PWM or IGBT power	NEMA Design	B
	Opp.	6309ZC3	RPM	1175		Amb.	40°C
Usable at	50Hz 5HP 380V 10.3A 980rpm S.F.: 1.0 Eff.: 84.6% Code: L						
	50Hz 5HP 400/415V 10.5/10.7A 985/985rpm S.F.: 1.0 Eff.: 84.6/84.6% Code: L/L						
UL Certified for	Class I, Div. 1, Group C&D / Class I, Zone 1, Group II A & II B				Temp. Code	T2D at 40°C Amb. / T2C at 55°C Amb.	
	10:1VT(20:1 at 50% load) 4:1CT(10:1 1hour duty at lowest RPM) CHP upto 1.5 time base speed, NEMA MGI part 31. Amb max 45°C for inverter duty.					(sine wave)	T4 With Thermostat
No.	-		Date	-		Weight	260 lb

4M-136066  
(NEMA 250~280Fr.)

Made in Korea H1



2.36

APPD BY	S.Y.KIM	UNIT	INCH	SUBJECT	UL Class I, Division1 (IXHHI)	DWG SIZE
CHKD BY	I.K.KIM	SCALE	NONE			A4 ( 1:1 )
CHKD BY	R.G.KIM	PROJEC'N	3rd Angle	TITLE <b>NAMEPLATE DRAWING</b>		
DSND BY	S.H.LEE	DATE	2024.06.07			
				REF. NO	4M-136066	Sheet No. of
				DWG NO	NP-IXHHI7.5-12-254TC	Revision No. 0



# PERFORMANCE CURVE

CURVE NO.  
PC-IXHHI7.5-12-254TC

Type :	XJP
Full Load Torque :	33.0 lb.ft
Load moment of Inertia (J) :	126.887 lb.ft2
Motor moment of Inertia (J) :	2.136 lb.ft2

5.5kW	7.5HP	6 P	60 Hz
Speed at Full Load :			1175 RPM
Rated Voltage	575V	460V	230V
Full Load Current	8.1A	10.1A	20.2A

SPEED VS TORQUE & CURRENT CURVE

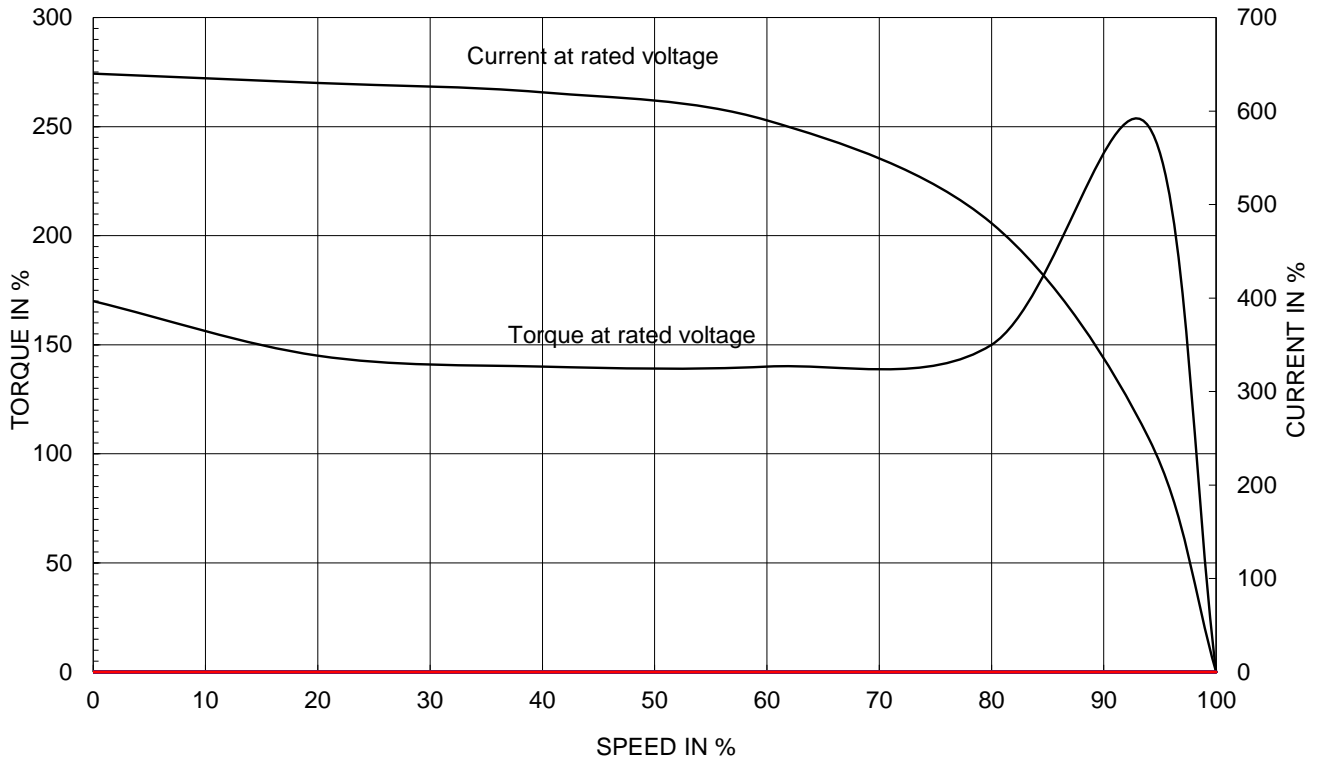

OUTPUT VS EFF., P.F & CURRENT CURVE

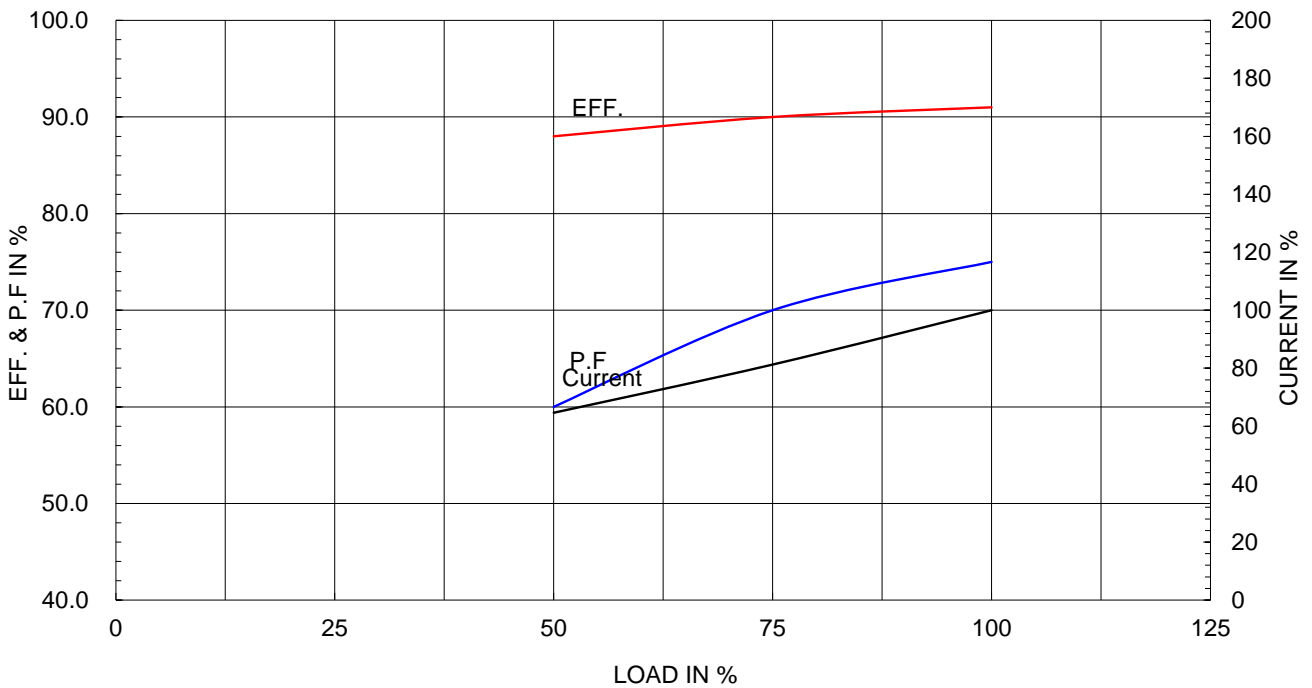

본 도면은 HD현대일렉트릭(주) 재산이며 허가없이 복사할 수 없음 (최급유위)

THIS DRAWING IS PROPRIETARY TO HYUNDAI ELECTRIC. NO PART OF THIS DRAWING MAY BE REPRODUCED WITHOUT THE PERMISSION OF HYUNDAI ELECTRIC.

1	2	3	4
▽	50S	REV	DATE
▽▽	12.5S		
▽▽▽	3.2S		
▽▽▽▽	0.4S		

**Class I Division 1**

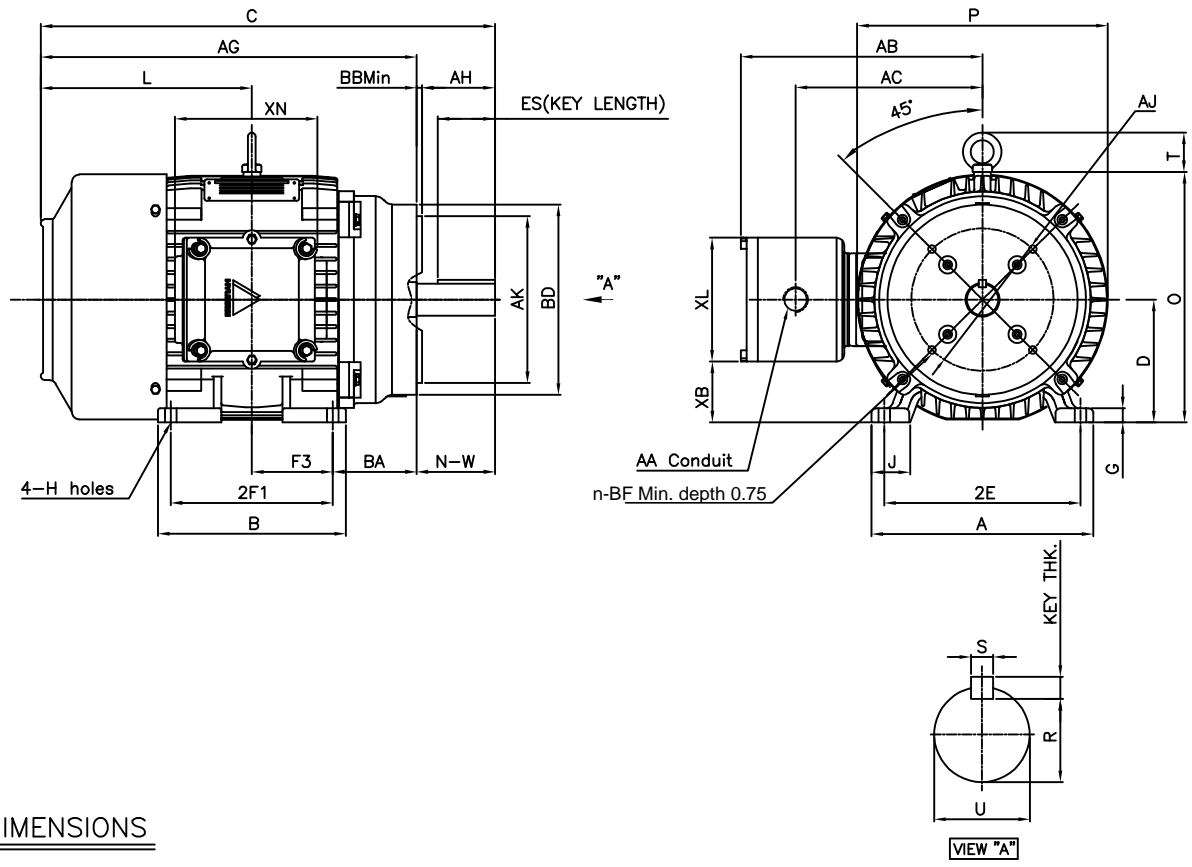

DIMENSIONS

MOUNTING									CONDUIT BOX					APPROX. WGT.(LB)	
A	B	2E	2F1	2F2	F3	G	J	H	AA	AB	AC	XB	XL	XN	
11.30	9.56	10.00	8.25	-	4.13	0.72	1.93	0.53	1.25	12.01	9.51	3.15	6.30	7.32	260

OVERALL								SHAFT					KEY THK.	BEARING	
AG	BA	C	D	L	O	P	T	U	N-W	KEYWAY		0.375	DRIVE END	OPP. DRIVE END	
										R	ES				S
19.13	4.25	23.13	6.25	10.75	12.75	12.76	2.01	1.625	4.00	1.416	2.91	0.375	0.375	6309ZC3	6309ZC3

C-FACE						
AJ	AK	BD	BB	BF	n	AH
7.25	8.50	9.68	0.25	1/2-13	4	3.75

NOTE

- 1.Dimension "D" tolerance : +0.00inch ~ -0.03inch (143TC-365TC) : +0.000inch ~ -0.06inch (404TC-449TC)
- 2.Dimension "U" tolerance : +0.000inch ~ -0.0005inch (143TC-215TC): +0.000inch ~ -0.001inch (254TC-449TC)
- 3.Dimension "R" tolerance : +0.000inch ~ - 0.015inch
- 4.Dimension "AK" tolerance : +0.000inch ~ -0.003inch (143TC-286TC): +0.000inch ~ -0.005inch (324TC-449TC)

APPD BY	S.Y.KIM	UNIT	inch	SUBJECT	NEMA 254TC(KIT)	DWG SIZE	A4 ( 1:10 )
CHKD BY	R.G.KIM	SCALE	1/10	TITLE	OUTLINE	REF. NO	Sheet No. of
CHKD BY		PROJEC'N	3rd Angle				
DSND BY	J.H.JEON	DATE	2021-04-15				



DWG NO	LM-U0254C4TL001	Revision No.	0
--------	-----------------	--------------	---

# Cls. I Div. 1

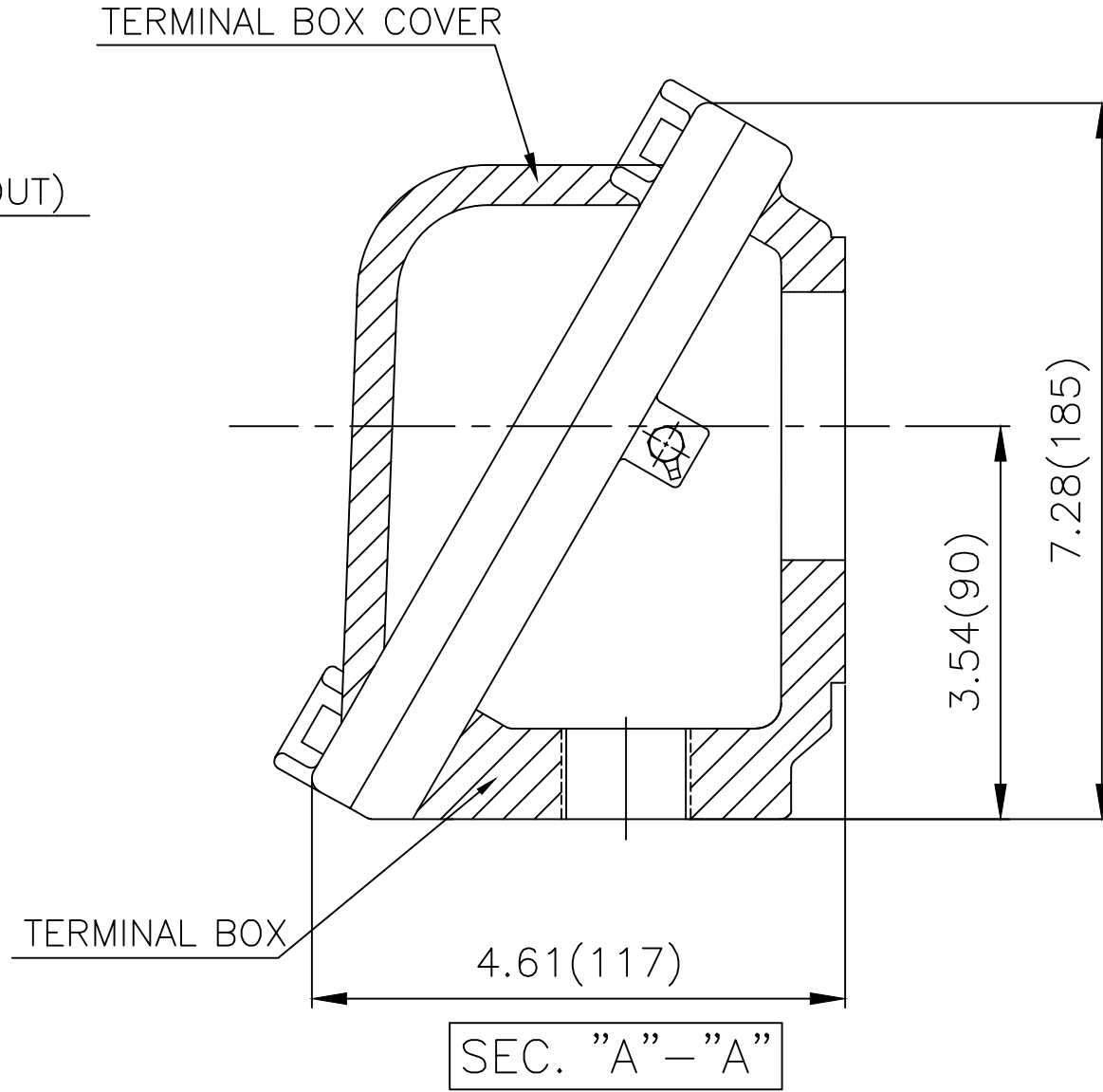
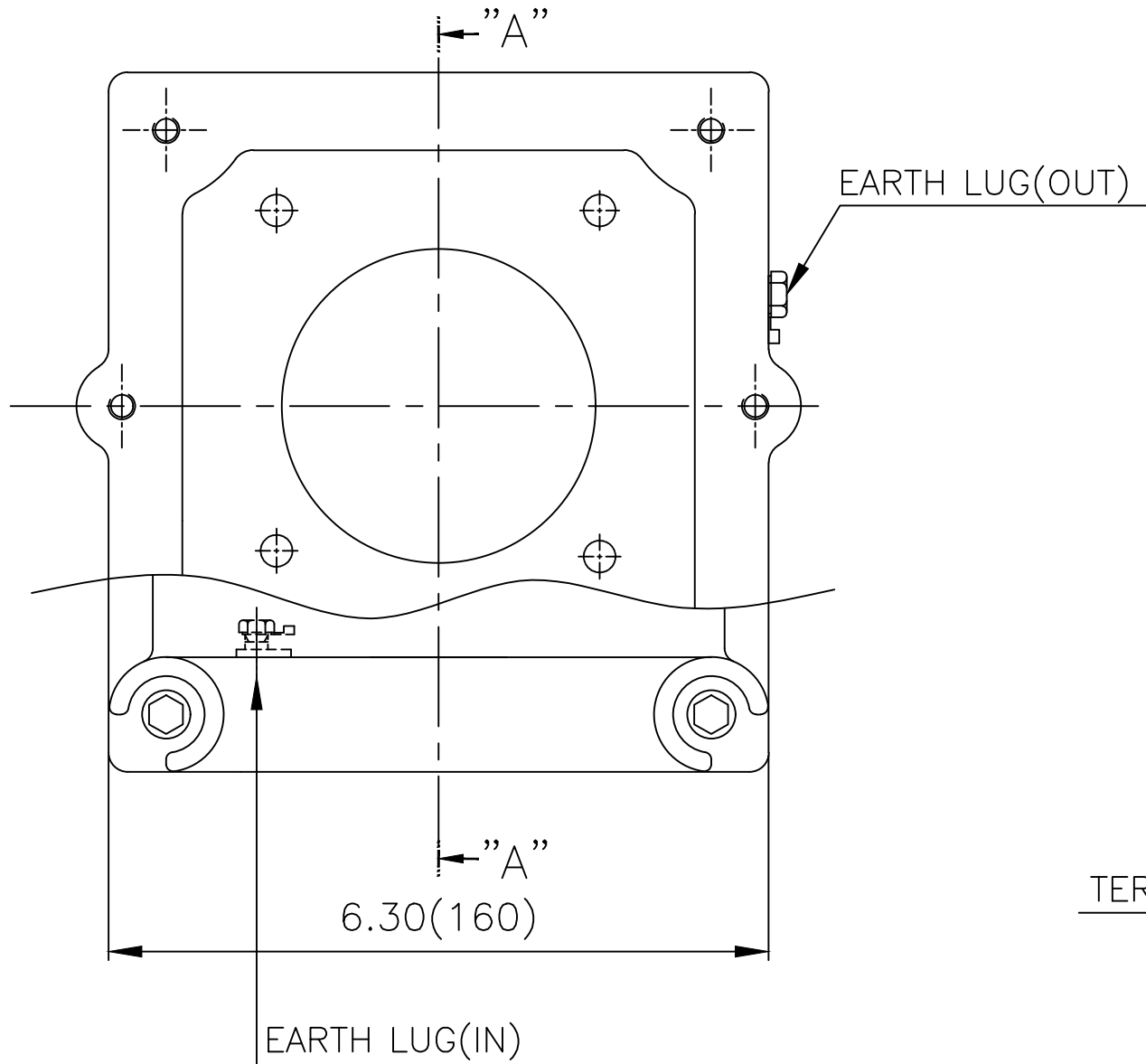

▽	50S
▽▽	12.5S
▽▽▽	3.2S
▽▽▽▽	0.4S

REV	DATE	CONTENTS	REVD BY	CHKD BY	CHKD BY	APPD BY

일반가공공차		일반제관공차	
1-4	±0.1	6-30	±0.5
4-18	±0.2	30-120	±0.8
18-63	±0.3	120-315	±1.2
63-250	±0.5	315-1000	±2.0
250-	±0.8	1000-	±3.0

Q'TY	DESCRIPTION	MATERIAL	DIMENSION	WEIGHT	PART NO.	REMARK	NO.
APPD BY	S.Y.KIM	UNIT	inch(mm)	SUBJECT	NEMA FR. 250~280(CAST IRON)	DWG SIZE	A3 (1:1.5)
CHKD BY	R.G.KIM	SCALE	1/1.5	TITLE	MAIN TERMINAL BOX ASS'Y		
CHKD BY		PROJEC'N	3rd Angle	REF. NO		Sheet No.	of
DSND BY	김은진	DATE	2023-11-08	DWG NO	3M-248637	Revision No.	0

