

Customer :
Project Name :
Project No. :
Revision No. :

SPECIFICATION for INDUCTION MOTOR



0		For Bidding			
No.	DATE	DESCRIPTION	PREPARED BY	CHECKED BY	APPROVED BY



AC INDUCTION MOTOR DATA SHEET

Catalog No.	HES25-12-324TC	Item No.		Rev. No.	[]
Project Name		Project No.		Quantity	sets

GENERAL SPECIFICATION			PERFORMANCE DATA			
Frame Size	324TC		Rated Output	18.5 kW 25 HP		
Type	PJP		Number of Poles	6		
Enclosure(Protection)	Totally Enclosed	/ IP55	Rotor Type	Squirrel Cage		
Method of Cooling	IC411(FC)		Starting Method*	D.O.L		
Rated Frequency	60 Hz		Rated Voltage	575 V	460 V	230 V
Number of Phases	3		Current	Full Load	25.0 A	31.2 A 62.4 A
Insulation Class	F			Locked-rotor**	720 %	720 % 720 %
Temp. Rise at full load (by resistance method)			Efficiency			
at 1.0 S.F	80 deg. C		50% Load 90.0 %			
Motor Location	<input type="checkbox"/> Indoor <input type="checkbox"/> Outdoor		75% Load 92.0 %			
Altitude	Less than 1,000 meter		100% Load 93.0 %			
Relative Humidity	Less than 80 %		Power Factor(p.u)			
Ambient Temp.	40 deg. C (Max.)		50% Load 0.650			
Duty Type	Continuous (S1)		75% Load 0.750			
Service Factor	1.15		100% Load 0.800			
Mounting	B35		Speed at Full Load	1175 r.p.m		
Bearing	Type	Anti-Friction	Torque			
	DE/N-DE	6313ZC3 / 6212ZC3	Full Load 110.9 lb.ft			
	Lubricant	Grease(Polyrex-EM)	Locked-rotor** 170 %			
External Thrust	Not applicable		Breakdown** 210 %			
Coupling Method	<input checked="" type="checkbox"/> Direct <input type="checkbox"/> V-belt		Moment of Inertia (J)			
Shaft Extension	Single		Load(Max.) 389.183 lb.ft2			
Terminal Box	Main	Cast Iron	Motor 8.094 lb.ft2			
	Aux.	No	Sound Pressure Level (No-load & mean value at 1m from motor)			
Location	Refer to Outline Drawing		68 dB(A)			
Application			Vibration 3.8 mm/sec (peak)			
Area classification	Hazardous		Permissible number of consecutive starts			
Type of Ex-Protection	Class I&II, Division 2		Cold 3 times			
Applicable Standard	NEMA MG1, CSA C390		Hot 2 times			
			Paint	Munsell No.	4.0PB5.4/5.5(VL-451)	

ACCESSORIES

SPARE PARTS

SUBMITTAL DRAWING

Outline Dimension Drawing		Motor Weight(Approx.)	
B35	LM-T2324C4PLV23	570 lb.	

REMARK

1. Premium efficiency according to NEMA MG1
2. Inverter Duty @ 1.0 Service Factor & F Temperature rise
 - 10:1 VT (20:1 VT at 50% load)
 - 10:1 CT
 - CHP up to 1.5 times base speed, NEMA MG1 Part31
3. CSA Certification
 - Class I, Division 2, Group A, B, C & D
 - Class II, Division 2 Group E, F & G (Group E : up to 320Fr.)
4. Service Factor 1.15 and Temperature rise B are applicable under the condition of sine wave power.
5. Service Factor 1.25 is applicable to motors of 100HP or less with temperature rise F & Non-Hazardous.

Date	DSND	CHKD	CHKD	APPD
2024-07-13	S.H. Lee	I.K. Kim	R.G. Kim	S.W. Kim

[Note] Others not mentioned in this data sheet shall be in accordance with maker standard.
 Above technical data are only design values and shall be guaranteed with tolerance of applicable standard.
 Inspection and performance test shall be done according to maker standard, if not mentioned.
 * In case of Inverter-Fed Motor, performance data is based on sine wave tests. It may be different from test data of Inverter combined motor.
 ** Data is based on rated voltage & frequency and is expressed as a percentage of full-load value.

1	2	3	4
REV	DATE	CONTENTS	REVD BY

4.72

CROWN TRITON G2

Premium Efficiency AC 3 Phase Motor

25HP	6P	230/460V	Cat. No.	HES25-12-324TC			
Model	HLS324PR33		INS. Class	F	HD-F1	Amps	62.4/31.2
Type	HLS	Duty	CONT	Code	J	Amb.	40°C
Frame	324TC	Encl.	TEFC	S.F.	1.15	RPM	1175
Bearing	Drive	6313ZC3		S.F.1.25 (When 100HP or less, Temp Rise F & Non-Hazardous)		3/4 Eff.	92%
	Opp.	6212ZC3		S.F.1.00 (10:1 C.T., 20:1 V.T., NEMA-MG1 Part31)		NEMA Design	B Torque
Usable at	50Hz 20HP 380V 34.7A 980rpm S.F.: 1.0 Eff.: 89.7% Code: J						
	50Hz 20HP 400/415V 33.8/33.4A 980/985rpm S.F.: 1.0 Eff.: 89.7/89.7% Code: K/L						
CSA Certified for	Model	LATER		Type	PJP	Temp. Code	
	CLASS I, Div. 2, Gr. A, B, C & D		CLASS II, Div. 2 Gr. E, F & G		(sine wave)	Amb. 40°C	T3C (160°C)
	CLASS I, Zone 2, Gr. IIA, IIB, & IIC		(Gr. E: Up to 320FR)			Amb. 55°C	T3A (180°C)
No.	-	Date	-	Weight	570 lb		

4M-136024
MARINE DUTY IEEE45
Made in Vietnam H4
Designed By HYUNDAI, Korea

2.36

APPD BY	S.Y.KIM	UNIT	INCH	SUBJECT	CSA Class I, Division2 Severe Duty (HES, 254-326)	DWG SIZE
CHKD BY	I.K.KIM	SCALE	NONE			A4 (1:1)
CHKD BY	R.G.KIM	PROJEC'N	3rd Angle	NAMEPLATE DRAWING		
DSND BY	S.H.LEE	DATE	2024.06.07			
				REF. NO	4M-136024	Sheet No. of
				DWG NO	NP-HES25-12-324TC	Revision No. 0

Type :	PJP	
Full Load Torque :	110.9	lb.ft
Load moment of Inertia (J) :	389.183	lb.ft ²
Motor moment of Inertia (J) :	8.094	lb.ft ²

18.5kW	25HP	6 P	60 Hz
Speed at Full Load :			1175 RPM
Rated Voltage	575V	460V	230V
Full Load Current	25.0A	31.2A	62.4A

SPEED VS TORQUE & CURRENT CURVE

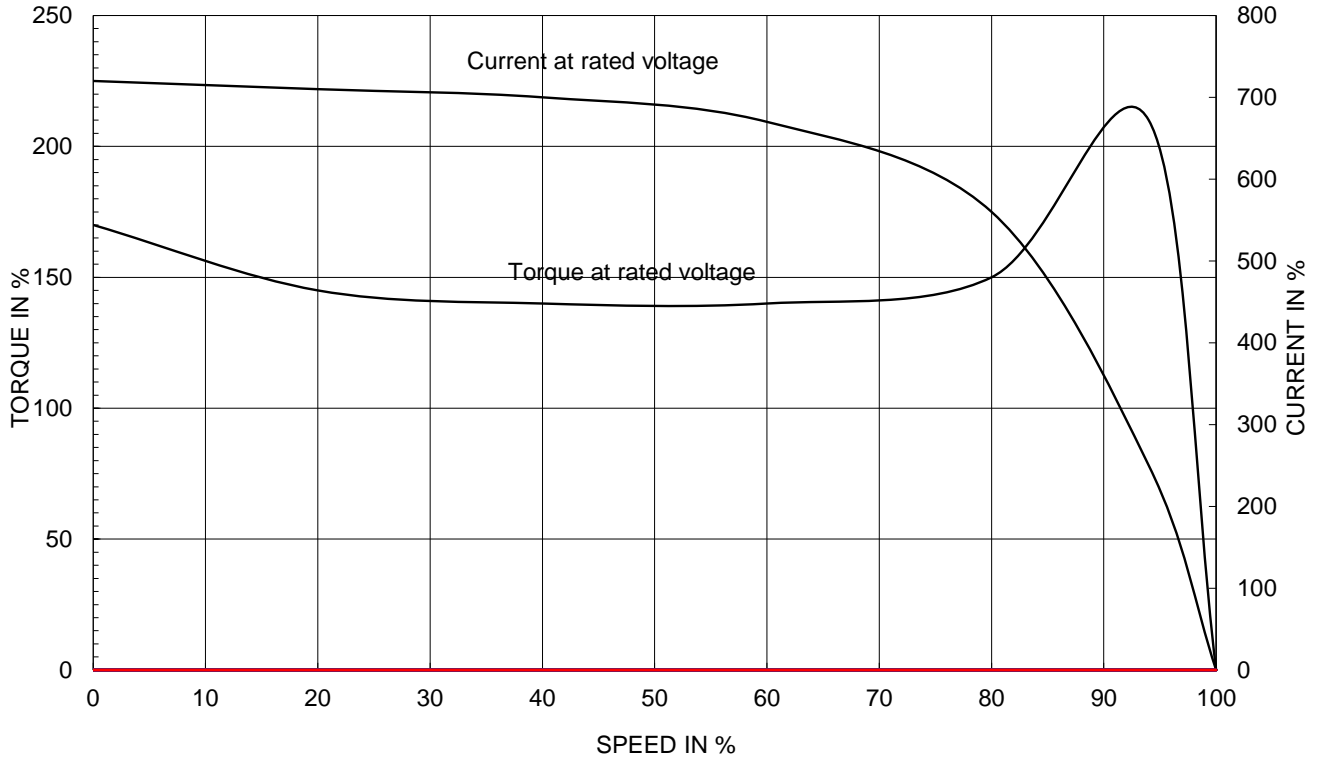

OUTPUT VS EFF., P.F & CURRENT CURVE

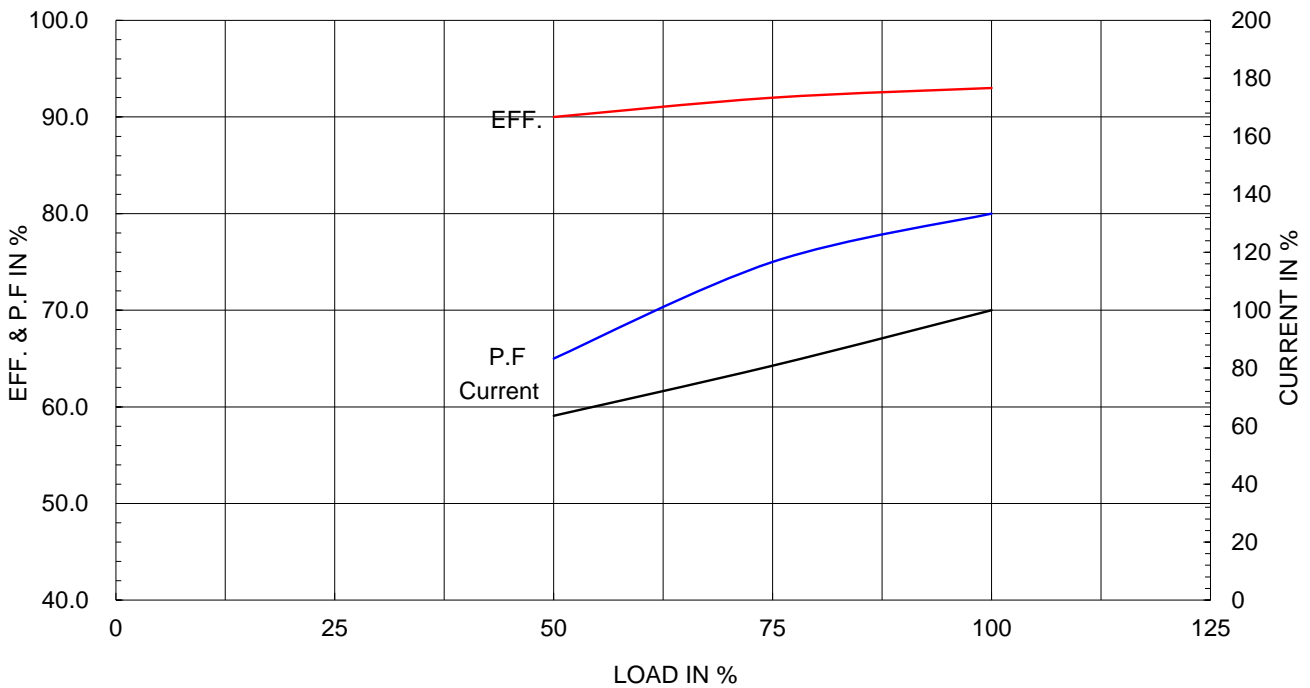

1		2		3		4			
▽	50S	REV	DATE	CONTENTS		REVD BY	CHKD BY	CHKD BY	APPD BY
▽▽	12.5S								
▽▽▽	3.2S								
▽▽▽▽	0.4S								

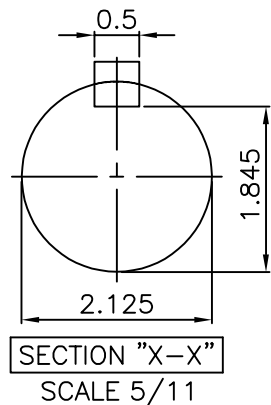
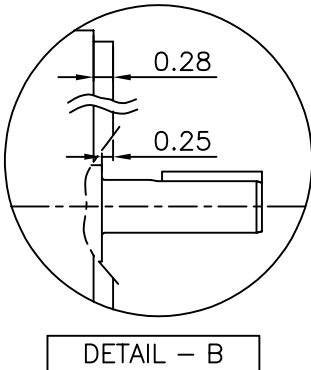
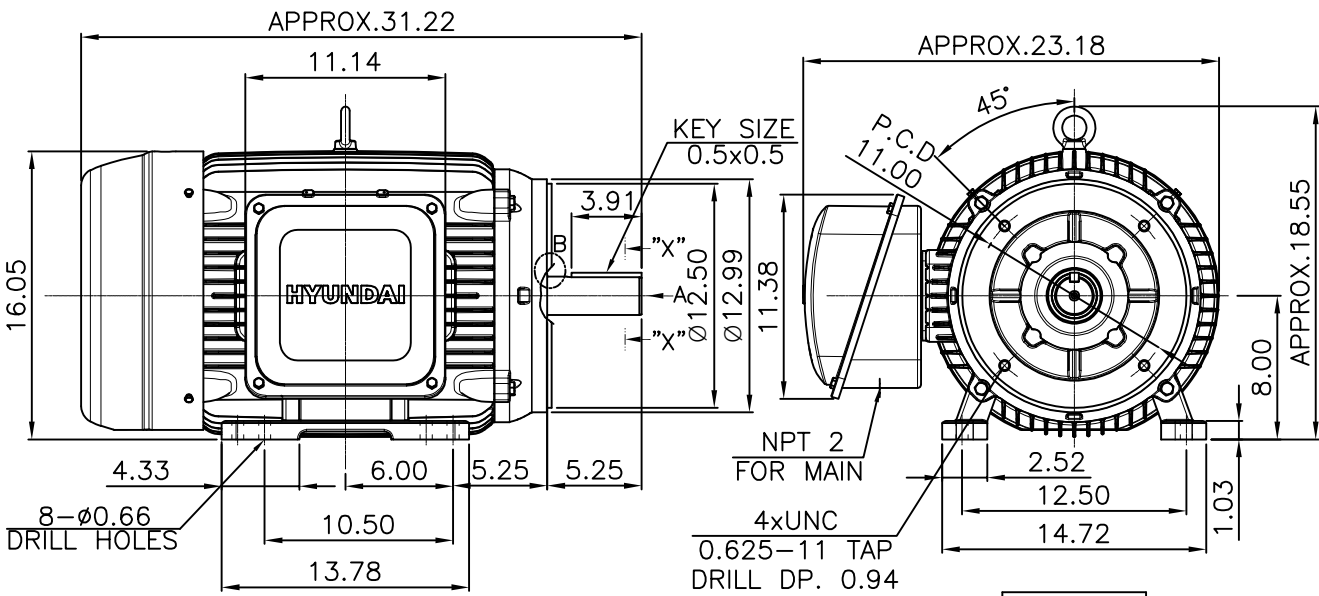

NOTE

[TOLERANCE]

1. CENTER HEIGHT : +0.00inch - 0.03inch
2. SHAFT DIAMETER : +0.000inch - 0.001inch
3. KEYWAY DEPTH : +0.000inch - 0.015inch

APPD BY	S.Y.KIM	UNIT	mm	SUBJECT	NEMA 324TC	DWG SIZE	
CHKD BY	R.G.KIM	SCALE	1/11	TITLE	OUTLINE	A4 (1:11)	
CHKD BY		PROJEC'N	3rd Angle				
DSND BY	주유림	DATE	2021-04-29				
				REF. NO		Sheet No.	of
				DWG NO	LM-T2324C4PLV23	Revision No.	0



**Cls. I&II, Div. 2
IEEE 841**

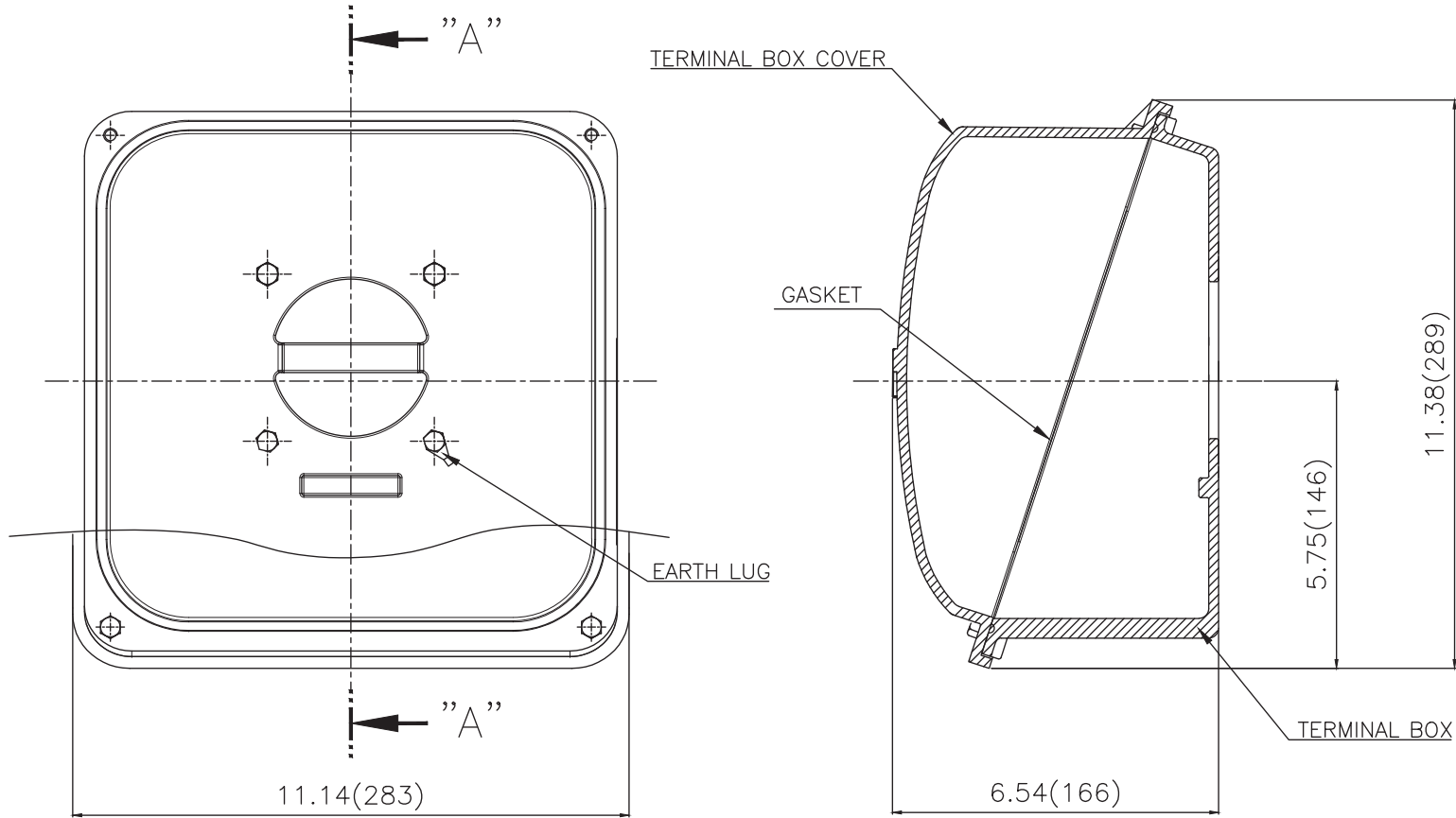

SEC. "A"-"A"

▽	50S
▽▽	12.5S
▽▽▽	3.2S
▽▽▽▽	0.4S

REV	DATE	CONTENTS	REVD BY	CHKD BY	CHKD BY	APPD BY

일반가공공차		일반재공공차	
1-4	±0.1	6-30	±0.5
4-18	±0.2	30-120	±0.8
18-63	±0.3	120-315	±1.2
63-250	±0.5	315-1000	±2.0
250-	±0.8	1000-	±3.0

Q'TY	DESCRIPTION	MATERIAL	DIMENSION	WEIGHT	PART NO.	REMARK	NO.
APPD BY	S.Y.KIM	UNIT	inch(mm)	SUBJECT	FR. 320 (CAST IRON)	DWG SIZE	
CHKD BY		SCALE	1/2.5	TITLE	TERMINAL BOX ASS'Y		
CHKD BY	R.G.KIM	PROJEC'N	3rd Angle	DATE	2023-10-19		
DSND BY	배승희						
REF. NO		Sheet No.	of				
DWG NO	3M-248459	Revision No.	0				

