

Customer :  
Project Name :  
Project No. :  
Revision No. :

# SPECIFICATION for INDUCTION MOTOR



0		For Bidding			
No.	DATE	DESCRIPTION	PREPARED BY	CHECKED BY	APPROVED BY



1	2	3	4
REV	DATE	CONTENTS	REVD BY

4.72

**CROWN TRITON G2**  
Premium Efficiency AC 3 Phase Motor







10HP	6P	230/460V	Cat. No.	HES10-12-256TC			
Model	HLS256PR33		INS. Class	F	HD-F1	Amps	27.58/13.
Type	HLS	Duty	CONT	Code	J	Amb.	40°C
Frame	256TC	Encl.	TEFC	S.F.	1.15	RPM	1175
Bearing	Drive	6309ZC3		S.F.1.25 (When 100HP or less, Temp Rise F & Non-Hazardous)		3/4 Eff.	90%
	Opp.	6309ZC3		S.F.1.00 (10:1 C.T., 20:1 V.T., NEMA-MG1 Part31)		NEMA Design	B Torque
Usable at	50Hz 7.5HP 380V 14.8A 980rpm S.F.: 1.0 Eff.: 86% Code: K						
	50Hz 7.5HP 400/415V 15.1/15.6A 980/980rpm S.F.: 1.0 Eff.: 86/86% Code: L/L						
CSA Certified for	Model	LATER		Type	PJP	Temp. Code	
	CLASS I, Div. 2, Gr. A, B, C & D	CLASS II, Div. 2 Gr. E, F & G		Frame		Amb. 40°C	T3C (160°C)
	CLASS I, Zone 2, Gr. IIA, IIB, & IIC	(Gr. E: Up to 320FR)		Amb. 55°C		T3A (180°C)	T3A (180°C)
No.	-		Date	-		Weight	310 lb

4M-136024  
**MARINE DUTY IEEE45**

Made in Vietnam H4  
Designed By HYUNDAI, Korea



2.36

APPD BY	S.Y.KIM	UNIT	INCH	SUBJECT	CSA Class I, Division2 Severe Duty (HES, 254-326)	DWG SIZE
CHKD BY	I.K.KIM	SCALE	NONE			A4 ( 1:1 )
CHKD BY	R.G.KIM	PROJEC'N	3rd Angle	TITLE <b>NAMEPLATE DRAWING</b>		
DSND BY	S.H.LEE	DATE	2024.06.07			
				REF. NO	<b>4M-136024</b>	Sheet No. of
				DWG NO	<b>NP-HES10-12-256TC</b>	Revision No. <b>0</b>



# PERFORMANCE CURVE

CURVE NO.  
PC-HES10-12-256TC

Type :	PJP
Full Load Torque :	45.0 lb.ft
Load moment of Inertia (J) :	173.035 lb.ft2
Motor moment of Inertia (J) :	3.086 lb.ft2

7.5kW 10HP	6 P	60 Hz
Speed at Full Load :		1175 RPM
Rated Voltage	575V	460V 230V
Full Load Current	11.0A	13.8A 27.6A

SPEED VS TORQUE & CURRENT CURVE

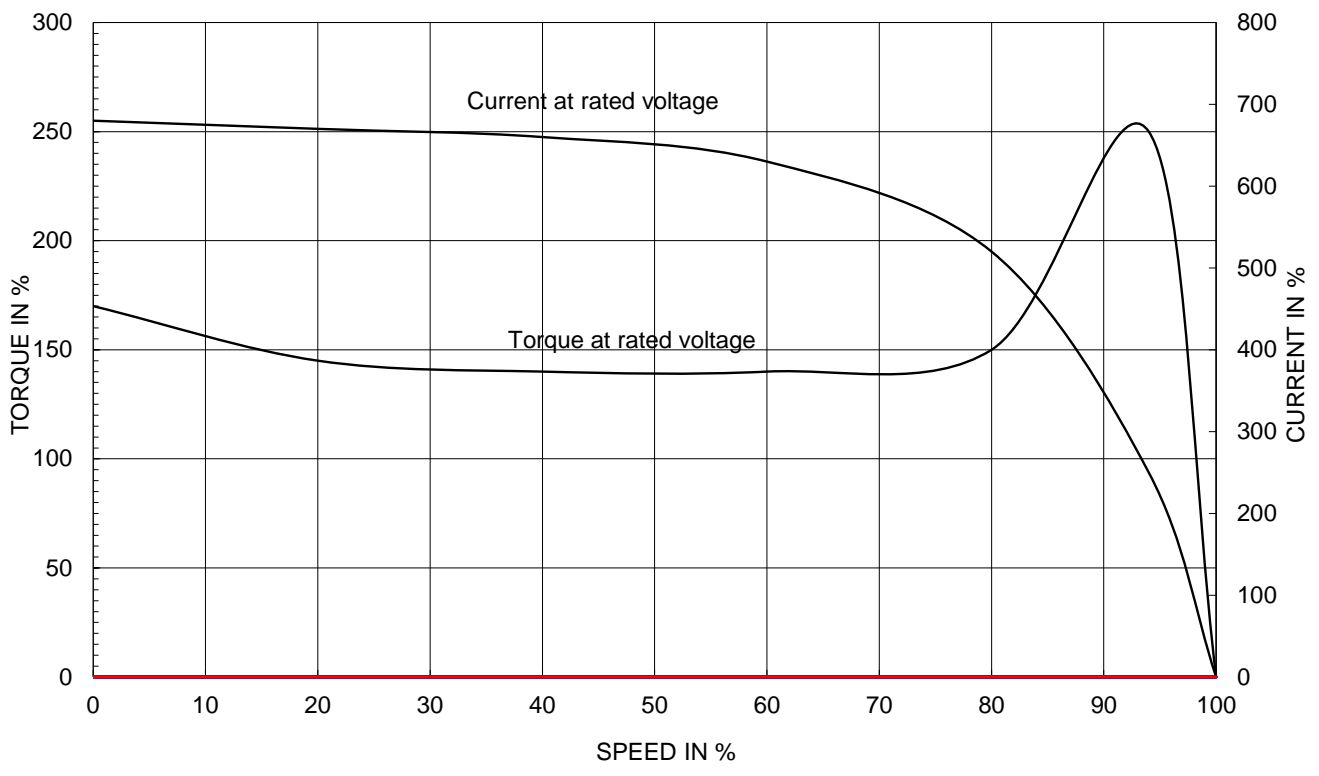

OUTPUT VS EFF., P.F & CURRENT CURVE

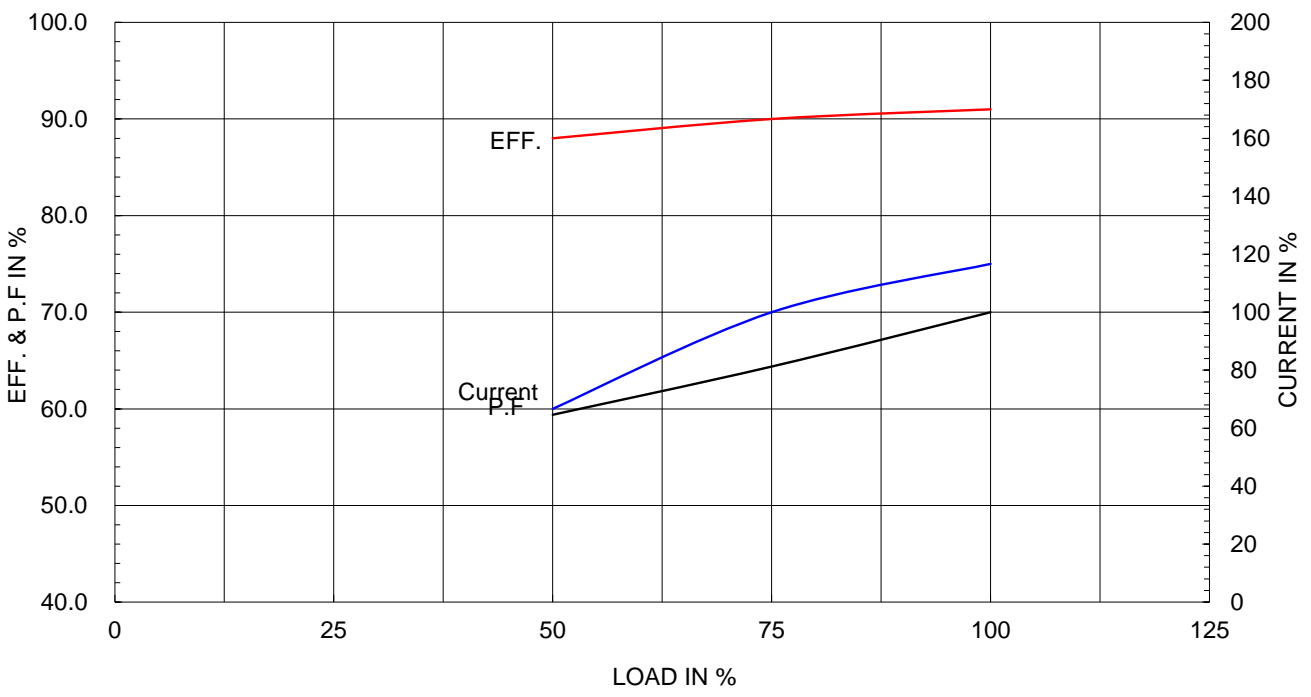

본 도면은 HD현대일렉트릭(주) 재산이며 허가없이 복사할 수 없음 (취급주의)

THIS DRAWING IS PROPRIETARY TO HYUNDAI ELECTRIC. NO PART OF THIS DRAWING MAY BE REPRODUCED WITHOUT THE PERMISSION OF HYUNDAI ELECTRIC.

1	2	3	4
▽	50S	REV	DATE
▽▽	12.5S		
▽▽▽	3.2S		
▽▽▽▽	0.4S		

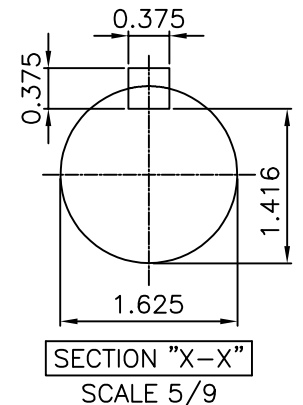
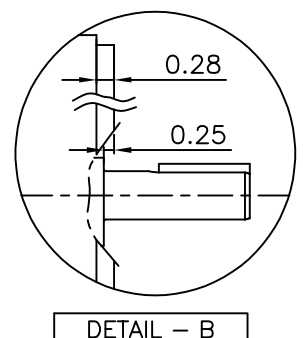
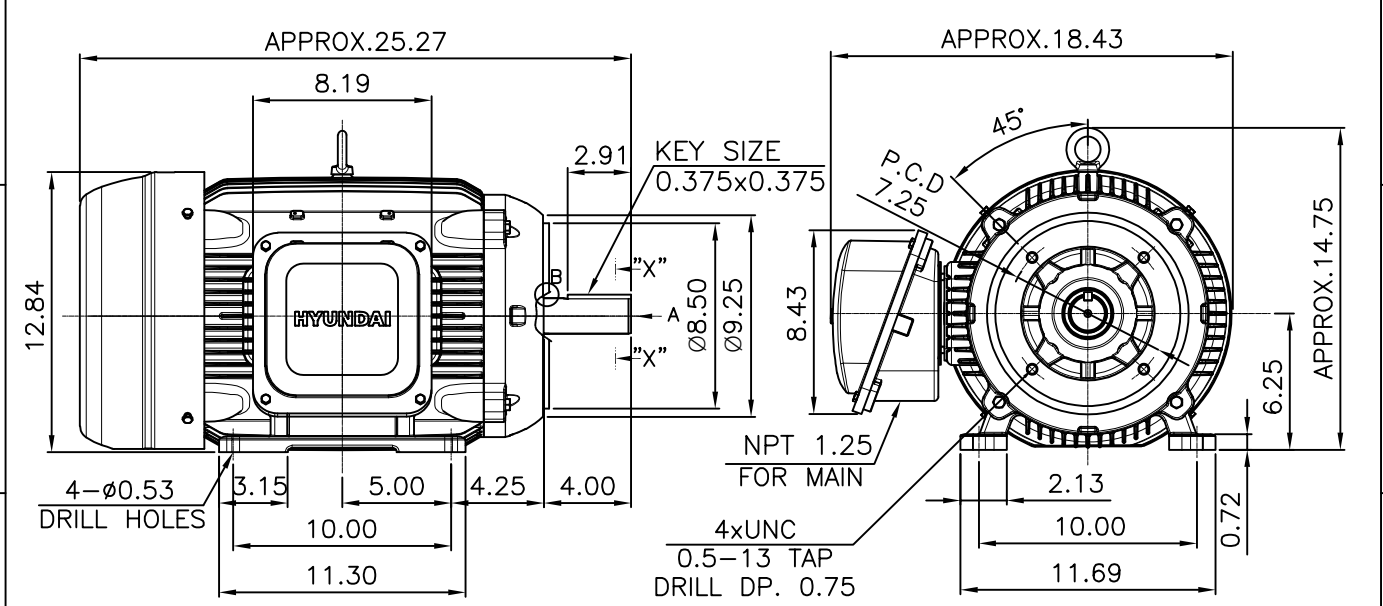

**NOTE**  
[TOLERANCE]

- CENTER HEIGHT : +0.00inch - 0.03inch
- SHAFT DIAMETER : +0.000inch - 0.001inch
- KEYWAY DEPTH : +0.000inch - 0.015inch

APPD BY	S.Y.KIM	UNIT	mm	SUBJECT	NEMA 256TC	DWG SIZE	A4 ( 19 )
CHKD BY	R.G.KIM	SCALE	1/9	TITLE <b>OUTLINE</b>			
CHKD BY		PROJEC'N	3rd Angle				
DSND BY	전지현	DATE	2021-04-29				
				REF. NO		Sheet No.	of
				DWG NO	LM-T2256C4PLV23	Revision No.	0



Cls. I&II, Div. 2  
IEEE 841



▽	50S
▽▽	12.5S
▽▽▽	3.2S
▽▽▽▽	0.4S

REV	DATE	CONTENTS	REVD BY	CHKD BY	CHKD BY	APPD BY

일반가공공차		일반제관공차	
1-4	±0.1	6-30	±0.5
4-18	±0.2	30-120	±0.8
18-63	±0.3	120-315	±1.2
63-250	±0.5	315-1000	±2.0
250-	±0.8	1000-	±3.0

Q'TY	DESCRIPTION	MATERIAL	DIMENSION	WEIGHT	PART NO.	REMARK	NO.
APPD BY	S.Y.KIM	UNIT	inch(mm)	SUBJECT	FR. 250-280 (CAST IRON)	DWG SIZE	
CHKD BY		SCALE	1/2	TITLE	TERMINAL BOX ASS'Y	A3 (1:2)	
CHKD BY	R.G.KIM	PROJEC'N	3rd Angle				
DSND BY	배승희	DATE	2023-10-19				
				REF. NO		Sheet No.	of
				DWG NO	3M-248458	Revision No.	0

