

Customer :
Project Name :
Project No. :
Revision No. :

SPECIFICATION for INDUCTION MOTOR



0		For Bidding			
No.	DATE	DESCRIPTION	PREPARED BY	CHECKED BY	APPROVED BY



AC INDUCTION MOTOR DATA SHEET

Catalog No.	HES5-18-184TC	Item No.		Rev. No.	[]
Project Name		Project No.		Quantity	sets

GENERAL SPECIFICATION			PERFORMANCE DATA			
Frame Size	184TC		Rated Output	3.7 kW 5 HP		
Type	PJP		Number of Poles	4		
Enclosure(Protection)	Totally Enclosed	/	IP55	Rotor Type	Squirrel Cage	
Method of Cooling	IC411(FC)		Starting Method*	D.O.L		
Rated Frequency	60 Hz		Rated Voltage	575 V	460 V	230 V
Number of Phases	3		Current	Full Load	5.19 A	6.49 A 12.97 A
Insulation Class	F			Locked-rotor**	840 %	840 % 840 %
Temp. Rise at full load (by resistance method)			Efficiency			
at 1.0 S.F	80 deg. C		50% Load		86.5 %	
Motor Location	<input type="checkbox"/> Indoor <input type="checkbox"/> Outdoor		75% Load		88.5 %	
Altitude	Less than 1,000 meter		100% Load		89.5 %	
Relative Humidity	Less than 80 %		Power Factor(p.u)			
Ambient Temp.	40 deg. C (Max.)		50% Load		0.650	
Duty Type	Continuous (S1)		75% Load		0.750	
Service Factor	1.15		100% Load		0.800	
Mounting	B35		Speed at Full Load	1760 r.p.m		
Bearing	Type	Anti-Friction		Torque		
	DE/N-DE	6206ZZC3 / 6206ZZC3		Full Load	14.8 lb.ft	
	Lubricant	Grease(Polyrex-EM)		Locked-rotor**	210 %	
External Thrust	Not applicable		Breakdown**	260 %		
Coupling Method	<input checked="" type="checkbox"/> Direct <input type="checkbox"/> V-belt		Moment of Inertia (J)			
Shaft Extension	Single		Load(Max.)		35.061 lb.ft2	
Terminal Box	Main	Cast Iron		Motor		0.309 lb.ft2
	Aux.	No		Sound Pressure Level (No-load & mean value at 1m from motor)		
Location	Refer to Outline Drawing				60 dB(A)	
Application			Vibration		3.8 mm/sec (peak)	
Area classification	Hazardous		Permissible number of consecutive starts		Cold 3 times Hot 2 times	
Type of Ex-Protection	Class I&II, Division 2		Paint	Munsell No.	4.0PB5.4/5.5(VL-451)	
Applicable Standard	NEMA MG1, CSA C390					

ACCESSORIES

SUBMITTAL DRAWING		
Outline Dimension Drawing	Motor Weight(Approx.)	
B35	LM-T2184C4PLV23	125 lb.

SPARE PARTS

REMARK				
1. Premium efficiency according to NEMA MG1 2. Inverter Duty @ 1.0 Service Factor & F Temperature rise -. 10:1 VT (20:1 VT at 50% load) -. 10:1 CT -. CHP up to 1.5 times base speed, NEMA MG1 Part31 3. CSA Certification -. Class I, Division 2, Group A, B, C & D -. Class II, Division 2 Group E, F & G (Group E : up to 320Fr.) 4. Service Factor 1.15 and Temperature rise B are applicable under the condition of sine wave power. 5. Service Factor 1.25 is applicable to motors of 100HP or less with temperature rise F & Non-Hazardous.				
Date	DSND	CHKD	CHKD	APPD
2024-07-13	S.H. Lee	I.K. Kim	R.G. Kim	S.W. Kim

[Note] Others not mentioned in this data sheet shall be in accordance with maker standard.
 Above technical data are only design values and shall be guaranteed with tolerance of applicable standard.
 Inspection and performance test shall be done according to maker standard, if not mentioned.
 * In case of Inverter-Fed Motor, performance data is based on sine wave tests. It may be different from test data of Inverter combined motor.
 ** Data is based on rated voltage & frequency and is expressed as a percentage of full-load value.

1	2	3	4
REV	DATE	CONTENTS	REVD BY

3.94

CROWN TRITON G2 Premium Efficiency AC 3 Phase Motor Cat. No. HES5-18-184TC

5HP	4P	230/460V	Amps	12.97/6.49	Type	HLS	Amb.	40°C	
Frame	184TC	Duty	CONT	Encl.	TEFC	Model	HLS184PR235	NEMA Nom. Eff. 89.5%	
RPM	1760	Hertz	60Hz	S.F.	1.15	INS. Class	F HD-F1	3/4 Eff. 88.5%	
Bearing	Drive	6206ZZC3	S.F.1.25 (When 100HP or less, Temp Rise F & Non-Hazardous)				NEMA Design	B Torque	
	Opp.	6206ZZC3	S.F.1.00 (10:1 C.T., 20:1 V.T., NEMA-MG1 Part31)				Code	K	
Usable at	50Hz 3HP 380V 6.1A 1470rpm S.F.: 1.0 Eff.: 84.3% Code: L								
	50Hz 3HP 400/415V 6.4/6.7A 1475/1475rpm S.F.: 1.0 Eff.: 84.3/84.3% Code: L/L								
CSA Certified for	Model	LATER	Type	PJP	Temp. Code	Frame	140-320FR	CE	
	CLASS I, Div. 2, Gr. A, B, C & D	CLASS II, Div. 2, Gr. E, F & G			(Sine Wave)	Amb.40°C	T3C (160°C)		
	CLASS I, Zone 2, Gr. IIA, IIB & IIC	(Gr. E: up to 320FR)				Amb.55°C	T3A (180°C)		
No.	-	Date	-	Weight	125 lb				
4M-136021		MARINE DUTY IEEE45		Made in Vietnam H4 Designed By HYUNDAI, Korea		HD HYUNDAI ELECTRIC		ABS APPROVED PRODUCT	

1.57

APPD BY	S.Y.KIM	UNIT	INCH	SUBJECT	CSA Class I, Division2 Severe Duty (HES, 143-215)	DWG SIZE
CHKD BY	I.K.KIM	SCALE	NONE			A4 (1:1)
CHKD BY	R.G.KIM	PROJEC'N	3rd Angle	TITLE NAMEPLATE DRAWING		
DSND BY	S.H.LEE	DATE	2024.06.07			
				REF. NO	4M-136021	Sheet No. of
				DWG NO	NP-HES5-18-184TC	Revision No. 0

Type :	PJP
Full Load Torque :	14.8 lb.ft
Load moment of Inertia (J) :	35.061 lb.ft ²
Motor moment of Inertia (J) :	0.309 lb.ft ²

3.7kW 5HP	4 P	60 Hz
Speed at Full Load :		1760 RPM
Rated Voltage	575V	460V 230V
Full Load Current	5.2A	6.5A 13.0A

SPEED VS TORQUE & CURRENT CURVE

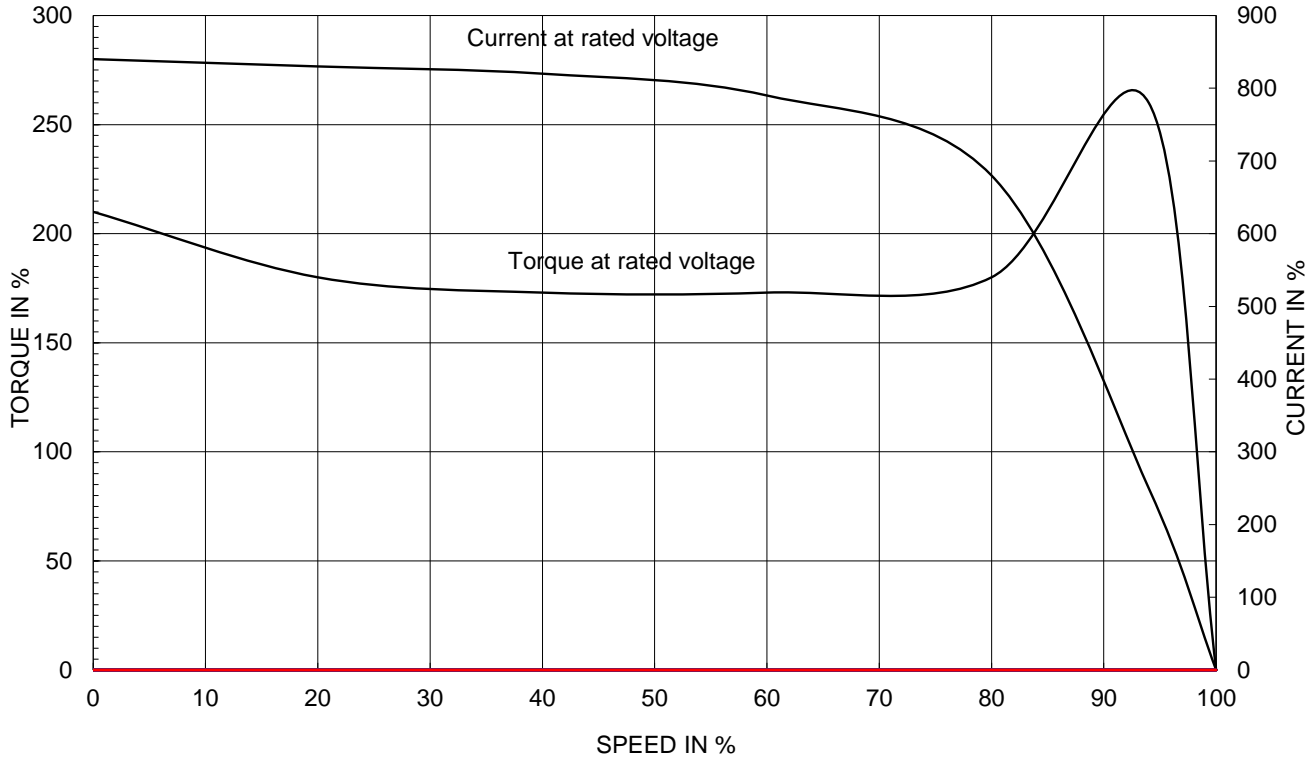

OUTPUT VS EFF., P.F & CURRENT CURVE

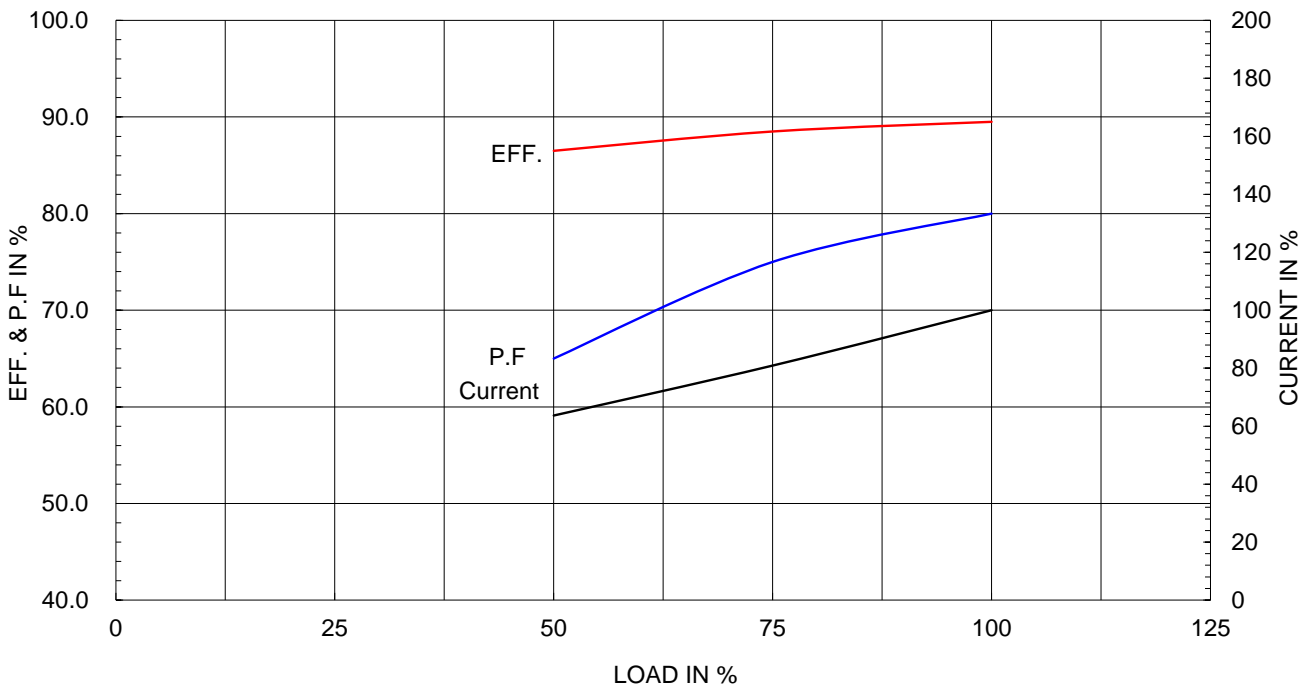

본 도면은 HD현대일렉트릭(주) 재산이며 허가없이 복사할 수 없음 (취급유의)

THIS DRAWING IS PROPRIETARY TO HYUNDAI ELECTRIC. NO PART OF THIS DRAWING MAYBE REPRODUCED WITHOUT THE PERMISSION OF HYUNDAI ELECTRIC.

▽	50S	REV	DATE	CONTENTS	REVD BY	CHKD BY	CHKD BY	APPD BY
▽▽	12.5S							
▽▽▽	3.2S							
▽▽▽▽	0.4S							

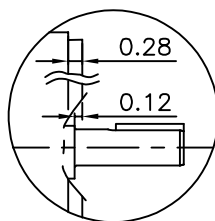
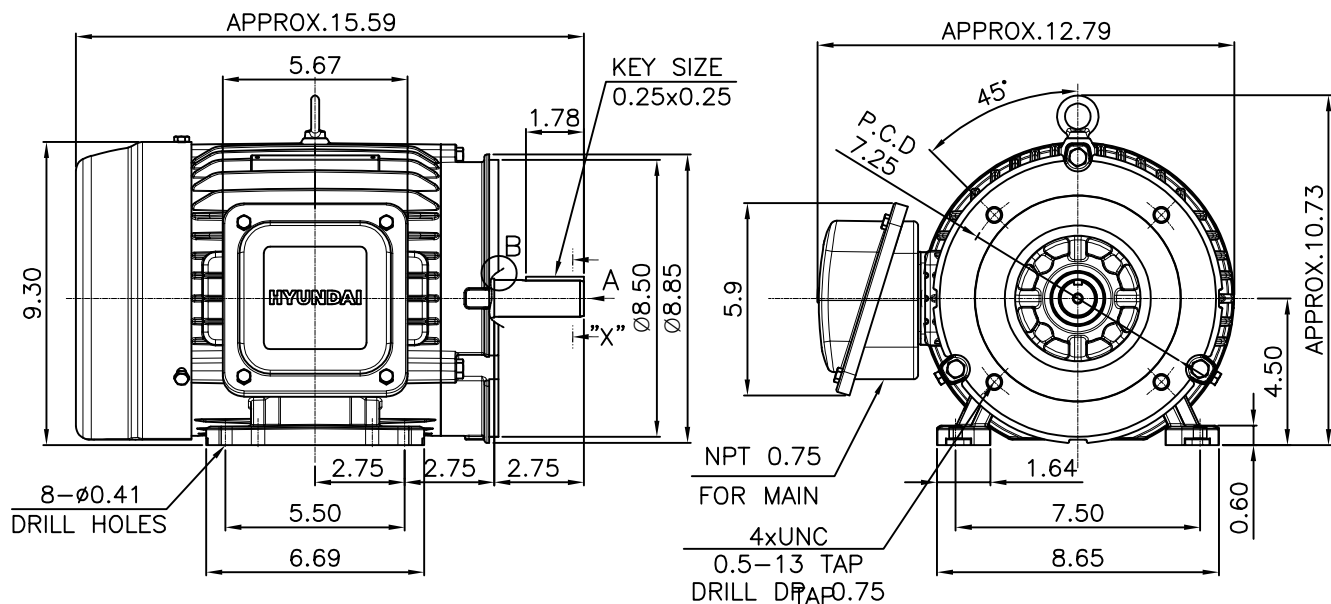

DETAIL - B

NOTE

[TOLERANCE]

- CENTER HEIGHT : +0.00inch - 0.03inch
- SHAFT DIAMETER : +0.000inch - 0.0005inch
- KEYWAY DEPTH : +0.000inch - 0.015inch

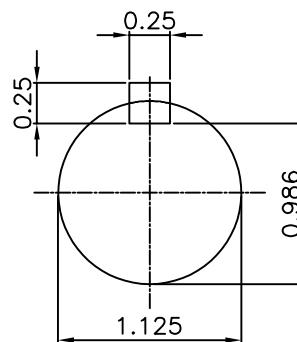

SECTION "X-X"

SCALE 5/6

APPD BY	S.Y.KIM	UNIT	mm	SUBJECT	NAMA 184TC	DWG SIZE	A4 (1:6)
CHKD BY	R.G.KIM	SCALE	1/6	TITLE	OUTLINE		
CHKD BY		PROJEC'N	3rd Angle	REF. NO		Sheet No.	of
DSND BY	주유림	DATE	2021-04-29	DWG NO	LM-T2184C4PLV23	Revision No.	0

**Cls. I&II, Div. 2
IEEE 841**

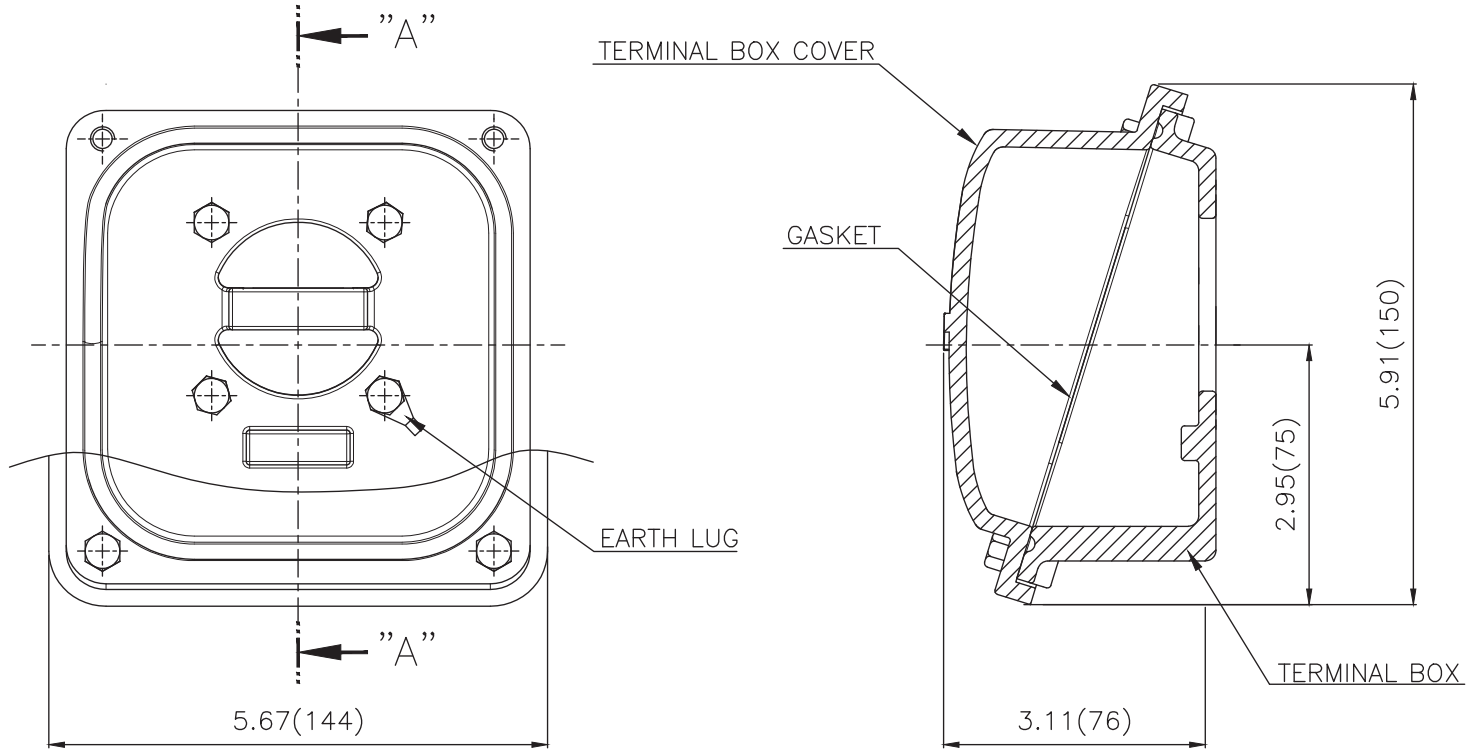

SEC. "A"-"A"

▽	50S
▽▽	12.5S
▽▽▽	3.2S
▽▽▽▽	0.4S

REV	DATE	CONTENTS	REVD BY	CHKD BY	CHKD BY	APPD BY

일반가공공차		일반제관공차	
1-4	±0.1	6-30	±0.5
4-18	±0.2	30-120	±0.8
18-63	±0.3	120-315	±1.2
63-250	±0.5	315-1000	±2.0
250-	±0.8	1000-	±3.0

Q'TY	DESCRIPTION	MATERIAL	DIMENSION	WEIGHT	PART NO.	REMARK	NO.
APPD BY	S.Y.KIM	UNIT	inch(mm)	SUBJECT	FR. 140-180 (CAST IRON)	DWG SIZE	A3 (1:1.5)
CHKD BY		SCALE	1/1.5	TITLE			
CHKD BY	R.G.KIM	PROJEC'N	3rd Angle	TERMINAL BOX ASS'Y			
DSND BY	배승희	DATE	2023-10-19	REF. NO		Sheet No.	of
				DWG NO	3M-248456	Revision No.	0

