

Customer :  
Project Name :  
Project No. :  
Revision No. :

# SPECIFICATION for INDUCTION MOTOR



0		For Bidding			
No.	DATE	DESCRIPTION	PREPARED BY	CHECKED BY	APPROVED BY



# AC INDUCTION MOTOR DATA SHEET

Catalog No.	HES3-12-213TC	Item No.		Rev. No.	[      ]
Project Name		Project No.		Quantity	sets

GENERAL SPECIFICATION			PERFORMANCE DATA			
Frame Size	213TC		Rated Output	2.2 kW		3 HP
Type	PJP		Number of Poles	6		
Enclosure(Protection)	Totally Enclosed	/ IP55	Rotor Type	Squirrel Cage		
Method of Cooling	IC411(FC)		Starting Method*	D.O.L		
Rated Frequency	60 Hz		Rated Voltage	575 V	460 V	230 V
Number of Phases	3		Current	Full Load	3.68 A	4.60 A
Insulation Class	F			Locked-rotor**	770 %	770 %
Temp. Rise at full load (by resistance method)			Efficiency			
at 1.0 S.F	80 deg. C		50% Load		86.5 %	
Motor Location	<input type="checkbox"/> Indoor <input type="checkbox"/> Outdoor		75% Load		88.5 %	
Altitude	Less than 1,000 meter		100% Load		89.5 %	
Relative Humidity	Less than 80 %		Power Factor(p.u)			
Ambient Temp.	40 deg. C (Max.)		50% Load		0.520	
Duty Type	Continuous ( S1 )		75% Load		0.620	
Service Factor	1.15		100% Load		0.670	
Mounting	B35		Speed at Full Load	1185 r.p.m		
Bearing	Type	Anti-Friction	Torque			
	DE/N-DE	6208ZZC3 / 6208ZZC3	Full Load		13.1 lb.ft	
	Lubricant	Grease(Polyrex-EM)	Locked-rotor**		180 %	
External Thrust	Not applicable		Breakdown**		250 %	
Coupling Method	<input checked="" type="checkbox"/> Direct <input type="checkbox"/> V-belt		Moment of Inertia (J)			
Shaft Extension	Single		Load(Max.)		55.860 lb.ft2	
Terminal Box	Main	Cast Iron	Motor		0.949 lb.ft2	
	Aux.	No	Sound Pressure Level (No-load & mean value at 1m from motor)			
Location	Refer to Outline Drawing				57 dB(A)	
Application			Vibration		3.8 mm/sec (peak)	
Area classification	Hazardous		Permissible number of consecutive starts		Cold 3 times Hot 2 times	
Type of Ex-Protection	Class I&II, Division 2		Paint	Munsell No.	4.0PB5.4/5.5(VL-451)	
Applicable Standard	NEMA MG1, CSA C390					

ACCESSORIES

SUBMITTAL DRAWING			
Outline Dimension Drawing		Motor Weight(Approx.)	
B35	LM-T2213C4PLV23	170 lb.	

SPARE PARTS

REMARK				
1. Premium efficiency according to NEMA MG1 2. Inverter Duty @ 1.0 Service Factor & F Temperature rise -. 10:1 VT (20:1 VT at 50% load) -. 10:1 CT -. CHP up to 1.5 times base speed, NEMA MG1 Part31 3. CSA Certification -. Class I, Division 2, Group A, B, C & D -. Class II, Division 2 Group E, F & G (Group E : up to 320Fr.) 4. Service Factor 1.15 and Temperature rise B are applicable under the condition of sine wave power. 5. Service Factor 1.25 is applicable to motors of 100HP or less with temperature rise F & Non-Hazardous.				
Date	DSND	CHKD	CHKD	APPD
2024-07-13	S.H. Lee	I.K. Kim	R.G. Kim	S.W. Kim

[Note] Others not mentioned in this data sheet shall be in accordance with maker standard.  
 Above technical data are only design values and shall be guaranteed with tolerance of applicable standard.  
 Inspection and performance test shall be done according to maker standard, if not mentioned.  
 \* In case of Inverter-Fed Motor, performance data is based on sine wave tests. It may be different from test data of Inverter combined motor.  
 \*\* Data is based on rated voltage & frequency and is expressed as a percentage of full-load value.

1	2	3	4
REV	DATE	CONTENTS	REVD BY

3.94

**CROWN TRITON G2** Premium Efficiency AC 3 Phase Motor Cat. No. HES3-12-213TC

3HP	6P	230/460V	Amps	9.21/4.6	Type	HLS	Amb.	40°C	
Frame	213TC	Duty	CONT	Encl.	TEFC	Model	HLS213PR335	NEMA Nom. Eff.	89.5%
RPM	1185	Hertz	60Hz	S.F.	1.15	INS. Class	F HD-F1	3/4 Eff.	88.5%
Bearing	Drive	6208ZZC3	S.F.1.25 (When 100HP or less, Temp Rise F & Non-Hazardous)				NEMA Design	B Torque	
	Opp.	6208ZZC3	S.F.1.00 (10:1 C.T., 20:1 V.T., NEMA-MG1 Part31)				Code	L	
Usable at	50Hz 2HP 380V 5.5A 985rpm S.F.: 1.0 Eff.: 79.8% Code: L								
	50Hz 2HP 400/415V 5.9/6.3A 985/985rpm S.F.: 1.0 Eff.: 79.8/79.8% Code: L/L								
CSA Certified for	Model	LATER	Type	PJP	Temp. Code	Frame	140-320FR	CE	
	CLASS I, Div. 2, Gr. A, B, C & D		CLASS II, Div. 2, Gr. E, F & G		(Sine Wave)	Amb.40°C	T3C (160°C)		
	CLASS I, Zone 2, Gr. IIA, IIB & IIC		(Gr. E: up to 320FR)			Amb.55°C	T3A (180°C)		
No.	-	Date	-	Weight	170 lb				

CC038A

**MARINE DUTY IEEE45**
  
4M-136021
  
Made in Vietnam H4
  
Designed By HYUNDAI, Korea

1.57

APPD BY	S.Y.KIM	UNIT	INCH	SUBJECT	CSA Class I, Division2 Severe Duty (HES, 143-215)	DWG SIZE	A4 ( 1:1 )
CHKD BY	I.K.KIM	SCALE	NONE				
CHKD BY	R.G.KIM	PROJEC'N	3rd Angle	TITLE <b>NAMEPLATE DRAWING</b>			
DSND BY	S.H.LEE	DATE	2024.06.07				
				REF. NO	<b>4M-136021</b>	Sheet No.	of
				DWG NO	<b>NP-HES3-12-213TC</b>	Revision No.	<b>0</b>

Type :	PJP
Full Load Torque :	13.1 lb.ft
Load moment of Inertia (J) :	55.860 lb.ft <sup>2</sup>
Motor moment of Inertia (J) :	0.949 lb.ft <sup>2</sup>

2.2kW	3HP	6 P	60 Hz
Speed at Full Load :			1185 RPM
Rated Voltage	575V	460V	230V
Full Load Current	3.7A	4.6A	9.2A

SPEED VS TORQUE & CURRENT CURVE

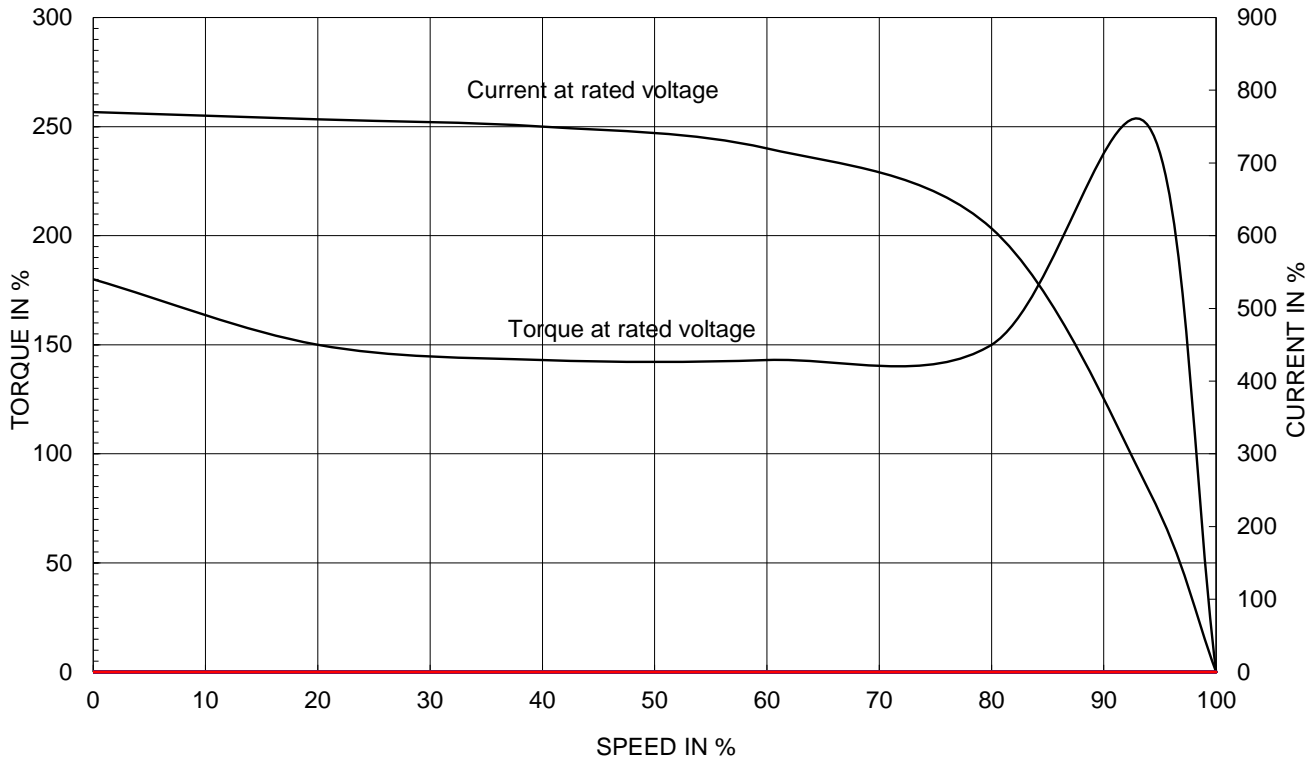

OUTPUT VS EFF., P.F & CURRENT CURVE

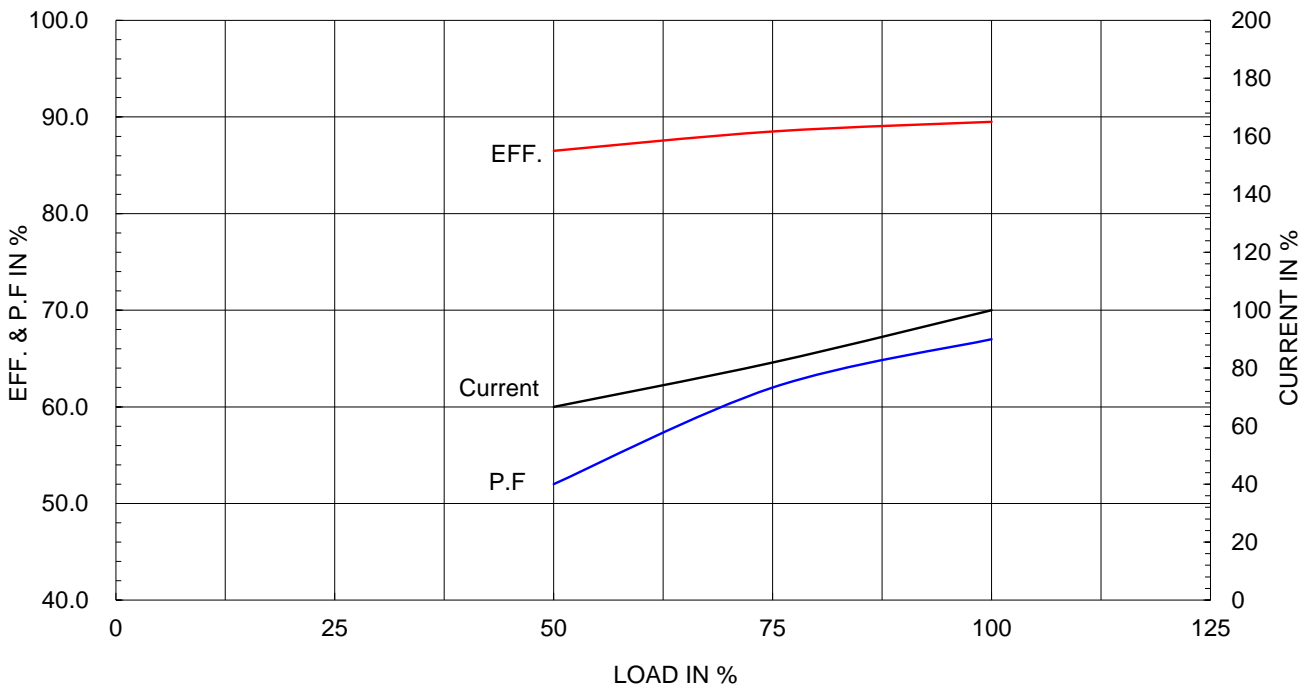

본 도면은 HD현대일렉트릭(주) 재산이며 허가없이 복사할 수 없음 (취급주의)

THIS DRAWING IS PROPRIETARY TO HYUNDAI ELECTRIC. NO PART OF THIS DRAWING MAYBE REPRODUCED WITHOUT THE PERMISSION OF HYUNDAI ELECTRIC.

▽	50S	REV	DATE	CONTENTS	REVD BY	CHKD BY	CHKD BY	APPD BY
▽▽	12.5S							
▽▽▽	3.2S							
▽▽▽▽	0.4S							

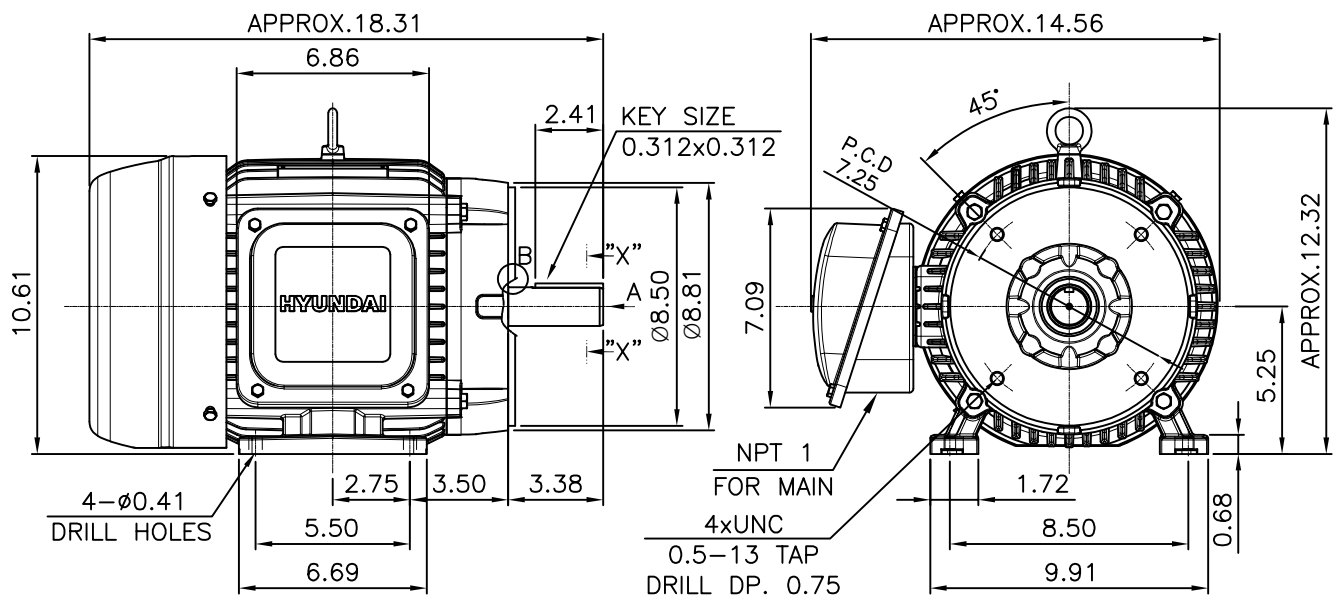

VIEW "A"

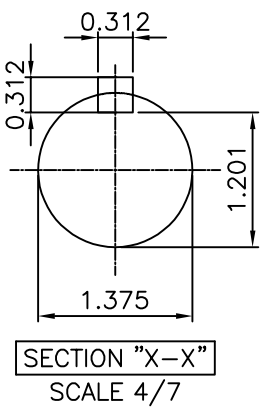
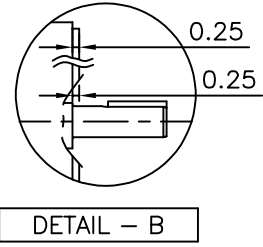

**NOTE**

[TOLERANCE]

1. CENTER HEIGHT : +0.00inch - 0.03inch
2. SHAFT DIAMETER : +0.000inch - 0.0005inch
3. KEYWAY DEPTH : +0.000inch - 0.015inch

APPD BY	S.Y.KIM	UNIT	mm	SUBJECT	NEMA 213TC	DWG SIZE	
CHKD BY	R.G.KIM	SCALE	1/7	TITLE	OUTLINE	A4 ( 1:7 )	
CHKD BY		PROJEC'N	3rd Angle				
DSND BY	주유림	DATE	2021-04-29				
				REF. NO	.	Sheet No.	of
				DWG NO	LM-T2213C4PLV23	Revision No.	0

Cls. I&II, Div. 2  
IEEE 841



SEC. "A" - "A"

▽	50S
▽▽	12.5S
▽▽▽	3.2S
▽▽▽▽	0.4S

REV	DATE	CONTENTS	REVD BY	CHKD BY	CHKD BY	APPD BY

일반기공공차		일반재관공차	
1-4	±0.1	6-30	±0.5
4-18	±0.2	30-120	±0.8
18-63	±0.3	120-315	±1.2
63-250	±0.5	315-1000	±2.0
250-	±0.8	1000-	±3.0

Q'TY	DESCRIPTION	MATERIAL	DIMENSION	WEIGHT	PART NO.	REMARK	NO.
APPD BY	S.Y.KIM	UNIT	inch(mm)	SUBJECT	FR. 210 (CAST IRON)	DWG SIZE	A3 (1:1.5)
CHKD BY		SCALE	1/1.5	TITLE			
CHKD BY	R.G.KIM	PROJEC'N	3rd Angle	TERMINAL BOX ASS'Y			
DSND BY	배승희	DATE	2023-10-19	REF. NO		Sheet No.	of
				DWG NO	3M-248457	Revision No.	0

