

Customer :  
Project Name :  
Project No. :  
Revision No. :

# SPECIFICATION for INDUCTION MOTOR



0		For Bidding			
No.	DATE	DESCRIPTION	PREPARED BY	CHECKED BY	APPROVED BY



# AC INDUCTION MOTOR DATA SHEET

Catalog No.	HES30-18-286T	Item No.		Rev. No.	[ ]
Project Name		Project No.		Quantity	sets

GENERAL SPECIFICATION		PERFORMANCE DATA				
Frame Size	286T	Rated Output	22 kW	30 HP		
Type	PJP	Number of Poles	4			
Enclosure(Protection)	Totally Enclosed / IP55	Rotor Type	Squirrel Cage			
Method of Cooling	IC411(FC)	Starting Method*	D.O.L			
Rated Frequency	60 Hz	Rated Voltage	575 V	460 V	230 V	
Number of Phases	3	Current	Full Load	29.1 A	36.4 A	
Insulation Class	F		Locked-rotor**	740 %	740 %	740 %
Temp. Rise at full load (by resistance method)		Efficiency				
at 1.0 S.F	80 deg. C	50% Load		90.6 %		
Motor Location	<input type="checkbox"/> Indoor <input type="checkbox"/> Outdoor	75% Load		92.6 %		
Altitude	Less than 1,000 meter	100% Load		93.6 %		
Relative Humidity	Less than 80 %	Power Factor(p.u)				
Ambient Temp.	40 deg. C (Max.)	50% Load		0.660		
Duty Type	Continuous ( S1 )	75% Load		0.760		
Service Factor	1.15	100% Load		0.810		
Mounting	B3	Speed at Full Load		1775 r.p.m		
Bearing	Type	Anti-Friction				
	DE/N-DE	6310ZC3 / 6310ZC3				
	Lubricant	Grease(Polyrex-EM)				
External Thrust	Not applicable					
Coupling Method	<input checked="" type="checkbox"/> Direct <input type="checkbox"/> V-belt	Torque				
Shaft Extension	Single	Full Load		87.3 lb.ft		
Terminal Box	Main	Locked-rotor**		170 %		
	Aux.	Breakdown**		220 %		
Location	Refer to Outline Drawing	Moment of Inertia (J)				
Application		Load(Max.)		160.272 lb.ft2		
Area classification	Hazardous	Motor		5.578 lb.ft2		
Type of Ex-Protection	Class I&II, Division 2	Sound Pressure Level (No-load & mean value at 1m from motor)				
Applicable Standard	NEMA MG1, CSA C390			72 dB(A)		
<b>ACCESSORIES</b>		<b>SUBMITTAL DRAWING</b>				
		Outline Dimension Drawing		Motor Weight(Approx.)		
		B3	LM-T2286B3PLV23	410 lb.		
		<b>REMARK</b>				
		1. Premium efficiency according to NEMA MG1 2. Inverter Duty @ 1.0 Service Factor & F Temperature rise -. 10:1 VT (20:1 VT at 50% load) -. 10:1 CT -. CHP up to 1.5 times base speed, NEMA MG1 Part31 3. CSA Certification -. Class I, Division 2, Group A, B, C & D -. Class II, Division 2 Group E, F & G (Group E : up to 320Fr.) 4. Service Factor 1.15 and Temperature rise B are applicable under the condition of sine wave power. 5. Service Factor 1.25 is applicable to motors of 100HP or less with temperature rise F & Non-Hazardous.				
<b>SPARE PARTS</b>		Date	DSND	CHKD	CHKD	APPD
		2024-07-13	S.H. Lee	I.K. Kim	R.G. Kim	S.W. Kim

[Note] Others not mentioned in this data sheet shall be in accordance with maker standard.  
 Above technical data are only design values and shall be guaranteed with tolerance of applicable standard.  
 Inspection and performance test shall be done according to maker standard, if not mentioned.  
 \* In case of Inverter-Fed Motor, performance data is based on sine wave tests. It may be different from test data of Inverter combined motor.  
 \*\* Data is based on rated voltage & frequency and is expressed as a percentage of full-load value.

1	2	3	4
REV	DATE	CONTENTS	REVD BY   CHKD BY   CHKD BY   APPD BY

4.72

**CROWN TRITON G2**     

**Premium Efficiency AC 3 Phase Motor**

30HP	4P	230/460V	Cat. No.	HES30-18-286T						
Model	HLS286SR23		INS. Class	F	HD-F1	Amps	72.8/36.4			
Type	HLS	Duty	CONT	Code	J	Amb.	40°C	Hertz	60Hz	
Frame	286T	Encl.	TEFC	S.F.	1.15	RPM	1775	NEMA Norm. Eff.	93.6%	
Bearing	Drive	6310ZC3		S.F.1.25 (When 100HP or less, Temp Rise F & Non-Hazardous)		3/4 Eff.	92.6%			
	Opp.	6310ZC3		S.F.1.00 (10:1 C.T., 20:1 V.T., NEMA-MG1 Part31)		NEMA Design	B Torque			
Usable at	50Hz 25HP 380V 42.4A 1475rpm S.F.: 1.0 Eff.: 91.2% Code: J									
	50Hz 25HP 400/415V 42.3/43.1A 1480/1480rpm S.F.: 1.0 Eff.: 91.2/91.2% Code: K/L									
CSA Certified for	Model	LATER		Type	PJP	Temp. Code	Frame	140~320FR	360~400FR	440FR
	CLASS I, Div. 2, Gr. A, B, C & D CLASS I, Zone 2, Gr. IIA, IIB, & IIC	CLASS II, Div. 2 Gr. E, F & G (Gr. E: Up to 320FR)		(sine wave)	Amb. 40°C	T3C (160°C)	T3B (165°C)	T3A (180°C)		
					Amb. 55°C	T3A (180°C)	T3A (180°C)	T3 (200°C)		
No.	-	Date	-	Weight	410 lb					

 4M-136024  
**MARINE DUTY IEEE45**
Made in Vietnam H4  
Designed By HYUNDAI, Korea
 **HD HYUNDAI ELECTRIC**

2.36

APPD BY	S.Y.KIM	UNIT	INCH	SUBJECT	CSA Class I, Division2 Severe Duty (HES, 254-326)	DWG SIZE
CHKD BY	I.K.KIM	SCALE	NONE			A4 ( 1:1 )
CHKD BY	R.G.KIM	PROJEC'N	3rd Angle	TITLE <b>NAMEPLATE DRAWING</b>		
DSND BY	S.H.LEE	DATE	2024.06.07			
	REF. NO	<b>4M-136024</b>		Sheet No. of		
	DWG NO	<b>NP-HES30-18-286T</b>		Revision No. <b>0</b>		

Type :	PJP
Full Load Torque :	87.3 lb.ft
Load moment of Inertia (J) :	160.272 lb.ft2
Motor moment of Inertia (J) :	5.578 lb.ft2

22kW	30HP	4 P	60 Hz
Speed at Full Load :			1775 RPM
Rated Voltage	575V	460V	230V
Full Load Current	29.1A	36.4A	72.8A

SPEED VS TORQUE & CURRENT CURVE

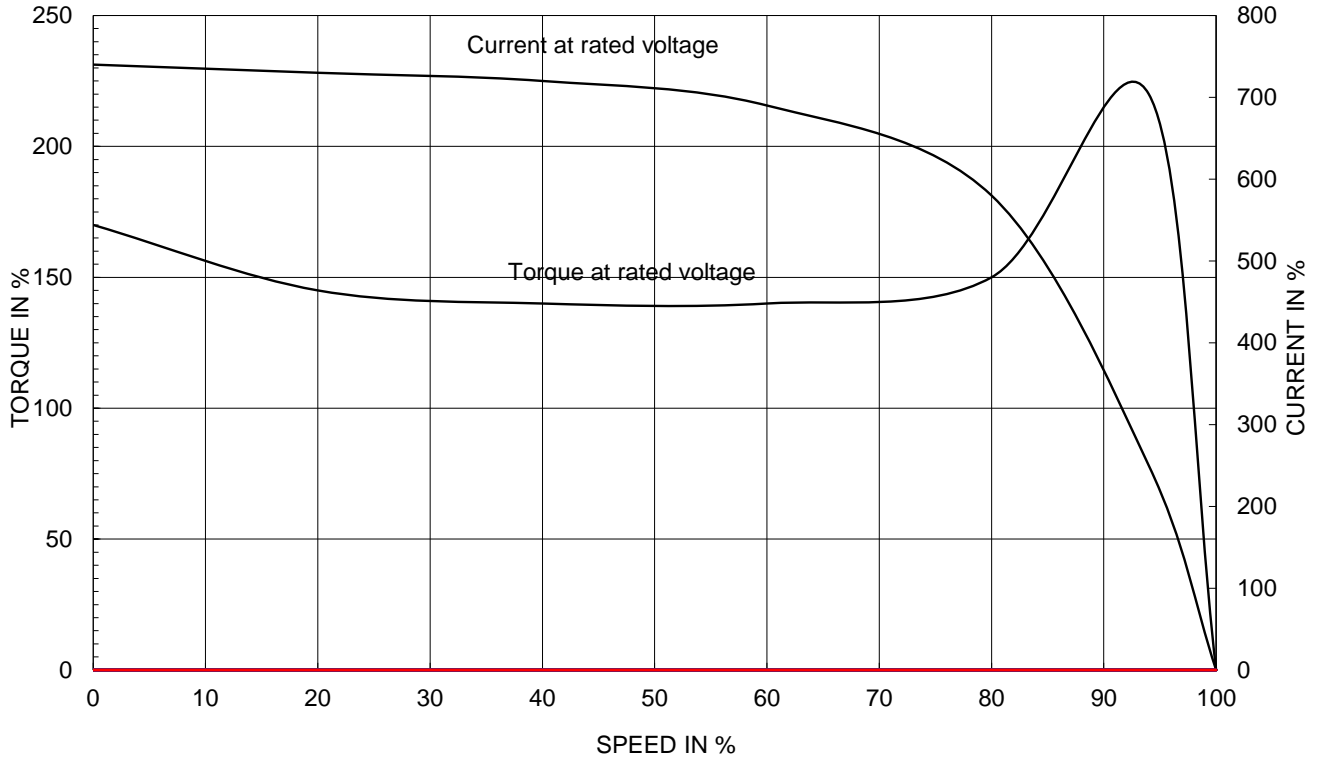

OUTPUT VS EFF., P.F & CURRENT CURVE

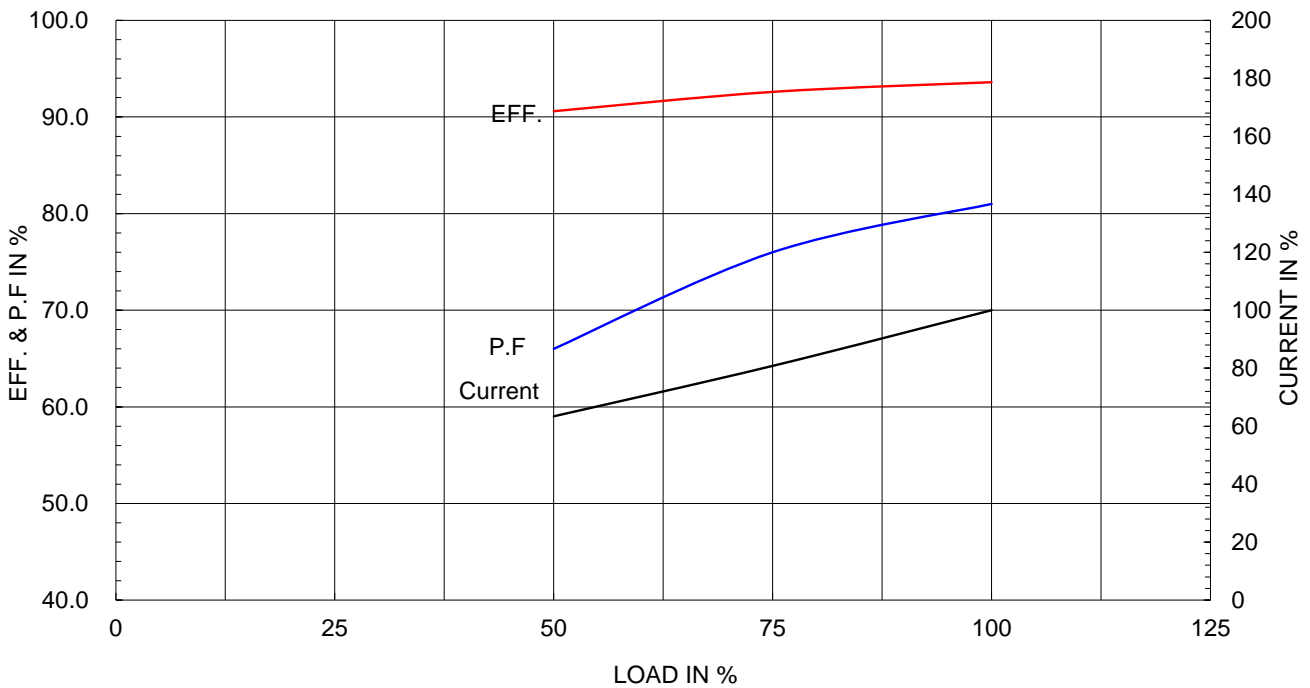

본 도면은 HD현대일렉트릭(주) 재산이며 허가없이 복사할 수 없음 (취급유의)

THIS DRAWING IS PROPRIETARY TO HYUNDAI ELECTRIC. NO PART OF THIS DRAWING MAY BE REPRODUCED WITHOUT THE PERMISSION OF HYUNDAI ELECTRIC.

▽	50S	REV	DATE	CONTENTS	REVD BY	CHKD BY	CHKD BY	APPD BY
▽▽	12.5S							
▽▽▽	3.2S							
▽▽▽▽	0.4S							

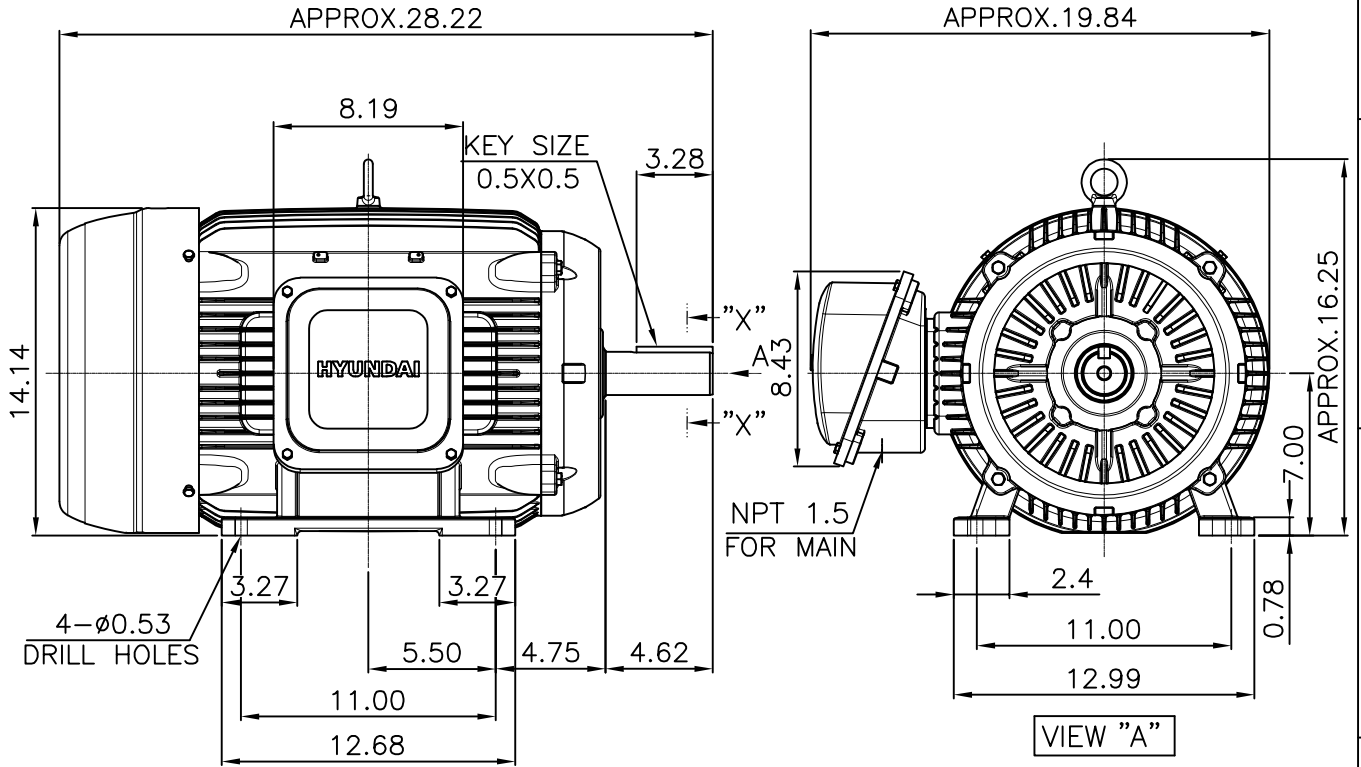

**NOTE**

[TOLERANCE]

- CENTER HEIGHT : +0.00inch - 0.03inch
- SHAFT DIAMETER : +0.000inch - 0.001inch
- KEYWAY DEPTH : +0.000inch - 0.015inch

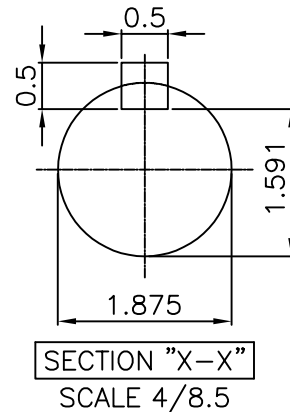

APPD BY	S.Y.KIM	UNIT	mm	SUBJECT	NEMA 286T	DWG SIZE	A4 ( 1:8.5 )
CHKD BY	R.G.KIM	SCALE	1/8.5	TITLE <b>OUTLINE</b>			
CHKD BY		PROJEC'N	3rd Angle				
DSND BY	주유림	DATE	2021-04-28				
				REF. NO	.	Sheet No.	of
				DWG NO	LM-T2286B3PLV23	Revision No.	0



Cls. I&II, Div. 2  
IEEE 841



▽	50S
▽▽	12.5S
▽▽▽	3.2S
▽▽▽▽	0.4S

REV	DATE	CONTENTS	REVD BY	CHKD BY	CHKD BY	APPD BY

일반가공공차		일반제관공차	
1-4	±0.1	6-30	±0.5
4-18	±0.2	30-120	±0.8
18-63	±0.3	120-315	±1.2
63-250	±0.5	315-1000	±2.0
250-	±0.8	1000-	±3.0

Q'TY	DESCRIPTION	MATERIAL	DIMENSION	WEIGHT	PART NO.	REMARK	NO.
APPD BY	S.Y.KIM	UNIT	inch(mm)	SUBJECT	FR. 250-280 (CAST IRON)	DWG SIZE	
CHKD BY		SCALE	1/2	TITLE	TERMINAL BOX ASS'Y		
CHKD BY	R.G.KIM	PROJEC'N	3rd Angle	DATE	2023-10-19		
DSND BY	배승희						
REF. NO		Sheet No.	of				
DWG NO	3M-248458	Revision No.	0				

