

Customer :  
Project Name :  
Project No. :  
Revision No. :

# SPECIFICATION for INDUCTION MOTOR



0		For Bidding			
No.	DATE	DESCRIPTION	PREPARED BY	CHECKED BY	APPROVED BY



# AC INDUCTION MOTOR DATA SHEET

Catalog No.	HES25-18-284T	Item No.		Rev. No.	[     ]
Project Name		Project No.		Quantity	sets

GENERAL SPECIFICATION			PERFORMANCE DATA			
Frame Size	284T		Rated Output	18.5 kW      25 HP		
Type	PJP		Number of Poles	4		
Enclosure(Protection)	Totally Enclosed	/	IP55	Rotor Type	Squirrel Cage	
Method of Cooling	IC411(FC)		Starting Method*	D.O.L		
Rated Frequency	60 Hz		Rated Voltage	575 V	460 V	230 V
Number of Phases	3		Current	Full Load	24.5 A	30.6 A      61.3 A
Insulation Class	F			Locked-rotor**	790 %	790 %      790 %
Temp. Rise at full load (by resistance method)			Efficiency			
at 1.0 S.F	80 deg. C		50% Load		90.6 %	
Motor Location	<input type="checkbox"/> Indoor <input type="checkbox"/> Outdoor		75% Load		92.6 %	
Altitude	Less than 1,000 meter		100% Load		93.6 %	
Relative Humidity	Less than 80 %		Power Factor(p.u)			
Ambient Temp.	40 deg. C (Max.)		50% Load		0.660	
Duty Type	Continuous ( S1 )		75% Load		0.760	
Service Factor	1.15		100% Load		0.810	
Mounting	B3		Speed at Full Load	1775 r.p.m		
Bearing	Type	Anti-Friction		Torque		
	DE/N-DE	6310ZC3 / 6310ZC3		Full Load	73.4 lb.ft	
	Lubricant	Grease(Polyrex-EM)		Locked-rotor**	170 %	
External Thrust	Not applicable		Breakdown**	220 %		
Coupling Method	<input checked="" type="checkbox"/> Direct <input type="checkbox"/> V-belt		Moment of Inertia (J)			
Shaft Extension	Single		Load(Max.)		141.396 lb.ft2	
Terminal Box	Main	Cast Iron		Motor		3.940 lb.ft2
	Aux.	No		Sound Pressure Level (No-load & mean value at 1m from motor)		
Location	Refer to Outline Drawing				72 dB(A)	
Application			Vibration		3.8 mm/sec (peak)	
Area classification	Hazardous		Permissible number of consecutive starts		Cold      3 times Hot      2 times	
Type of Ex-Protection	Class I&II, Division 2		Paint	Munsell No.	4.0PB5.4/5.5(VL-451)	
Applicable Standard	NEMA MG1, CSA C390					

ACCESSORIES

SUBMITTAL DRAWING			
Outline Dimension Drawing		Motor Weight(Approx.)	
B3	LM-T2284B3PLV23	360 lb.	

SPARE PARTS

REMARK				
1. Premium efficiency according to NEMA MG1 2. Inverter Duty @ 1.0 Service Factor & F Temperature rise -. 10:1 VT (20:1 VT at 50% load) -. 10:1 CT -. CHP up to 1.5 times base speed, NEMA MG1 Part31 3. CSA Certification -. Class I, Division 2, Group A, B, C & D -. Class II, Division 2 Group E, F & G (Group E : up to 320Fr.) 4. Service Factor 1.15 and Temperature rise B are applicable under the condition of sine wave power. 5. Service Factor 1.25 is applicable to motors of 100HP or less with temperature rise F & Non-Hazardous.				
Date	DSND	CHKD	CHKD	APPD
2024-07-13	S.H. Lee	I.K. Kim	R.G. Kim	S.W. Kim

[Note] Others not mentioned in this data sheet shall be in accordance with maker standard.  
 Above technical data are only design values and shall be guaranteed with tolerance of applicable standard.  
 Inspection and performance test shall be done according to maker standard, if not mentioned.  
 \* In case of Inverter-Fed Motor, performance data is based on sine wave tests. It may be different from test data of Inverter combined motor.  
 \*\* Data is based on rated voltage & frequency and is expressed as a percentage of full-load value.

1	2	3	4
REV	DATE	CONTENTS	REVD BY

4.72

**CROWN TRITON G2**

Premium Efficiency AC 3 Phase Motor







25HP	4P	230/460V	Cat. No.	HES25-18-284T			
Model	HLS284SR23		INS. Class	F	HD-F1	Amps	61.3/30.6
Type	HLS	Duty	CONT	Code	J	Amb.	40°C
Frame	284T	Encl.	TEFC	S.F.	1.15	RPM	1775
Bearing	Drive	6310ZC3		S.F.1.25 (When 100HP or less, Temp Rise F & Non-Hazardous)		3/4 Eff.	92.6%
	Opp.	6310ZC3		S.F.1.00 (10:1 C.T., 20:1 V.T., NEMA-MG1 Part31)		NEMA Design	B Torque
Usable at	50Hz 20HP 380V 33.8A 1475rpm S.F.: 1.0 Eff.: 90.6% Code: J						
	50Hz 20HP 400/415V 33.4/33.5A 1480/1480rpm S.F.: 1.0 Eff.: 90.6/90.6% Code: K/L						
CSA Certified for	Model	LATER		Type	PJP	Temp. Code	
		CLASS I, Div. 2, Gr. A, B, C & D	CLASS II, Div. 2 Gr. E, F & G			Amb. 40°C	T3C (160°C)
		CLASS I, Zone 2, Gr. IIA, IIB, & IIC	(Gr. E: Up to 320FR)		(sine wave)	Amb. 55°C	T3A (180°C)
No.	-		Date	-		Weight	360 lb

4M-136024

**MARINE DUTY IEEE45**

Made in Vietnam H4  
Designed By HYUNDAI, Korea



2.36

APPD BY	S.Y.KIM	UNIT	INCH	SUBJECT	CSA Class I, Division2 Severe Duty (HES, 254-326)	DWG SIZE	A4 ( 1:1 )
CHKD BY	I.K.KIM	SCALE	NONE	TITLE	<b>NAMEPLATE DRAWING</b>		
CHKD BY	R.G.KIM	PROJEC'N	3rd Angle				
DSND BY	S.H.LEE	DATE	2024.06.07				
				REF. NO	<b>4M-136024</b>	Sheet No.	of
				DWG NO	<b>NP-HES25-18-284T</b>	Revision No.	<b>0</b>

Type :	PJP
Full Load Torque :	73.4 lb.ft
Load moment of Inertia (J) :	141.396 lb.ft2
Motor moment of Inertia (J) :	3.940 lb.ft2

18.5kW 25HP	4 P	60 Hz
Speed at Full Load :		1775 RPM
Rated Voltage	575V	460V 230V
Full Load Current	24.5A	30.6A 61.3A

SPEED VS TORQUE & CURRENT CURVE

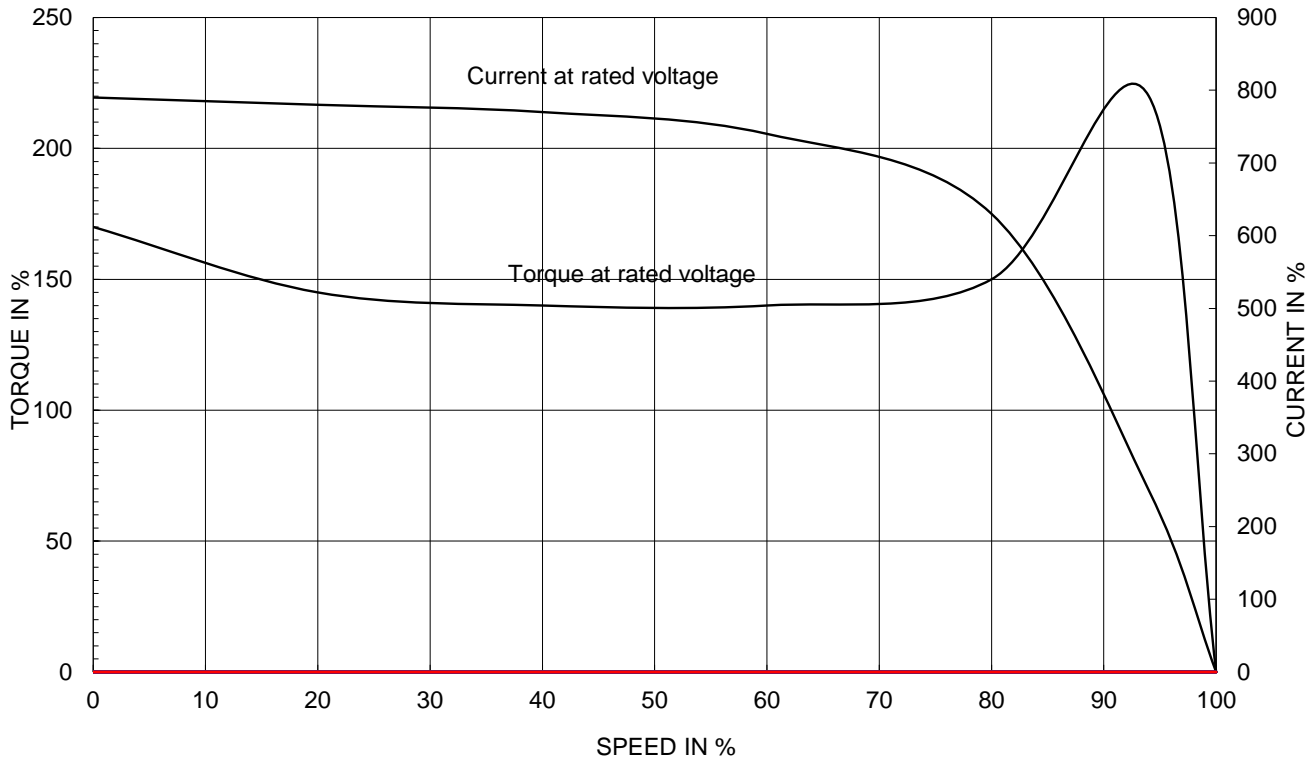

OUTPUT VS EFF., P.F & CURRENT CURVE

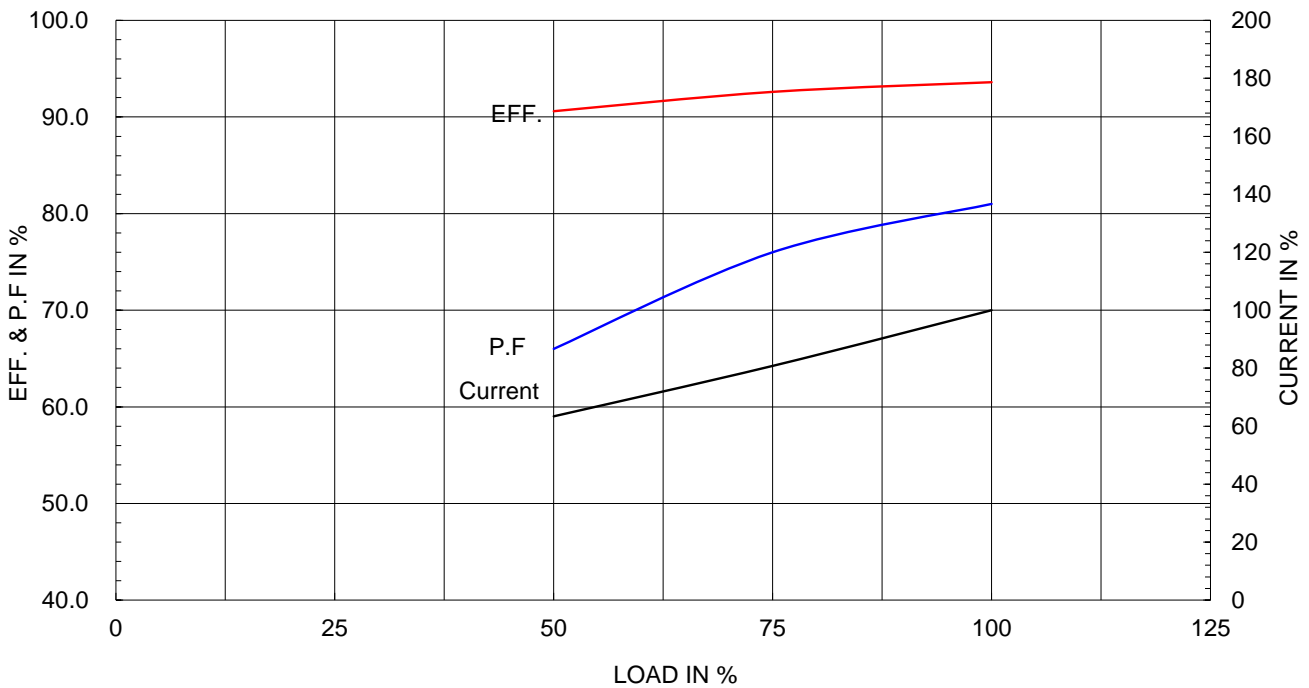

본 도면은 HD현대일렉트릭(주) 재산이며 허가없이 복사할 수 없음 (취급유의)

THIS DRAWING IS PROPRIETARY TO HYUNDAI ELECTRIC. NO PART OF THIS DRAWING MAYBE REPRODUCED WITHOUT THE PERMISSION OF HYUNDAI ELECTRIC.

1		2		3		4			
▽	50S	REV	DATE	CONTENTS		REVD BY	CHKD BY	CHKD BY	APPD BY
▽▽	12.5S								
▽▽▽	3.2S								
▽▽▽▽	0.4S								

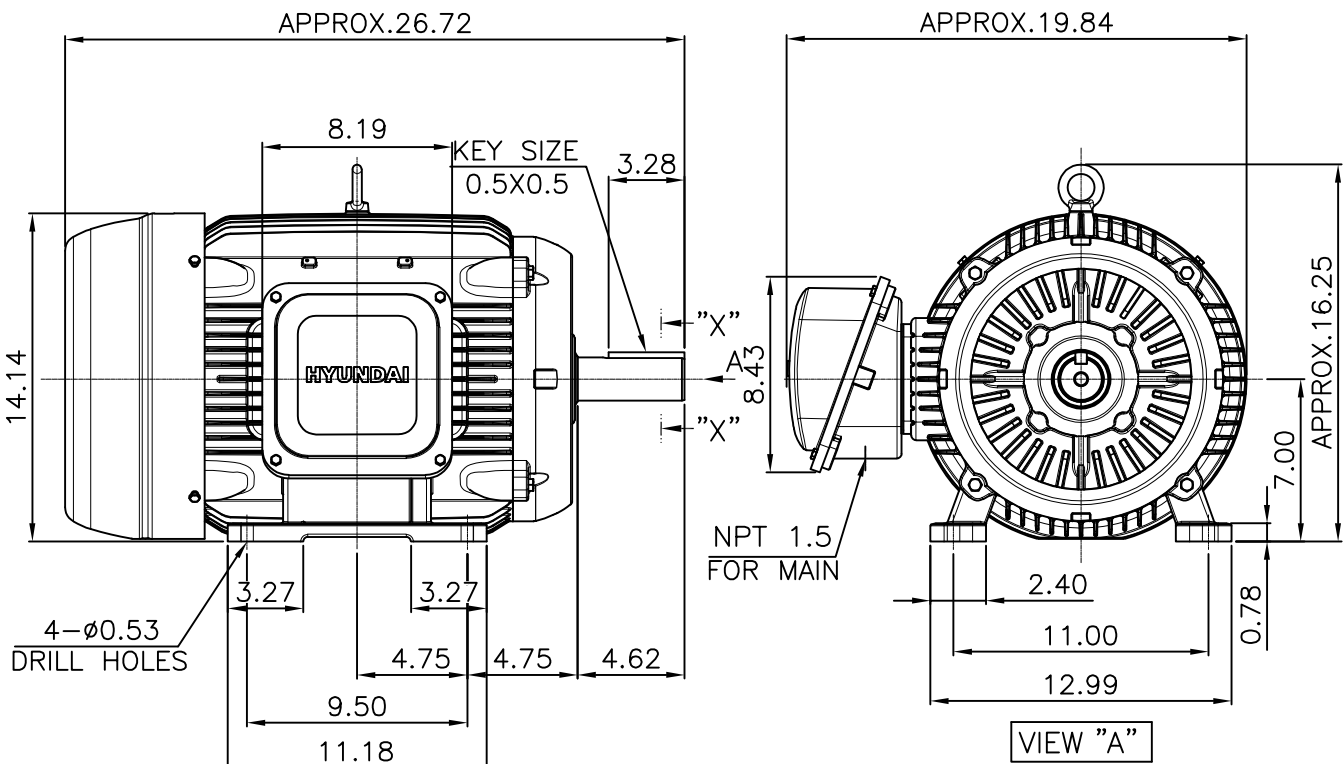

- NOTE**  
[TOLERANCE]
- CENTER HEIGHT : +0.00inch - 0.03inch
  - SHAFT DIAMETER : +0.000inch - 0.001inch
  - KEYWAY DEPTH : +0.000inch - 0.015inch

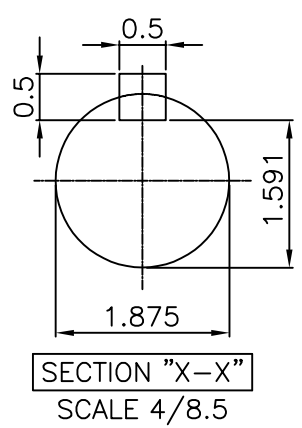

APPD BY	S.Y.KIM	UNIT	mm	SUBJECT	NEMA 284T	DWG SIZE	A4 ( 1:8.5 )
CHKD BY	R.G.KIM	SCALE	1/8.5	TITLE <b>OUTLINE</b>			
CHKD BY		PROJEC'N	3rd Angle				
DSND BY	주유림	DATE	2021-04-28	REF. NO		Sheet No.	of
				DWG NO	LM-T2284B3PLV23	Revision No.	0



Cls. I&II, Div. 2  
IEEE 841



▽	50S
▽▽	12.5S
▽▽▽	3.2S
▽▽▽▽	0.4S

REV	DATE	CONTENTS	REVD BY	CHKD BY	CHKD BY	APPD BY

일반가공공차		일반제관공차	
1-4	±0.1	6-30	±0.5
4-18	±0.2	30-120	±0.8
18-63	±0.3	120-315	±1.2
63-250	±0.5	315-1000	±2.0
250-	±0.8	1000-	±3.0

Q'TY	DESCRIPTION	MATERIAL	DIMENSION	WEIGHT	PART NO.	REMARK	NO.
APPD BY	S.Y.KIM	UNIT	inch(mm)	SUBJECT	FR. 250-280 (CAST IRON)	DWG SIZE	
CHKD BY		SCALE	1/2	TITLE	TERMINAL BOX ASS'Y		
CHKD BY	R.G.KIM	PROJEC'N	3rd Angle	DATE	2023-10-19		
DSND BY	배승희						
REF. NO		Sheet No.	of				
DWG NO	3M-248458	Revision No.	0				

