

Customer :  
Project Name :  
Project No. :  
Revision No. :

# SPECIFICATION for INDUCTION MOTOR



0		For Bidding			
No.	DATE	DESCRIPTION	PREPARED BY	CHECKED BY	APPROVED BY



# AC INDUCTION MOTOR DATA SHEET

Catalog No.	HES20-18-256T	Item No.		Rev. No.	[     ]
Project Name		Project No.		Quantity	sets

GENERAL SPECIFICATION			PERFORMANCE DATA				
Frame Size	256T		Rated Output	15 kW      20 HP			
Type	PJP		Number of Poles	4			
Enclosure(Protection)	Totally Enclosed / IP55		Rotor Type	Squirrel Cage			
Method of Cooling	IC411(FC)		Starting Method*	D.O.L			
Rated Frequency	60 Hz		Rated Voltage	575 V	460 V	230 V	
Number of Phases	3		Current	Full Load	19.9 A	24.8 A	49.7 A
Insulation Class	F			Locked-rotor**	800 %	800 %	800 %
Temp. Rise at full load (by resistance method)			Efficiency				
at 1.0 S.F			80 deg. C				
Motor Location	<input type="checkbox"/> Indoor <input type="checkbox"/> Outdoor		50% Load		90.0 %		
Altitude	Less than 1,000 meter		75% Load		92.0 %		
Relative Humidity	Less than 80 %		100% Load		93.0 %		
Ambient Temp.	40 deg. C (Max.)		Power Factor(p.u)				
Duty Type	Continuous ( S1 )		50% Load		0.665		
Service Factor	1.15		75% Load		0.765		
Mounting	B3		100% Load		0.815		
Bearing	Type	Anti-Friction	Speed at Full Load				1775 r.p.m
	DE/N-DE	6309ZC3 / 6309ZC3	Torque				
	Lubricant	Grease(Polyrex-EM)	Full Load		59.5 lb.ft		
External Thrust	Not applicable		Locked-rotor**		200 %		
Coupling Method	<input checked="" type="checkbox"/> Direct <input type="checkbox"/> V-belt		Breakdown**		240 %		
Shaft Extension	Single		Moment of Inertia (J)				
Terminal Box	Main	Cast Iron	Load(Max.)		122.210 lb.ft2		
	Aux.	No	Motor		2.635 lb.ft2		
Location	Refer to Outline Drawing		Sound Pressure Level (No-load & mean value at 1m from motor)				
			70 dB(A)				
Application			Vibration				3.8 mm/sec (peak)
Area classification	Hazardous		Permissible number of consecutive starts		Cold      3 times		
Type of Ex-Protection	Class I&II, Division 2				Hot      2 times		
Applicable Standard	NEMA MG1, CSA C390		Paint	Munsell No.	4.0PB5.4/5.5(VL-451)		

ACCESSORIES

SUBMITTAL DRAWING		
Outline Dimension Drawing	Motor Weight(Approx.)	
B3	LM-T2256B3PLV23	290 lb.

SPARE PARTS

REMARK				
1. Premium efficiency according to NEMA MG1 2. Inverter Duty @ 1.0 Service Factor & F Temperature rise -. 10:1 VT (20:1 VT at 50% load) -. 10:1 CT -. CHP up to 1.5 times base speed, NEMA MG1 Part31 3. CSA Certification -. Class I, Division 2, Group A, B, C & D -. Class II, Division 2 Group E, F & G (Group E : up to 320Fr.) 4. Service Factor 1.15 and Temperature rise B are applicable under the condition of sine wave power. 5. Service Factor 1.25 is applicable to motors of 100HP or less with temperature rise F & Non-Hazardous.				
Date	DSND	CHKD	CHKD	APPD
2024-07-13	S.H. Lee	I.K. Kim	R.G. Kim	S.W. Kim

[Note] Others not mentioned in this data sheet shall be in accordance with maker standard.  
 Above technical data are only design values and shall be guaranteed with tolerance of applicable standard.  
 Inspection and performance test shall be done according to maker standard, if not mentioned.  
 \* In case of Inverter-Fed Motor, performance data is based on sine wave tests. It may be different from test data of Inverter combined motor.  
 \*\* Data is based on rated voltage & frequency and is expressed as a percentage of full-load value.

1	2	3	4
REV	DATE	CONTENTS	REVD BY

4.72

**CROWN TRITON G2**

Premium Efficiency AC 3 Phase Motor







20HP	4P	230/460V	Cat. No.	HES20-18-256T			
Model	HLS256SR23		INS. Class	F	HD-F1	Amps	49.7/24.8
Type	HLS	Duty	CONT	Code	J	Amb.	40°C
Frame	256T	Encl.	TEFC	S.F.	1.15	RPM	1775
Bearing	Drive	6309ZC3		S.F.1.25 (When 100HP or less, Temp Rise F & Non-Hazardous)		3/4 Eff.	92%
	Opp.	6309ZC3		S.F.1.00 (10:1 C.T., 20:1 V.T., NEMA-MG1 Part31)		NEMA Design	B Torque
Usable at	50Hz 15HP 380V 26.3A 1475rpm S.F.: 1.0 Eff.: 89.8% Code: L						
	50Hz 15HP 400/415V 26.4/27.1A 1480/1480rpm S.F.: 1.0 Eff.: 89.8/89.8% Code: L/L						
CSA Certified for	Model	LATER		Type	PJP	Temp. Code	
		CLASS I, Div. 2, Gr. A, B, C & D	CLASS II, Div. 2 Gr. E, F & G			Amb. 40°C	T3C (160°C)
		CLASS I, Zone 2, Gr. IIA, IIB, & IIC	(Gr. E: Up to 320FR)		(sine wave)	Amb. 55°C	T3A (180°C)
No.	-		Date	-		Weight	290 lb

4M-136024

**MARINE DUTY IEEE45**

Made in Vietnam H4

Designed By HYUNDAI, Korea



2.36

APPD BY	S.Y.KIM	UNIT	INCH	SUBJECT	CSA Class I, Division2 Severe Duty (HES, 254-326)	DWG SIZE
CHKD BY	I.K.KIM	SCALE	NONE			A4 ( 1:1 )
CHKD BY	R.G.KIM	PROJEC'N	3rd Angle	TITLE <b>NAMEPLATE DRAWING</b>		
DSND BY	S.H.LEE	DATE	2024.06.07			
				REF. NO	<b>4M-136024</b>	Sheet No. of
				DWG NO	<b>NP-HES20-18-256T</b>	Revision No. <b>0</b>

Type :	PJP
Full Load Torque :	59.5 lb.ft
Load moment of Inertia (J) :	122.210 lb.ft2
Motor moment of Inertia (J) :	2.635 lb.ft2

15kW	20HP	4 P	60 Hz
Speed at Full Load :			1775 RPM
Rated Voltage	575V	460V	230V
Full Load Current	19.9A	24.8A	49.7A

SPEED VS TORQUE & CURRENT CURVE

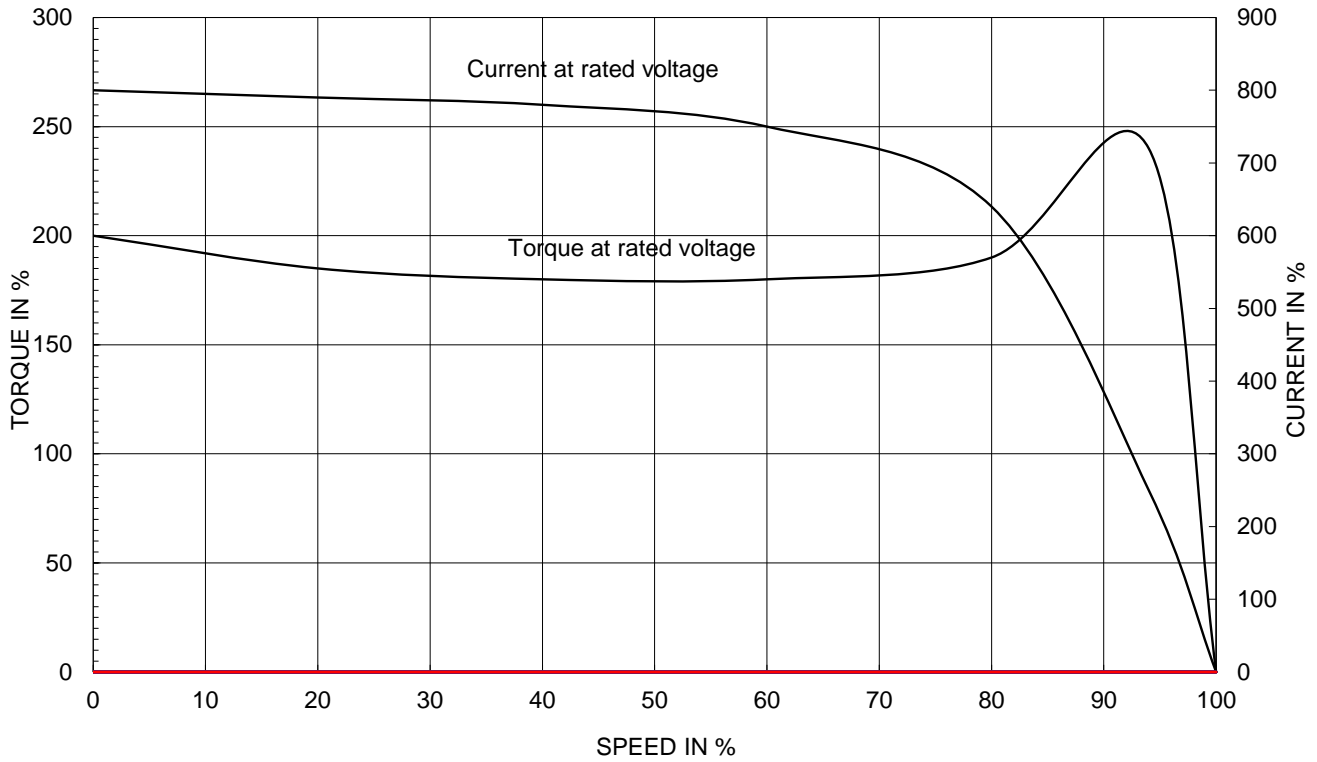

OUTPUT VS EFF., P.F & CURRENT CURVE

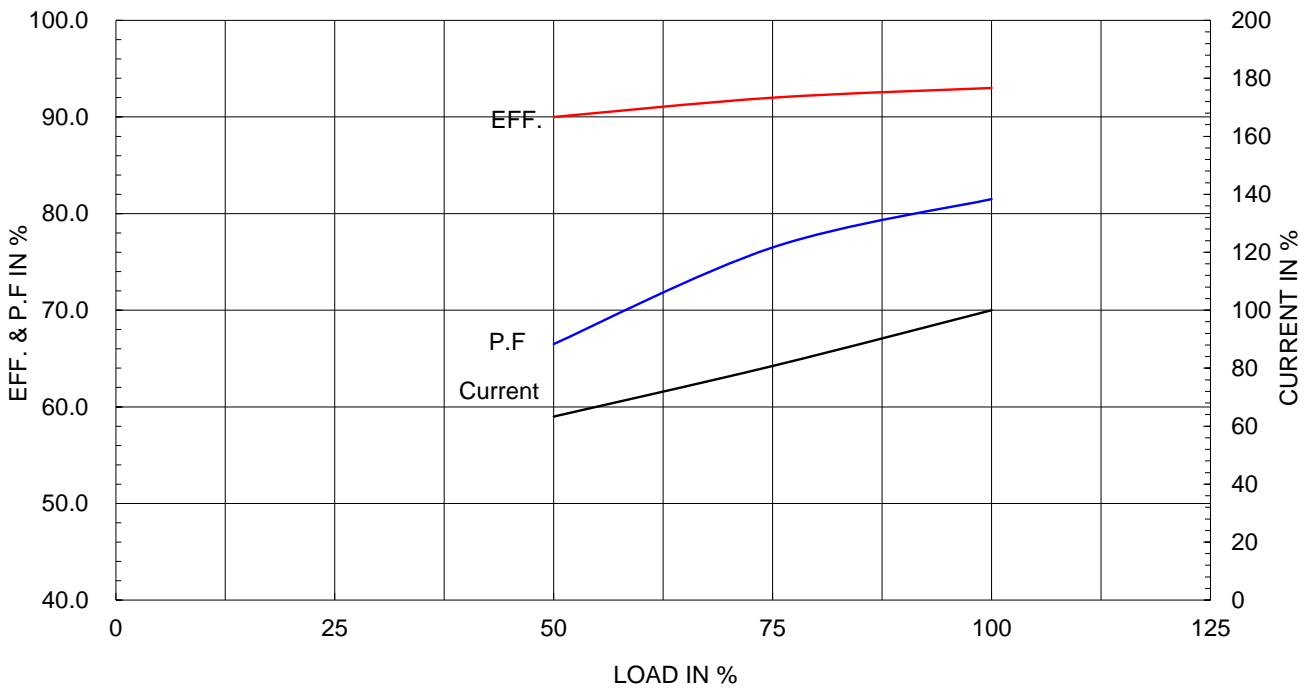

본 도면은 HD현대일렉트릭(주) 재산이며 허가없이 복사할 수 없음 (취급유의)

THIS DRAWING IS PROPRIETARY TO HYUNDAI ELECTRIC. NO PART OF THIS DRAWING MAYBE REPRODUCED WITHOUT THE PERMISSION OF HYUNDAI ELECTRIC.

1		2		3		4			
▽	50S	REV	DATE	CONTENTS		REVD BY	CHKD BY	CHKD BY	APPD BY
▽▽	12.5S								
▽▽▽	3.2S								
▽▽▽▽	0.4S								

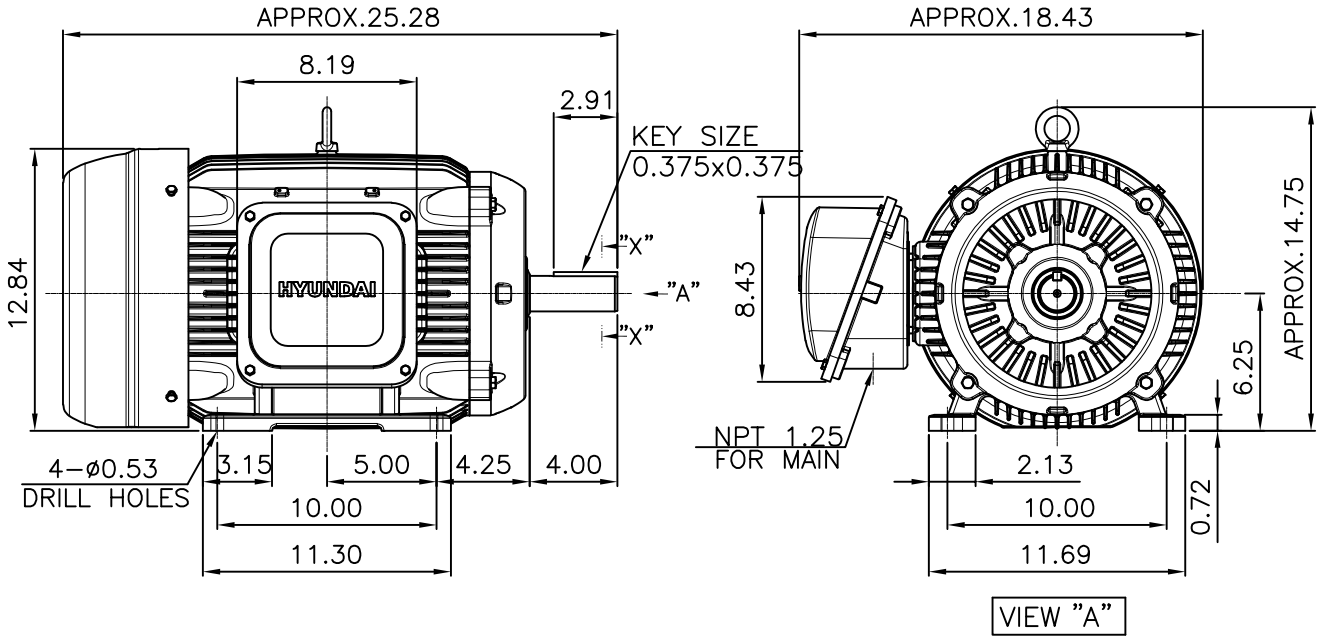

### NOTE

[TOLERANCE]

- CENTER HEIGHT : +0.00inch - 0.03inch
- SHAFT DIAMETER : +0.000inch - 0.001inch
- KEYWAY DEPTH : +0.000inch - 0.015inch

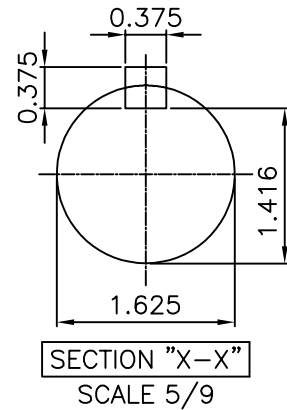

APPD BY	S.Y.KIM	UNIT	mm	SUBJECT	NEMA 256T	DWG SIZE	A4 ( 1:9 )
CHKD BY	R.G.KIM	SCALE	1/9	TITLE <b>OUTLINE</b>			
CHKD BY		PROJEC'N	3rd Angle				
DSND BY	주유림	DATE	2021-04-28				
				REF. NO	.	Sheet No.	of
				DWG NO	LM-T2256B3PLV23	Revision No.	0



Cls. I&II, Div. 2  
IEEE 841



SEC. "A"-"A"

▽	50S
▽▽	12.5S
▽▽▽	3.2S
▽▽▽▽	0.4S

REV	DATE	CONTENTS	REVD BY	CHKD BY	CHKD BY	APPD BY

일반가공공차		일반제관공차	
1-4	±0.1	6-30	±0.5
4-18	±0.2	30-120	±0.8
18-63	±0.3	120-315	±1.2
63-250	±0.5	315-1000	±2.0
250-	±0.8	1000-	±3.0

Q'TY	DESCRIPTION	MATERIAL	DIMENSION	WEIGHT	PART NO.	REMARK	NO.
APPD BY	S.Y.KIM	UNIT	inch(mm)	SUBJECT	FR. 250-280 (CAST IRON)	DWG SIZE	
CHKD BY		SCALE	1/2	TITLE	TERMINAL BOX ASS'Y		
CHKD BY	R.G.KIM	PROJEC'N	3rd Angle	DATE	2023-10-19		
DSND BY	배승희						
REF. NO		Sheet No.	of				
DWG NO	3M-248458	Revision No.	0				

